

Tensar  
Earth Technologies, Inc.

**GENESIS<sup>®</sup>**  
HIGHWAY WALL SYSTEM

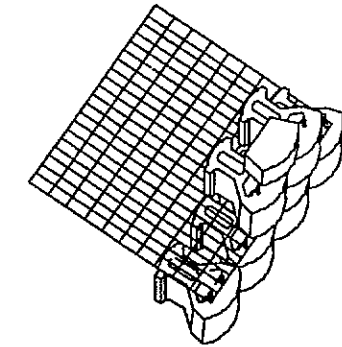

**KEYSTONE<sup>™</sup>**

CONSTRUCTION DRAWINGS  
Prepared For  
STATE OF UTAH  
DEPARTMENT OF TRANSPORTATION  
**I-15 WIDENING**

**UNIVERSITY AVE. INTERCHANGE MODIFICATIONS**

PROVO,

UTAH

UTAH DOT PROJECT No. \*IHDP-15-6 (124) 266

INDEX

| SHEET | DESCRIPTION                        |
|-------|------------------------------------|
| 1.    | Title Sheet                        |
| 2.    | Construction Notes                 |
| 3.    | Elevation View Wall R-319C         |
| 4.    | Elevation View Wall R-319C (Cont.) |
| 5.    | Elevation View Wall R-319C (Cont.) |
| 6.    | Elevation View Wall R-319C (Cont.) |
| 7.    | Elevation View Wall R-319A         |
| 8.    | Elevation View Wall R-319B         |
| 9.    | Typical Cross-Sections             |
| 10.   | Typical Details                    |

| PAY ITEM  | UNIT |
|---|------|
| GENESIS GEOGRID RETAINING WALL R-319A LUMP<br>(EST. QTY 323 SQUARE METER)   |      |
| GENESIS GEOGRID RETAINING WALL R-319B LUMP<br>(EST. QTY 102 SQUARE METER)   |      |
| GENESIS GEOGRID RETAINING WALL R-319C LUMP<br>(EST. QTY 1,010 SQUARE METER) |      |

D96803TS.DWG

THIS DESIGN IS BASED UPON SPECIFIC PROPERTIES OF TENSAR PRODUCTS (GEOGRIDS, DRAINAGE COMPOSITES AND EROSION MEDIA), WHICH ARE PROPRIETARY TO THE TENSAR CORPORATION 1210 CITIZENS PARKWAY, MORROW CA, 92060. ANY SUBSTITUTION OF THE SPECIFIED PRODUCTS WILL INVALIDATE THIS DESIGN. THIS DRAWING IS BEING FURNISHED FOR USE ON THIS SPECIFIC PROJECT ONLY. ANY PARTY ACCEPTING THIS DOCUMENT DOES SO IN CONFIDENCE AND AGREES THAT IT SHALL NOT BE DUPLICATED WHOLE OR IN PART, NOR DISCLOSED TO OTHERS, WITHOUT THE CONSENT OF TENSAR EARTH TECHNOLOGIES, INC.

THIS DRAWING, DESIGN NOTES AND ASSOCIATED CALCULATIONS HAVE BEEN PREPARED BY TENSAR EARTH TECHNOLOGIES, INC. FOR PRELIMINARY DESIGN PURPOSES AND SHALL NOT BE USED FOR FINAL DESIGN OR CONSTRUCTION.  
COPYRIGHT 1996, TENSAR EARTH TECHNOLOGIES, INC.

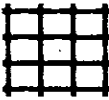
 **TENSAR**  
EARTH TECHNOLOGIES, INC.  
5775-B Glenridge Drive  
Lakeside Center Suite 450  
Atlanta, Georgia 30328  
(404) 250-1290

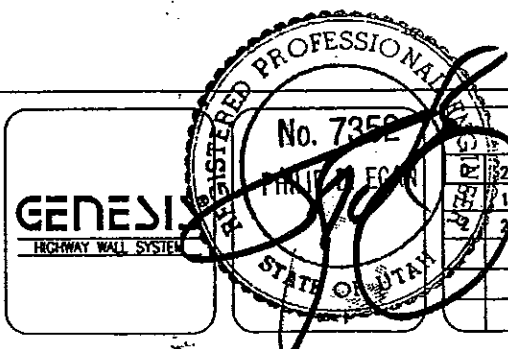

**GENESIS<sup>®</sup>**  
HIGHWAY WALL SYSTEM

REVISIONS \ ISSUE

| NO. | DATE     | DESCRIPTION                   | BY | CHKD |
|-----|----------|-------------------------------|----|------|
| 01  | 02/26/96 | ISSUED FOR BID                |    |      |
| 02  | 12/30/96 | REVISED PER PS&E COMMENTS     |    |      |
| 03  | 2/3/97   | REVISED PER TERRACON COMMENTS |    |      |

Project Number  
D96803  
Date Drawn  
2/26/96  
Scale  
As Shown  
Designed by  
LSB/SEW  
Drawn by  
CVS  
Checked by  
SEW

**I-15 WIDENING**  
UNIVERSITY AVENUE INTERCHANGE MODIFICATIONS  
PROVO, UTAH DOT PROJECT No. \*IHDP-15-6 (124) 266 UTAH  
**TITLE SHEET**  
Sheet Number  
1 of 10

4.02 Design Provisions

DESIGN NOTES FOR GENESIS® HIGHWAY WALL SYSTEM

4.01 Design Parameters

A. Design of the reinforced soil structure is based on the following parameters:

Reinforced Backfill:

| Effective Friction Angle | Effective Cohesion  | Unit Wt.                |
|--------------------------|---------------------|-------------------------|
| 34°                      | 0 kN/m <sup>2</sup> | 19.65 kN/m <sup>3</sup> |

Retained and Foundation Soils:

| Effective Friction Angle | Effective Cohesion  | Unit Wt.                |
|--------------------------|---------------------|-------------------------|
| 30°                      | 0 kN/m <sup>2</sup> | 19.65 kN/m <sup>3</sup> |

- B. Internal Stability:
  - Minimum Factor of Safety for Uncertainties = 1.5
  - Minimum Factor of Safety for Geogrid Pullout = 1.5
  - Percent Coverage of Geogrid = 100%
  - Geogrid/Soil Interaction Coefficient = 1.0
- C. External Stability:
  - Minimum Factor of Safety Against Base Sliding = 1.5
  - Minimum Factor of Safety Against Overturning = 2.0
- D. Global Stability:
  - Global Stability is the responsibility of the Utah Department of Transportation or designated representative. Tensar Earth Technologies, Inc. accepts no liability or responsibility for global stability.
- E. Uniform Surcharge (Live Load - Traffic) = 11.97 kN/m<sup>2</sup>
- F. Hydrostatic Loading = None
- G. Maximum Applied Bearing Pressure = 187 kN/m<sup>2</sup>
- H. Seismic Design Criteria (Walls A, B, & C) = 0.3g (50-yr design)
- Walls A & C = 0.7g (250-yr design)
- FS > 1.0 for 250-yr design

- A. The design soil parameters, foundation conditions, groundwater conditions, and loadings as stated in Section 4.01 must be verified by the owner or owner's representative. A written copy of the report verifying the design parameters must be submitted to Tensar Earth Technologies, Inc. prior to construction.
- B. The elevation views presented herein are based on drawings, dated 11/95, Project No. \*IHDP-15-6(124)266, provided by the Utah Department of Transportation. The elevation views must be verified by the owner or owner's representative prior to construction.
- C. Tensar Earth Technologies, Inc. assumes no liability for interpretation or verification of subsurface conditions, suitability of soil design parameters and interpretations of subsurface groundwater conditions.
- D. The owner or owner's representative is responsible for reviewing and verifying that the actual site conditions are as described in Section 4.01 prior to and during construction. The owner or owner's representative shall be on-site to assure the provisions in the construction notes are followed.
- E. If any rock formation and/or groundwater are encountered during construction, immediately contact Tensar Earth Technologies, Inc. at 404-250-1290 and the owner or owner's representative.
- F. Any revisions to design parameters stated in Section 4.01 or structure geometry shall require design modifications prior to proceeding with construction.
- G. This design is only valid for the proposed GENESIS wall in the plans prepared for the Utah Department of Transportation, I-15 Widening/University Avenue Interchange Modifications Project, Project No. \*IHDP-15-6(124)266.
- H. Tensar Earth Technologies, Inc. accepts no liability or responsibility for global stability, rapid drawdown conditions, flood conditions.
- I. Differential settlement exceeding 1% along the length of the wall face, or 1-meter per 100-meters, and its effects on the GENESIS Highway Wall System shall be the responsibility of the owner or owner's representative.
- J. The GENESIS Highway Wall system has been designed on the assumption that the reinforced backfill material shall be free of subsurface drainage of water (seepage). Permanent subsurface water (seepage) collection and diversion is the responsibility of the owner or owner's representative.
- K. The engineering, design, analysis, detailing and mitigation of both surface water and seepage of groundwater shall be the responsibility of the owner or owner's representative.

ISSUE DATE: 2/27/97

D96803CHLWNG

THIS DESIGN IS BASED UPON SPECIFIC PROPERTIES OF TENSAR PRODUCTS (GEOGRIDS, DRAINAGE COMPOSITES AND EROSION MEDIA), WHICH ARE PROPRIETARY TO THE TENSAR CORPORATION 12110 CITIZENS PARKWAY, MORROW, GA, 30260. ANY SUBSTITUTION OF THE SPECIFIED PRODUCTS WILL INVALIDATE THIS DESIGN. THIS DRAWING IS BEING FURNISHED FOR USE ON THIS SPECIFIC PROJECT ONLY. ANY PARTY ACCEPTING THIS DOCUMENT DOES SO IN CONFIDENCE AND AGREES THAT IT SHALL NOT BE DUPLICATED WHOLE OR IN PART, NOR DISCLOSED TO OTHERS, WITHOUT THE CONSENT OF TENSAR EARTH TECHNOLOGIES, INC.

THIS DRAWING, DESIGN NOTES AND ASSOCIATED CALCULATIONS HAVE BEEN PREPARED BY TENSAR EARTH TECHNOLOGIES, INC. FOR PRELIMINARY DESIGN PURPOSES AND SHALL NOT BE USED FOR FINAL DESIGN OR CONSTRUCTION.

COPYRIGHT 1996, TENSAR EARTH TECHNOLOGIES, INC.

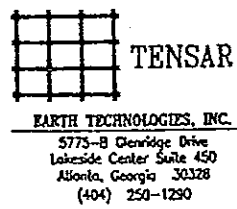

**TENSAR**  
EARTH TECHNOLOGIES, INC.  
5775-B Cleveland Drive  
Lakeside Center Suite 450  
Atlanta, Georgia 30328  
(404) 250-1290

**GENESIS**  
HIGHWAY WALL SYSTEM

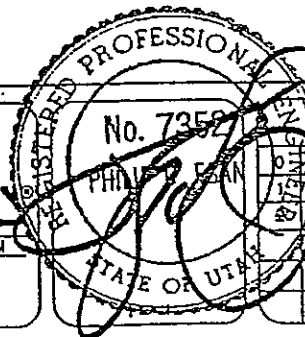

REVISIONS \ ISSUE

| NO. | DATE    | DESCRIPTION                   | BY  |
|-----|---------|-------------------------------|-----|
| 01  | 2/26/96 | ISSUED FOR BID                |     |
| 1   | 2/30/96 | REVISED PER PS&E COMMENTS     |     |
| 2   | 2/3/97  | REVISED PER TERRACON COMMENTS | SEA |

|                          |
|--------------------------|
| Project Number<br>D96803 |
| Date Drawn<br>2/26/96    |
| Scale<br>As Shown        |
| Designed by<br>LSB/SEW   |
| Drawn by<br>CYS          |
| Checked by<br>SEA        |

**I-15 WIDENING**  
UNIVERSITY AVENUE INTERCHANGE MODIFICATIONS  
UTAH DOT PROJECT No. \*IHDP-15-6 (124) 266

PROVO, UTAH

**CONSTRUCTION NOTES**

Sheet Number  
2 of 10

STA. 0+000.00  
 STA. 17+116.04  
 Q. UNIVERSITY AVE.  
 BEGIN WALL  
 STA. 0+002.28  
 STA. 0+003.00  
 STA. 0+004.58  
 STA. 0+005.28  
 STA. 0+006.16  
 STA. 0+009.15

STA. 0+050.00  
 STA. 0+053.50  
 STA. 0+058.29

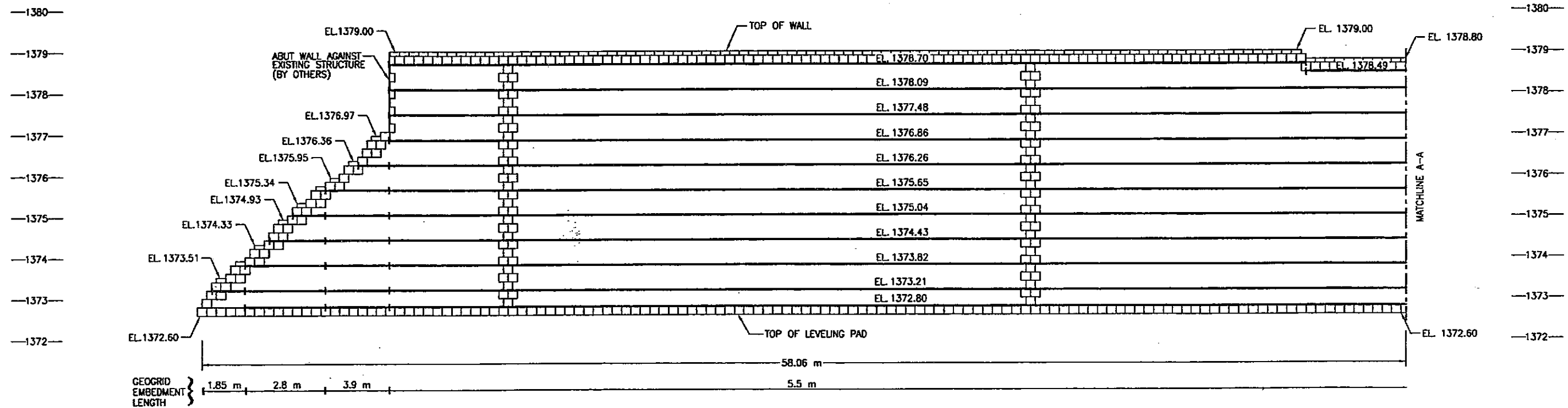

FRONT FACE ELEVATION VIEW

**LEGEND**  
 □ KEYSTONE MINI CAP UNIT  
 □ KEYSTONE COMPAC BLOCK UNIT  
 - - - - - PROPOSED GRADE  
 - - - - - CHANGE IN EMBEDMENT LENGTH OR GEOGRID TERMINATION  
 ——— TENSAR GEOGRID  
 EL. XXXX.XX APPROX. GEOGRID ELEVATION

HORIZONTAL 5 = 1 : 10  
 VERTICAL 2.5 = 1 : 5

D96803W1.DWG

THIS DESIGN IS BASED UPON SPECIFIC PROPERTIES OF TENSAR PRODUCTS (GEOGRIDS, DRAINAGE COMPOSITES AND EROSION MEDIA), WHICH ARE PROPRIETARY TO THE TENSAR CORPORATION 1210 CITIZENS PARKWAY, MORROW CA, 94553. ANY SUBSTITUTION OF THE SPECIFIED PRODUCTS WILL INVALIDATE THIS DESIGN. THIS DRAWING IS BEING FURNISHED FOR USE ON THIS SPECIFIC PROJECT ONLY. ANY PARTY ACCEPTING THIS DOCUMENT DOES SO IN CONFIDENCE AND AGREES THAT IT SHALL NOT BE DUPLICATED WHOLE OR IN PART, NOR DISCLOSED TO OTHERS, WITHOUT THE CONSENT OF TENSAR EARTH TECHNOLOGIES, INC.

THIS DRAWING, DESIGN NOTES AND ASSOCIATED CALCULATIONS HAVE BEEN PREPARED BY TENSAR EARTH TECHNOLOGIES, INC. FOR PRELIMINARY DESIGN PURPOSES AND SHALL NOT BE USED FOR FINAL DESIGN OR CONSTRUCTION.

COPYRIGHT 1996, TENSAR EARTH TECHNOLOGIES, INC.



**TENSAR**  
 EARTH TECHNOLOGIES, INC.  
 5775-B Glenridge Drive  
 Lakeside Center, Suite 450  
 Atlanta, Georgia 30328  
 (404) 250-1290



HIGHWAY WALL SYSTEM

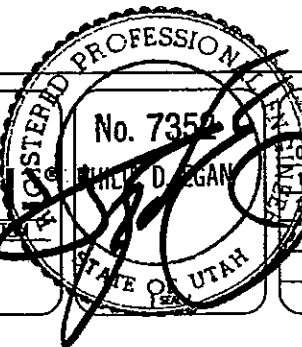

REVISIONS \ ISSUE

| NO. | DATE     | DESCRIPTION                   |
|-----|----------|-------------------------------|
| 1   | 2/26/96  | ISSUED FOR BID                |
| 2   | 12/30/96 | REVISED PER PS&E COMMENTS     |
| 3   | 2/3/97   | REVISED PER TERRACON COMMENTS |

Project Number  
 D96803  
 Date Drawn  
 2/26/96  
 Scale  
 As Shown  
 Designed by  
 LSB/SEW  
 Drawn by  
 CVS  
 Checked by  
 SPW

**I-15 WIDENING**  
 UNIVERSITY AVENUE INTERCHANGE MODIFICATIONS  
 UTAH DOT PROJECT No. \*IHDP-15-6 (124) 266  
 PROVO, UTAH  
**ELEVATION VIEW**  
**MSE RETAINING WALL R-319C**  
 Sheet Number  
**3 of 10**

STA. 0+000.00  
 STA. 17+116.04  
 Q UNIVERSITY AVE.  
 BEGIN WALL  
 STA. 0+002.28  
 STA. 0+003.00  
 STA. 0+004.58  
 STA. 0+005.26  
 STA. 0+006.16  
 STA. 0+009.15

STA. 0+050.00  
 STA. 0+053.50  
 STA. 0+058.29

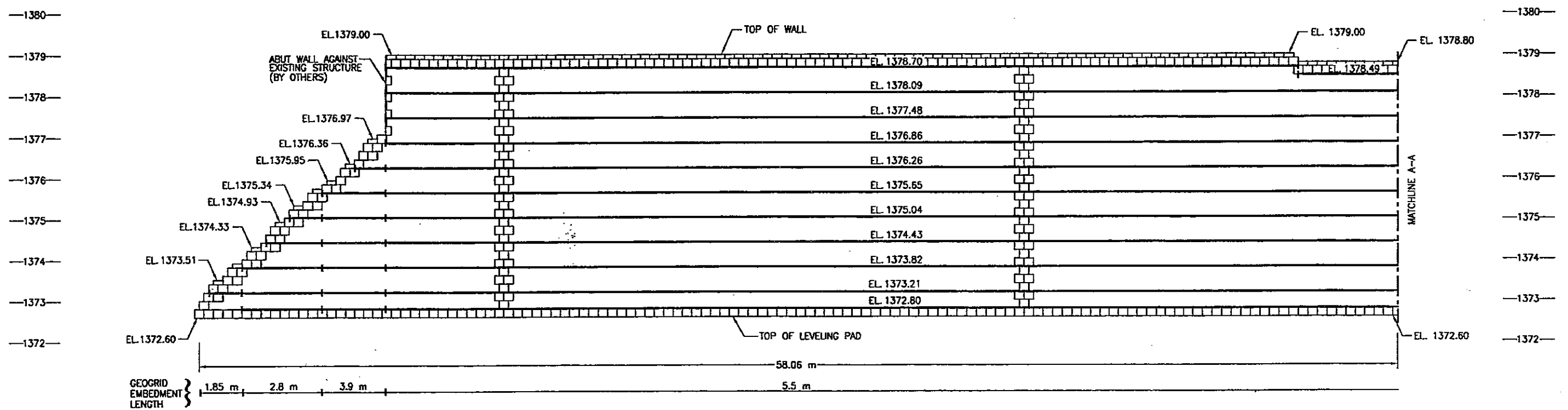

FRONT FACE ELEVATION VIEW

**LEGEND**

- KEYSTONE MINI CAP UNIT
- KEYSTONE COMPAC BLOCK UNIT
- PROPOSED GRADE
- - - - - CHANGE IN EMBEDMENT LENGTH OR GEOGRID TERMINATION
- TENSAR GEOGRID
- EL. XXXX.XX APPROX. GEOGRID ELEVATION

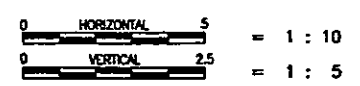

D96803W1.DWG

THIS DESIGN IS BASED UPON SPECIFIC PROPERTIES OF TENSAR PRODUCTS (GEOGRIDS, DRAINAGE COMPOSITES AND EROSION MEDIA), WHICH ARE PROPRIETARY TO THE TENSAR CORPORATION 1210 CITIZENS PARKWAY, MORROW CA 92060. ANY SUBSTITUTION OF THE SPECIFIED PRODUCTS WILL INVALIDATE THIS DESIGN. THIS DRAWING IS BEING FURNISHED FOR USE ON THIS SPECIFIC PROJECT ONLY. ANY PARTY ACCEPTING THIS DOCUMENT DOES SO IN CONFIDENCE AND AGREES THAT IT SHALL NOT BE DUPLICATED WHOLE OR IN PART, NOR DISCLOSED TO OTHERS, WITHOUT THE CONSENT OF TENSAR EARTH TECHNOLOGIES, INC.

THIS DRAWING, DESIGN NOTES AND ASSOCIATED CALCULATIONS HAVE BEEN PREPARED BY TENSAR EARTH TECHNOLOGIES, INC. FOR PRELIMINARY DESIGN PURPOSES AND SHALL NOT BE USED FOR FINAL DESIGN OR CONSTRUCTION.

COPYRIGHT 1996, TENSAR EARTH TECHNOLOGIES, INC.

**TENSAR**  
 EARTH TECHNOLOGIES, INC.  
 5775-B Glenridge Drive  
 Lakeside Center Suite 450  
 Atlanta, Georgia 30328  
 (404) 250-1290

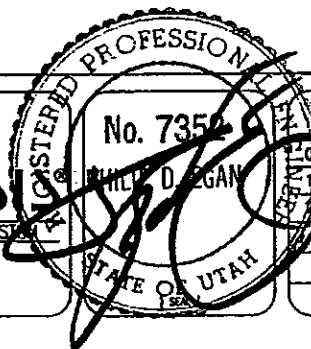
**GENEY**  
 HIGHWAY WALL SYSTEMS

| REVISIONS \ ISSUE |                               |
|-------------------|-------------------------------|
| 2/26/96           | ISSUED FOR BID                |
| 12/30/96          | REVISED PER PS&E COMMENTS     |
| 2/3/97            | REVISED PER TERRACON COMMENTS |

Project Number  
 D96803  
 Date Drawn  
 2/26/96  
 Scale  
 As Shown  
 Designed by  
 LSB/SEW  
 Drawn by  
 CVS  
 Checked by  
 SEW

**I-15 WIDENING**  
 UNIVERSITY AVENUE INTERCHANGE MODIFICATIONS  
 UTAH DOT PROJECT No. \*IHDP-15-6 (124) 266

PROVO, UTAH

**ELEVATION VIEW**  
**MSE RETAINING WALL R-319C**

Sheet Number  
**3 of 10**

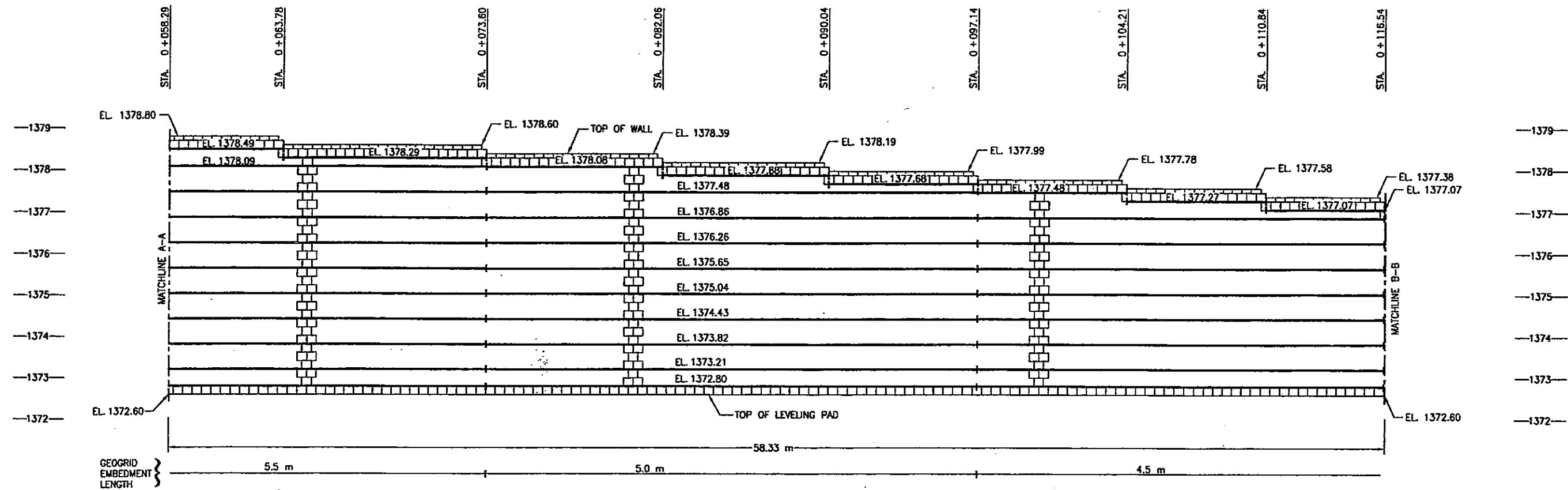

FRONT FACE ELEVATION VIEW

**LEGEND**

- KEystone MINI CAP UNIT
- KEystone COMPAC BLOCK UNIT
- - - - - PROPOSED GRADE
- + - - - CHANGE IN EMBEDMENT LENGTH OR GEOGRID TERMINATION
- TENSAR GEOGRID
- EL. XXXX.XX APPROX. GEOGRID ELEVATION

0 HORIZONTAL 5 = 1 : 10  
 0 VERTICAL 2.5 = 1 : 5

D968031A.DWG

THIS DESIGN IS BASED UPON SPECIFIC PROPERTIES OF TENSAR PRODUCTS (GEOGRIDS, DRAINAGE COMPOSITES AND EROSION MEDIA) WHICH ARE PROPRIETARY TO THE TENSAR CORPORATION 1210 CITIZENS PARKWAY, MORROW GA. 30260. ANY SUBSTITUTION OF THE SPECIFIED PRODUCTS WILL INVALIDATE THIS DESIGN. THIS DRAWING IS BEING FURNISHED FOR USE ON THIS SPECIFIC PROJECT ONLY. ANY PARTY ACCEPTING THIS DOCUMENT DOES SO IN CONFIDENCE AND AGREES THAT IT SHALL NOT BE DUPLICATED WHOLE OR IN PART, NOR DISCLOSED TO OTHERS, WITHOUT THE CONSENT OF TENSAR EARTH TECHNOLOGIES, INC.

THIS DRAWING, DESIGN NOTES AND ASSOCIATED CALCULATIONS HAVE BEEN PREPARED BY TENSAR EARTH TECHNOLOGIES, INC. FOR PRELIMINARY DESIGN PURPOSES AND SHALL NOT BE USED FOR FINAL DESIGN OR CONSTRUCTION.

COPYRIGHT 1996, TENSAR EARTH TECHNOLOGIES, INC.

**TENSAR**  
 EARTH TECHNOLOGIES, INC.  
 5775-B Glenridge Drive  
 Lakeside Center Suite 450  
 Atlanta, Georgia 30328  
 (404) 250-1290

**GENESIS**  
 HIGHWAY WALL SYSTEM

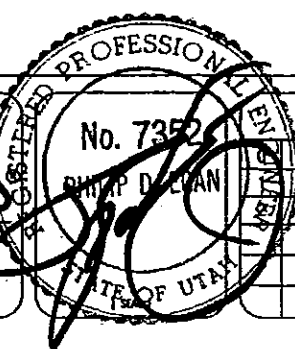

| REVISIONS \ ISSUE |                               |
|-------------------|-------------------------------|
| 2/26/96           | ISSUED FOR BID                |
| 2/30/96           | REVISED PER PS&E COMMENTS     |
| 2/3/97            | REVISED PER TERRACON COMMENTS |

Project Number  
D96803  
 Date Drawn  
2/26/96  
 Scale  
As Shown  
 Designed by  
LSB/SEW  
 Drawn by  
CYS  
 Checked by  
BEW

**I-15 WIDENING**  
 UNIVERSITY AVENUE INTERCHANGE MODIFICATIONS  
 UTAH DOT PROJECT No. \*1HDP-15-6 (124) 266

PROVO, UTAH

**ELEVATION VIEW (CONT.)**  
**MSE RETAINING WALL R-319C**

Sheet Number  
4 of 10

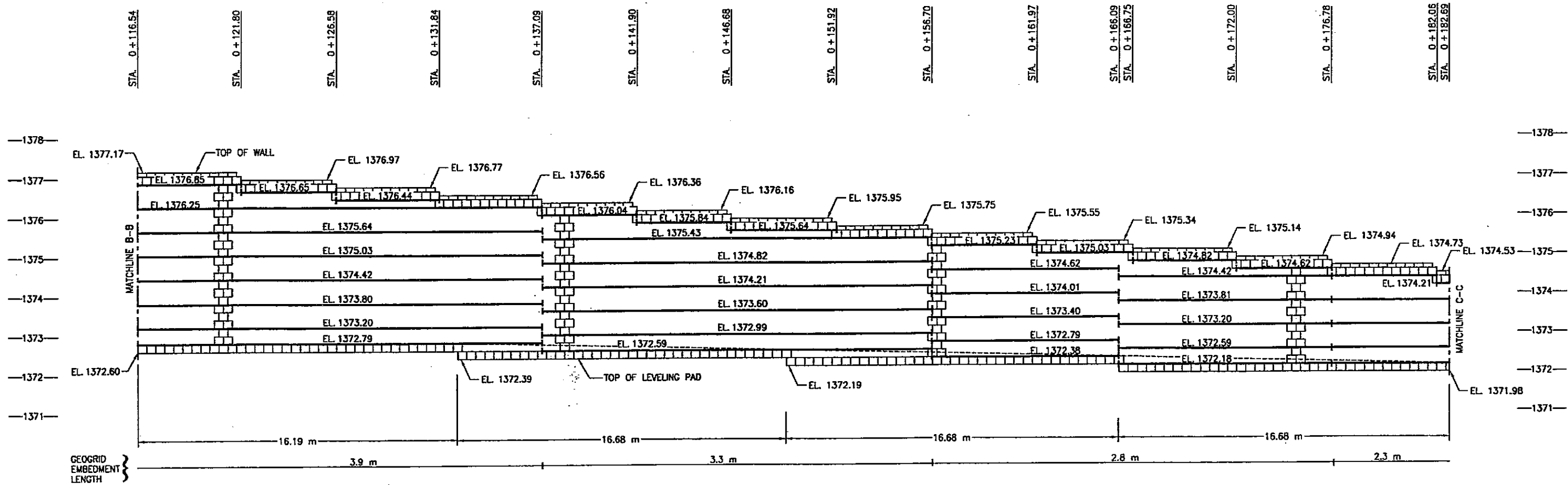

FRONT FACE ELEVATION VIEW

**LEGEND**

- KEYSTONE MINI CAP UNIT
- KEYSTONE COMPAC BLOCK UNIT
- - - - - PROPOSED GRADE
- + - - - CHANGE IN EMBEDMENT LENGTH OR GEOGRID TERMINATION
- TENSAR GEOGRID
- EL. XXXX.XX APPROX. GEOGRID ELEVATION

0 — HORIZONTAL — 5 = 1 : 10  
 0 — VERTICAL — 2.5 = 1 : 5

0968031B.DWG

THIS DESIGN IS BASED UPON SPECIFIC PROPERTIES OF TENSAR PRODUCTS (GEOGRIDS, DRAINAGE COMPOSITES AND EROSION MEDIA), WHICH ARE PROPRIETARY TO THE TENSAR CORPORATION 1210 CITIZENS PARKWAY, MORRISON GA 30260. ANY SUBSTITUTION OF THE SPECIFIED PRODUCTS WILL INVALIDATE THIS DESIGN. THIS DRAWING IS BEING FURNISHED FOR USE ON THIS SPECIFIC PROJECT ONLY. ANY PARTY ACCEPTING THIS DOCUMENT DOES SO IN CONFIDENCE AND AGREES THAT IT SHALL NOT BE DUPLICATED WHOLE OR IN PART, NOR DISCLOSED TO OTHERS, WITHOUT THE CONSENT OF TENSAR EARTH TECHNOLOGIES, INC.

THIS DRAWING, DESIGN NOTES AND ASSOCIATED CALCULATIONS HAVE BEEN PREPARED BY TENSAR EARTH TECHNOLOGIES, INC. FOR PRELIMINARY DESIGN PURPOSES AND SHALL NOT BE USED FOR FINAL DESIGN OR CONSTRUCTION.

COPYRIGHT 1996, TENSAR EARTH TECHNOLOGIES, INC.

**TENSAR**  
 EARTH TECHNOLOGIES, INC.  
 5775-B Glenridge Drive  
 Lakeside Center Suite 450  
 Atlanta, Georgia 30328  
 (404) 250-1290

**GENESEE**  
 HIGHWAY WALL SYSTEM

| REVISIONS \ ISSUE |                               |
|-------------------|-------------------------------|
| 2/26/96           | ISSUED FOR BID                |
| 12/30/96          | REVISED PER PS&E COMMENTS     |
| 2/3/97            | REVISED PER TERRACON COMMENTS |

Project Number  
096803  
 Date Drawn  
2/26/96  
 Scale  
As Shown  
 Designed by  
LSB/SEW  
 Drawn by  
CVS  
 Checked by  
SEW

**I-15 WIDENING**  
 UNIVERSITY AVENUE INTERCHANGE MODIFICATIONS  
 UTAH DOT PROJECT No. \*IHD-15-6 (124) 266

PROVO, UTAH

ELEVATION VIEW (CONT.)  
 MSE RETAINING WALL R-319C

Sheet Number  
5 of 10

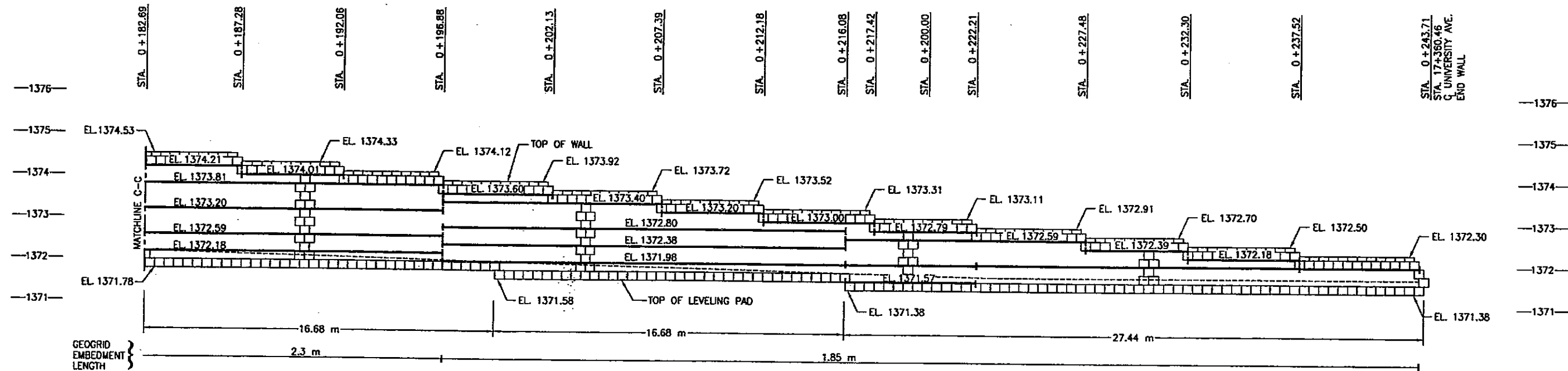

FRONT FACE ELVATION VIEW

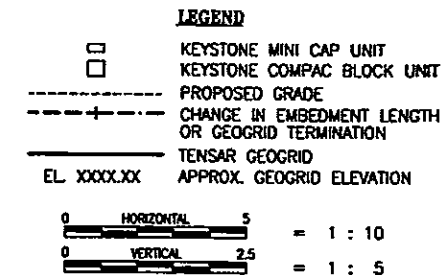

D968031C.DWG

THIS DESIGN IS BASED UPON SPECIFIC PROPERTIES OF TENSAR PRODUCTS (GEOGRIDS, DRAINAGE COMPOSITES AND EROSION MEDIA), WHICH ARE PROPRIETARY TO THE TENSAR CORPORATION 1210 CITIZENS PARKWAY, MORRIS, GA. 30260. ANY SUBSTITUTION OF THE SPECIFIED PRODUCTS WILL INVALIDATE THIS DESIGN. THIS DRAWING IS BEING FURNISHED FOR USE ON THIS SPECIFIC PROJECT ONLY. ANY PARTY ACCEPTING THIS DOCUMENT DOES SO IN CONFIDENCE AND AGREES THAT IT SHALL NOT BE DUPLICATED WHOLE OR IN PART, NOR DISCLOSED TO OTHERS, WITHOUT THE CONSENT OF TENSAR EARTH TECHNOLOGIES, INC.

THIS DRAWING, DESIGN NOTES AND ASSOCIATED CALCULATIONS HAVE BEEN PREPARED BY TENSAR EARTH TECHNOLOGIES, INC. FOR PRELIMINARY DESIGN PURPOSES AND SHALL NOT BE USED FOR FINAL DESIGN OR CONSTRUCTION.

COPYRIGHT 1996, TENSAR EARTH TECHNOLOGIES, INC.

**TENSAR**

EARTH TECHNOLOGIES, INC.

5775-B Glenridge Drive  
Lakeside Center Suite 450  
Atlanta, Georgia 30328  
(404) 250-1290

**GENEY**

REGISTERED PROFESSIONAL ENGINEER

No. 7352

PHILIP J. GENEY

STATE OF UTAH

HIGHWAY WALL SYSTEM

| REVISIONS \ ISSUE |                               |
|-------------------|-------------------------------|
| 2/26/96           | ISSUED FOR BID                |
| 12/30/96          | REVISED PER PS&E COMMENTS     |
| 2/3/97            | REVISED PER TERRACON COMMENTS |

Project Number  
D96803

Date Drawn  
2/26/96

Scale  
As Shown

Designed by  
LSB/SEW

Drawn by  
CVS

Checked by  
SEW

**I-15 WIDENING**

UNIVERSITY AVENUE INTERCHANGE MODIFICATIONS  
UTAH DOT PROJECT No. \*I10P-15-6 (124) 266

PROVO, UTAH

ELEVATION VIEW (CONT.)  
MSE RETAINING WALL R-319C

Sheet Number  
6 of 10

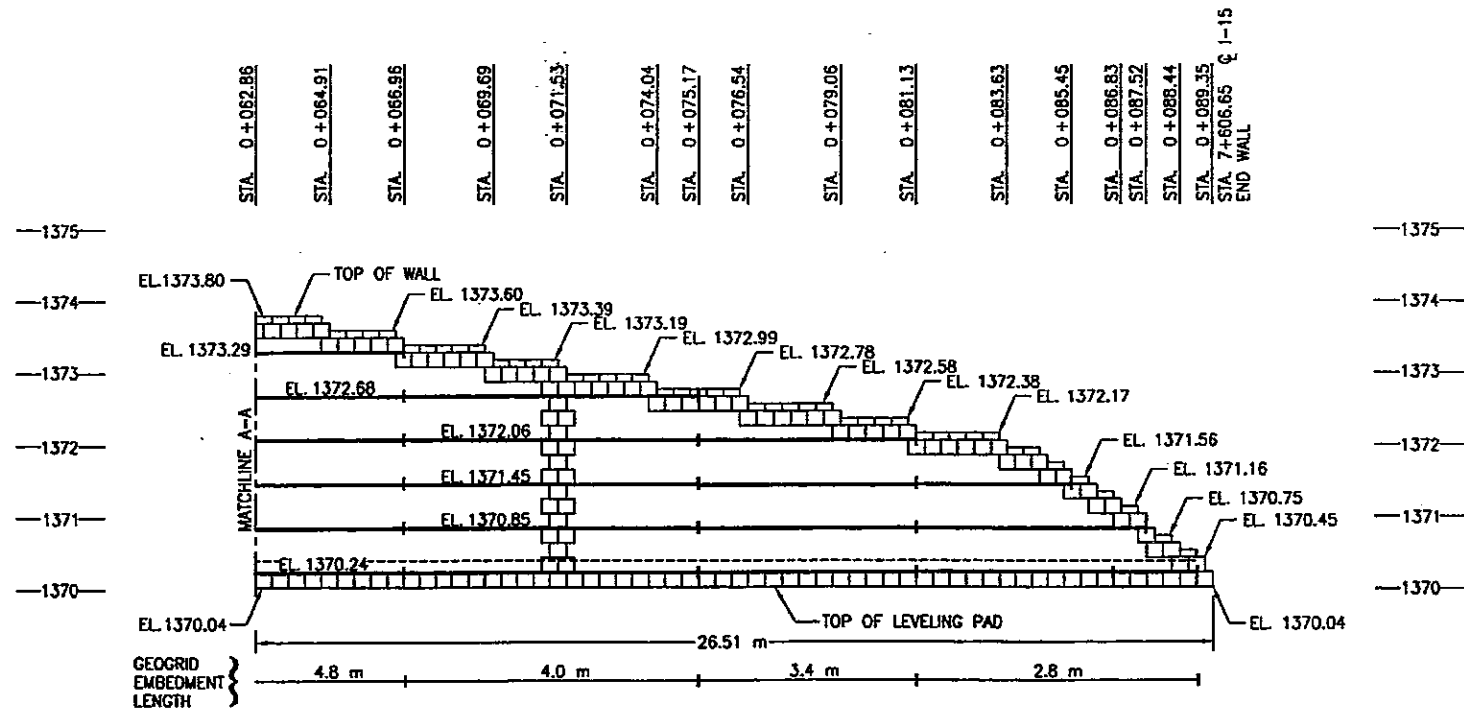
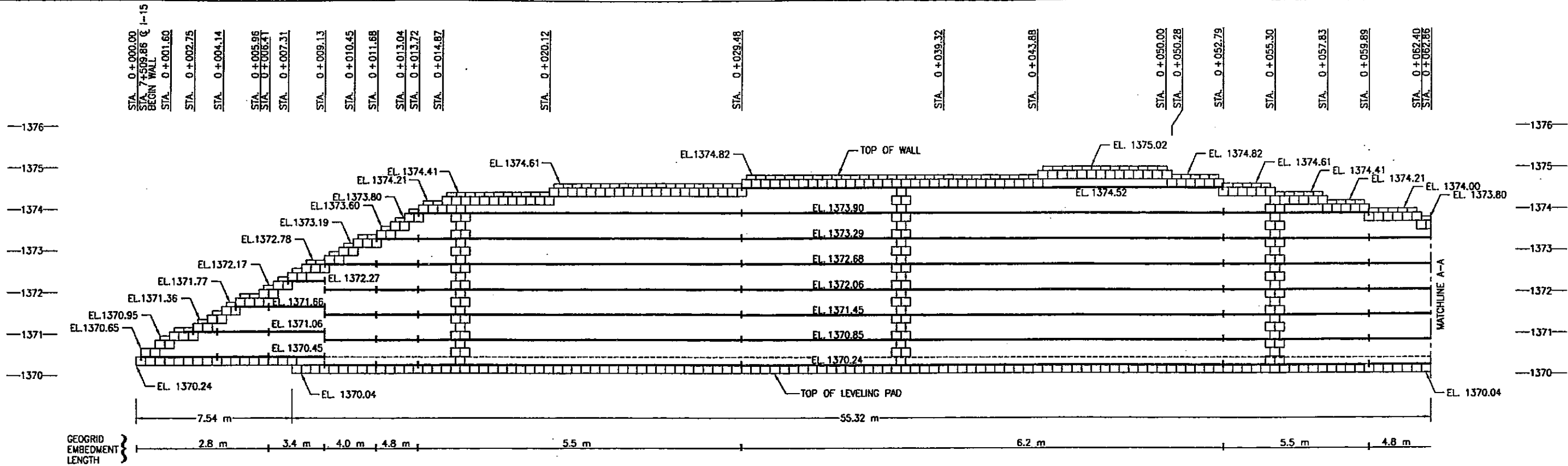

- KEYSTONE MINI CAP UNIT
- KEYSTONE COMPAC BLOCK UNIT
- PROPOSED GRADE
- CHANGE IN EMBEDMENT LENGTH OR GEOGRID TERMINATION
- TENSAR GEOGRID
- APPROX. GEOGRID ELEVATION

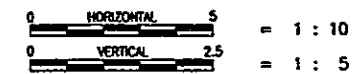

FRONT FACE ELEVATION VIEW

D96802W2.DWG

THIS DESIGN IS BASED UPON SPECIFIC PROPERTIES OF TENSAR PRODUCTS (GEOGRIDS, DRAINAGE COMPOSITES AND EROSION MEDIA), WHICH ARE PROPRIETARY TO THE TENSAR CORPORATION 1210 CITIZENS PARKWAY, MORROW, GA. 30260. ANY SUBSTITUTION OF THE SPECIFIED PRODUCTS WILL INVALIDATE THIS DESIGN. THIS DRAWING IS BEING FURNISHED FOR USE ON THIS SPECIFIC PROJECT ONLY. ANY PARTY ACCEPTING THIS DOCUMENT DOES SO IN CONFIDENCE AND AGREES THAT IT SHALL NOT BE DUPLICATED WHOLE OR IN PART, NOR DISCLOSED TO OTHERS, WITHOUT THE CONSENT OF TENSAR EARTH TECHNOLOGIES, INC.

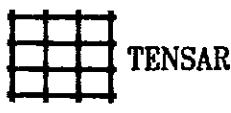

TENSAR  
EARTH TECHNOLOGIES, INC.  
5775-B Glenridge Drive  
Lakeside Center Suite 450  
Atlanta, Georgia 30328  
(404) 250-1290

GENESIS  
HIGHWAY WALL SYSTEM

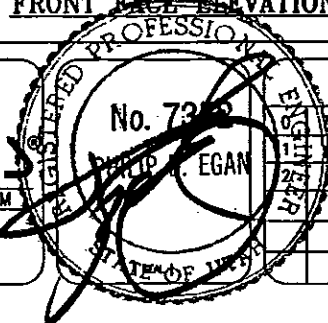

REVISIONS \ ISSUE

| NO. | DATE    | DESCRIPTION                   |
|-----|---------|-------------------------------|
| 1   | 2/26/96 | ISSUED FOR BID                |
| 2   | 2/30/96 | REVISED PER PS&E COMMENTS     |
| 3   | 2/3/97  | REVISED PER TERRACON COMMENTS |

Project Number  
D96803  
Date Drawn  
2/26/96  
Scale  
As Shown  
Designed by  
LSB/SEW  
Drawn by  
CVS  
Checked by  
SEW

I-15 WIDENING  
UNIVERSITY AVENUE INTERCHANGE MODIFICATIONS  
UTAH DOT PROJECT No. \*1HDP-15-6 (124) 266

PROVO, UTAH

ELEVATION VIEW  
MSE RETAINING WALL R-319A

Sheet Number  
7 of 10



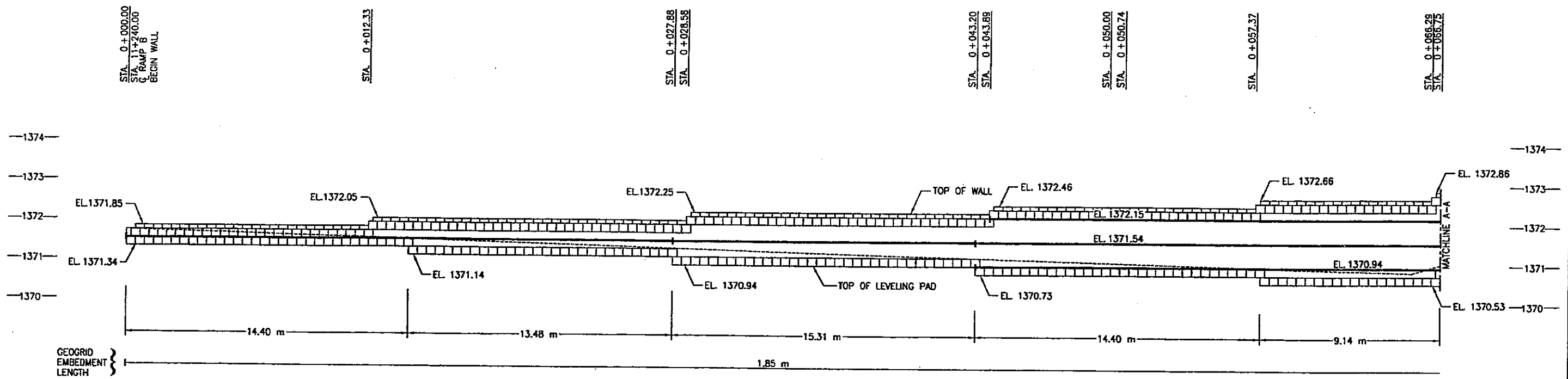

STA 0+066.75  
 STA 0+067.90  
 STA 0+069.70  
 STA 0+070.86  
 STA 0+072.18  
 STA 0+074.92  
 STA 0+076.53  
 STA 0+079.31  
 STA 0+080.22  
 STA 1+320.22  
 RAMP B  
 END WALL

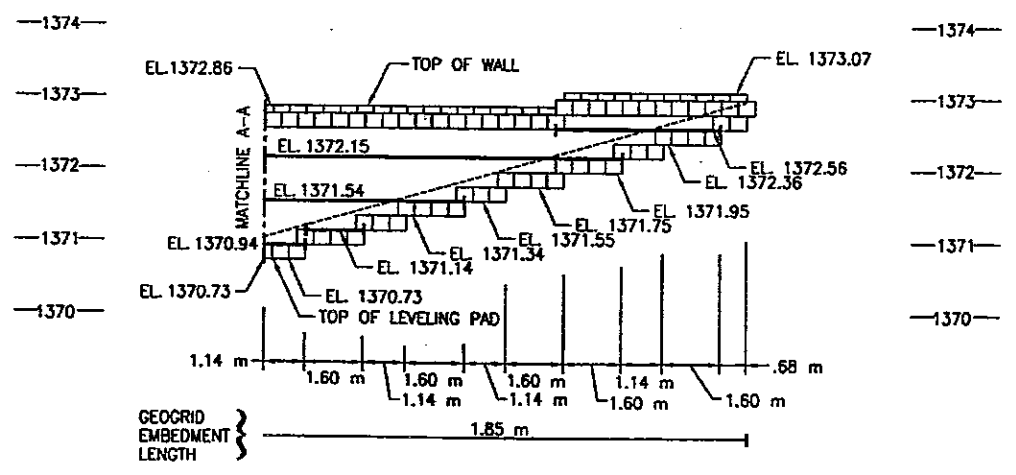

**LEGEND**

- KEYSTONE MINI CAP UNIT
- KEYSTONE COMPAC BLOCK UNIT
- PROPOSED GRADE
- CHANGE IN EMBEDMENT LENGTH OR GEOGRID TERMINATION
- TENSAR GEOGRID
- EL. XXXX.XX APPROX. GEOGRID ELEVATION

0 HORIZONTAL 5 = 1 : 10  
 0 VERTICAL 2.5 = 1 : 5

FRONT FACE ELEVATION VIEW

D96803W3.DWG

THIS DESIGN IS BASED UPON SPECIFIC PROPERTIES OF TENSAR PRODUCTS (GEOGRIDS, DRAINAGE COMPOSITES AND EROSION MEDIA), WHICH ARE PROPRIETARY TO THE TENSAR CORPORATION 1210 CITIZENS PARKWAY, MARIETTA, GA. 30060. ANY SUBSTITUTION OF THE SPECIFIED PRODUCTS WILL INVALIDATE THIS DESIGN. THIS DRAWING IS BEING FURNISHED FOR USE ON THIS SPECIFIC PROJECT ONLY. ANY PARTY ACCEPTING THIS DOCUMENT DOES SO IN CONFIDENCE AND AGREES THAT IT SHALL NOT BE DUPLICATED WHOLE OR IN PART, NOR DISCLOSED TO OTHERS, WITHOUT THE CONSENT OF TENSAR EARTH TECHNOLOGIES, INC.

THIS DRAWING, DESIGN NOTES AND ASSOCIATED CALCULATIONS HAVE BEEN PREPARED BY TENSAR EARTH TECHNOLOGIES, INC. FOR PRELIMINARY DESIGN PURPOSES AND SHALL NOT BE USED FOR FINAL DESIGN OR CONSTRUCTION.

COPYRIGHT 1996, TENSAR EARTH TECHNOLOGIES, INC.

**TENSAR**  
 EARTH TECHNOLOGIES, INC.  
 5775-B Glenridge Drive  
 Lakeside Center Suite 450  
 Atlanta, Georgia 30328  
 (404) 250-1290

**GENEVA**  
 REGISTERED PROFESSIONAL ENGINEER  
 No. 7358  
 STATE OF UTAH

| REVISIONS \ ISSUE |                               |
|-------------------|-------------------------------|
| 2/26/96           | ISSUED FOR BID                |
| 12/30/96          | REVISED PER PS&E COMMENTS     |
| 2/3/97            | REVISED PER TERRACON COMMENTS |

Project Number  
 D96803  
 Date Drawn  
 2/26/96  
 Scale  
 As Shown  
 Designed by  
 LSH/SEW  
 Drawn by  
 CYS  
 Checked by  
 SEW

**I-15 WIDENING**  
 UNIVERSITY AVENUE INTERCHANGE MODIFICATION  
 UTAH DOT PROJECT No. \*1HDP-15-6 (124) 265

PROVO, UTAH

**ELEVATION VIEW**  
**MSE RETAINING WALL R-319B**

Sheet Number  
**8 of 10**

NOTE:  
 CONCRETE GUTTER (NOT INCLUDED IN GENESIS WALL SYSTEM) SHALL EXTEND FOR ENTIRE OF WALL R-319A. DISCHARGE AT END OF WALL SHALL BE DIRECTED AWAY FROM WALL AS SPECIFIED BY SITE ENGINEER.

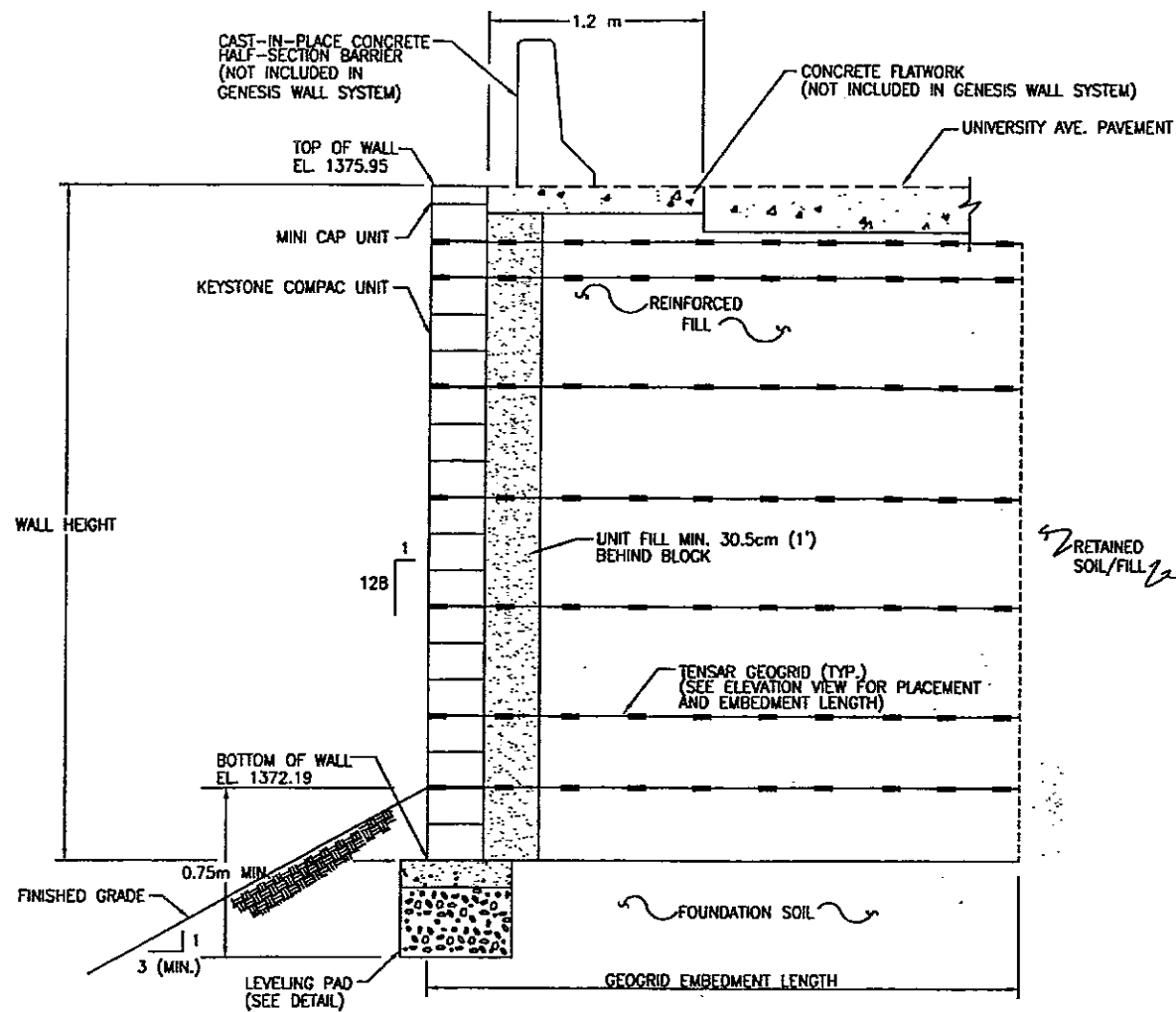

**CROSS-SECTION AT WALL R-319C**  
 STA. 0+150.00 = C STA. 17+266.04

SCALE: 1 : 20

NOTE:  
 CONTRACTOR SHALL REFER TO ELEVATION VIEWS FOR GEOGRID TYPE, ELEVATION AND EMBEDMENT.

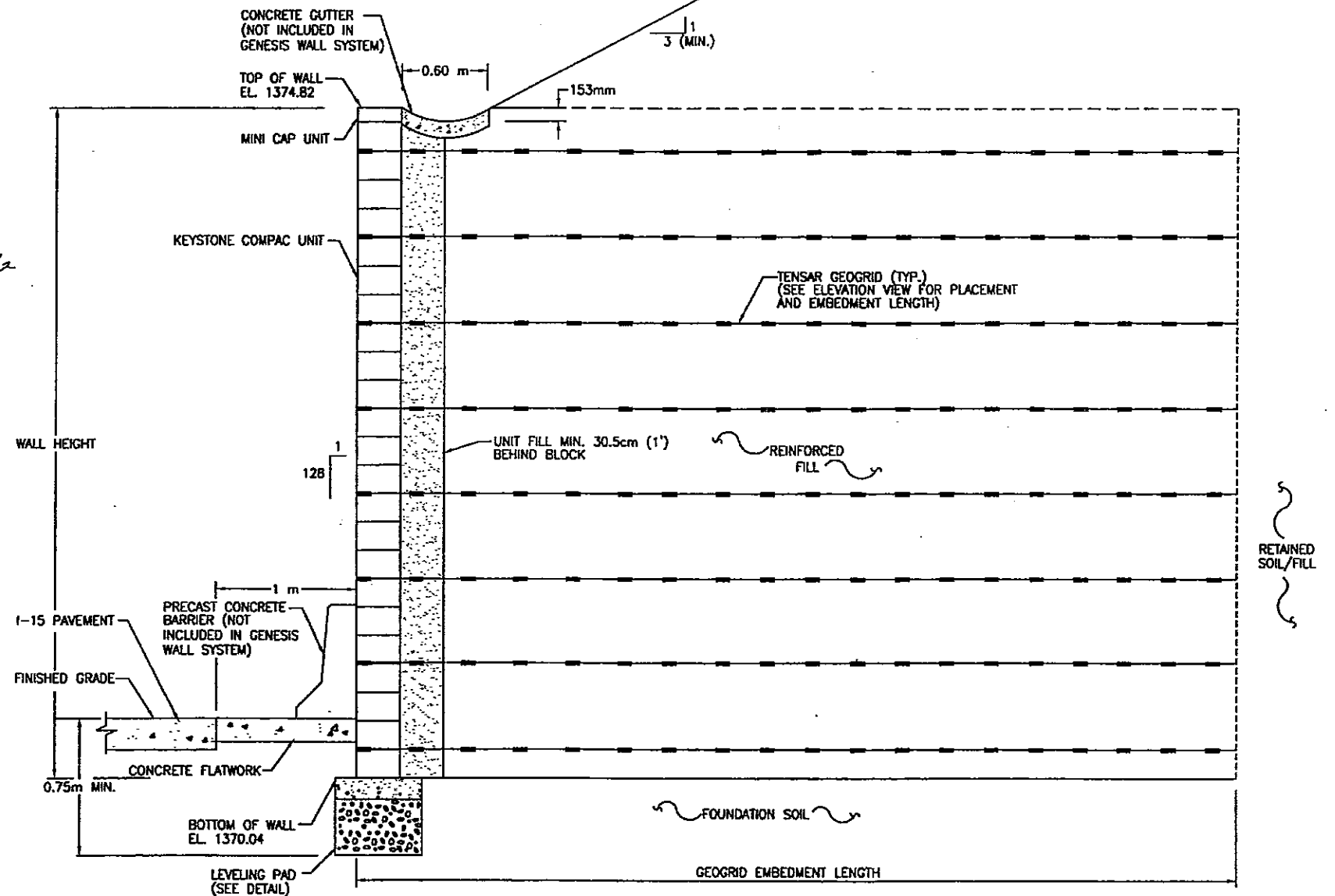

**CROSS-SECTION AT WALL R-319A**  
 STA. 0+030.00 = C STA. 7+539.86

SCALE: 1 : 20

D96803CS.DWG

THIS DESIGN IS BASED UPON SPECIFIC PROPERTIES OF TENSAR PRODUCTS (GEOGRIDS, DRAINAGE COMPOSITES AND EROSION MEDIA), WHICH ARE PROPRIETARY TO THE TENSAR CORPORATION 1210 CITIZENS PARKWAY, MORRIS GA 30260. ANY SUBSTITUTION OF THE SPECIFIED PRODUCTS WILL INVALIDATE THIS DESIGN. THIS DRAWING IS BEING FURNISHED FOR USE ON THIS SPECIFIC PROJECT ONLY. ANY PARTY ACCEPTING THIS DOCUMENT DOES SO IN CONFIDENCE AND AGREES THAT IT SHALL NOT BE DUPLICATED WHOLE OR IN PART, NOR DISCLOSED TO OTHERS, WITHOUT THE CONSENT OF TENSAR EARTH TECHNOLOGIES, INC.

THIS DRAWING, DESIGN NOTES AND ASSOCIATED CALCULATIONS HAVE BEEN PREPARED BY TENSAR EARTH TECHNOLOGIES, INC. FOR PRELIMINARY DESIGN PURPOSES AND SHALL NOT BE USED FOR FINAL DESIGN OR CONSTRUCTION.

COPYRIGHT 1996, TENSAR EARTH TECHNOLOGIES, INC.



**TENSAR**

EARTH TECHNOLOGIES, INC.  
 5775-B Glenridge Drive  
 Lakeside Center Suite 450  
 Atlanta, Georgia 30328  
 (404) 250-1290

**GENESIS**  
 HIGHWAY WALL SYSTEM

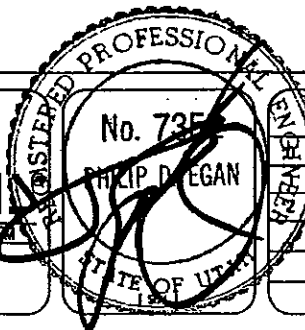

REVISIONS \ ISSUE

| NO. | DATE     | DESCRIPTION                   |
|-----|----------|-------------------------------|
| 1   | 2/26/96  | ISSUED FOR BID                |
| 2   | 12/30/96 | REVISED PER PS&E COMMENTS     |
| 3   | 2/3/97   | REVISED PER TERRACON COMMENTS |

Project Number  
 D96803  
 Date Drawn  
 2/26/96  
 Scale  
 As Shown  
 Designed by  
 LSB/SEW  
 Drawn by  
 CVS/BBC  
 Checked by  
 SEW

**I-15 WIDENING**  
 UNIVERSITY AVENUE INTERCHANGE MODIFICATIONS  
 UTAH DOT PROJECT No. \*IHD-15-6 (124) 266

PROVO,

UTAH

TYPICAL  
 CROSS-SECTIONS

Sheet Number  
 9 of 10

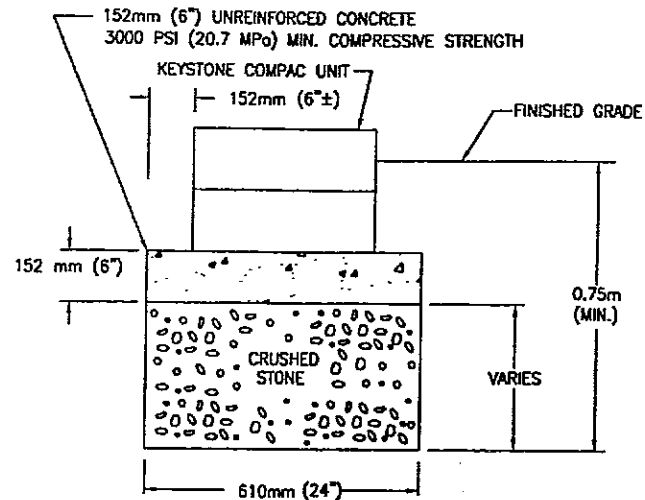

**LEVELING PAD DETAIL**  
NOT TO SCALE

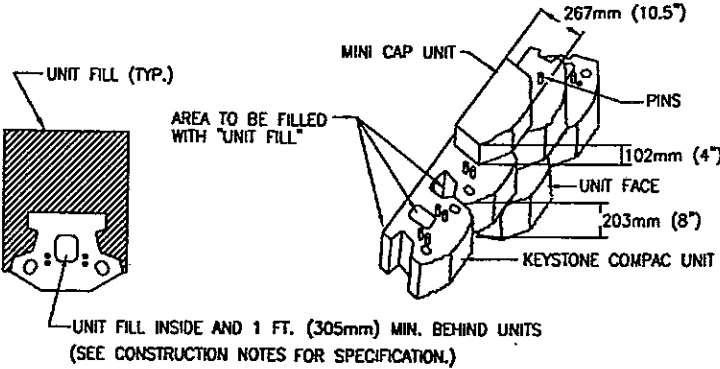

**KEYSTONE COMPAC UNIT DETAIL**  
NOT TO SCALE

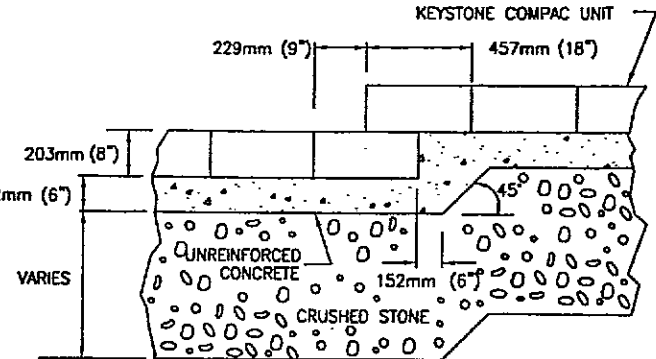

**TYPICAL LEVELING PAD STEP DETAIL**  
NOT TO SCALE

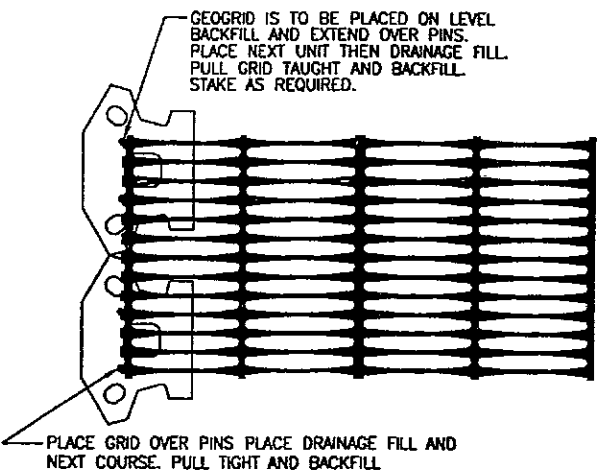
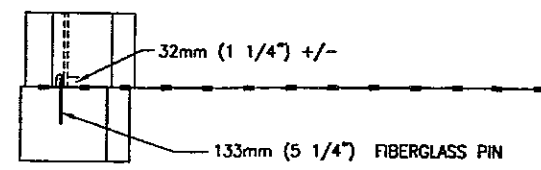

**KEYSTONE COMPAC & GRID CONNECTION DETAIL**  
NOT TO SCALE

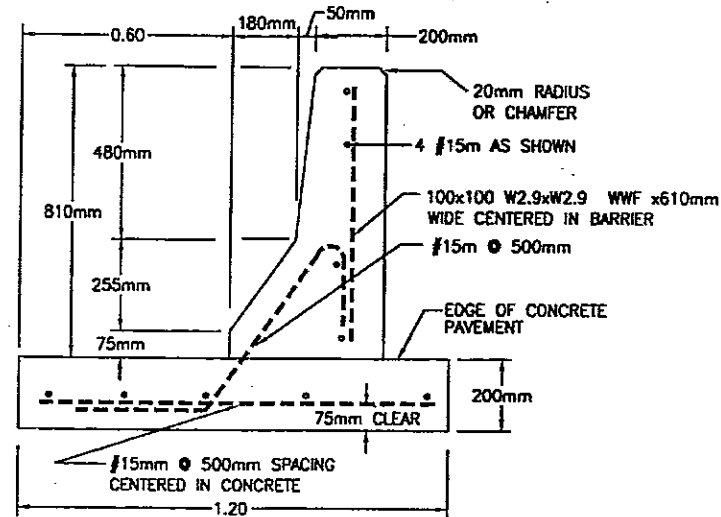

**CAST-IN-PLACE CONCRETE BARRIER**  
NOT TO SCALE

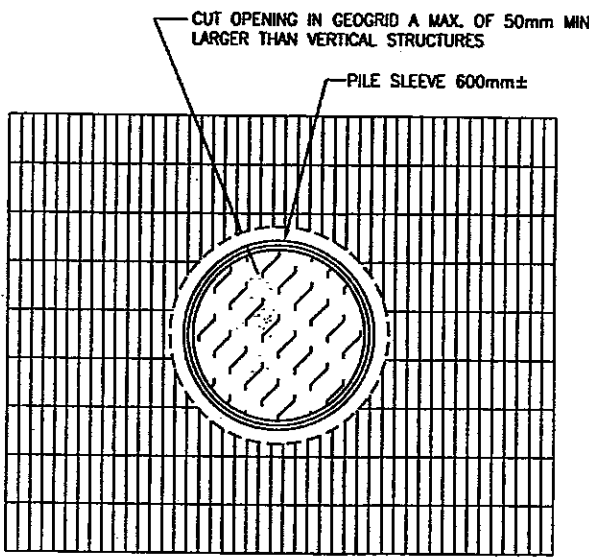

**GEOGRID PENETRATION**  
NOT TO SCALE

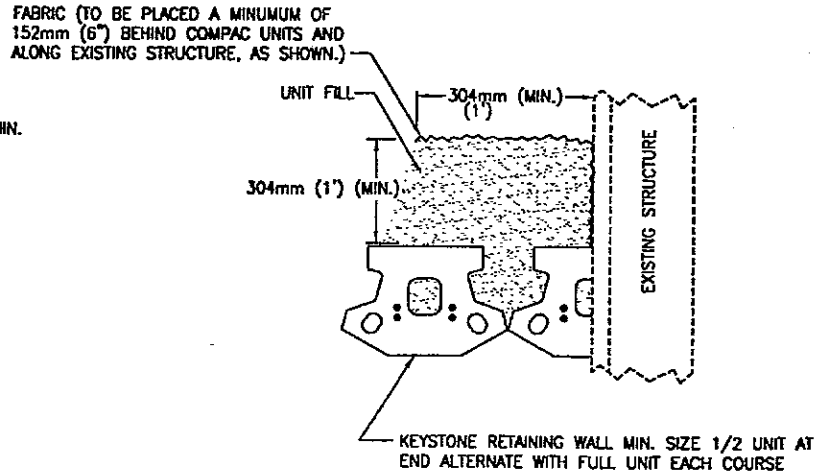

**KEYSTONE COMPAC UNIT AT EXISTING STRUCTURE**  
NOT TO SCALE

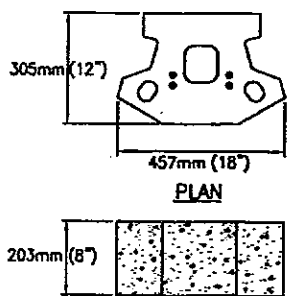

**KEYSTONE COMPAC BLOCK DETAIL**  
NOT TO SCALE

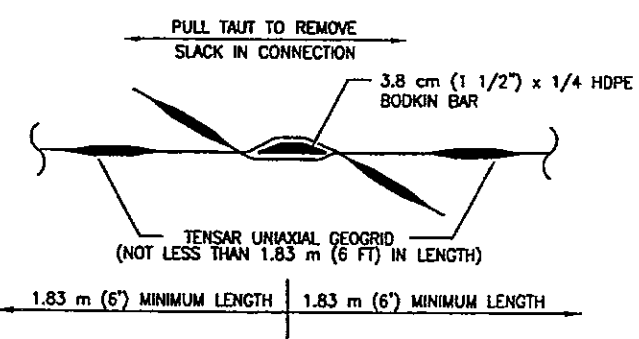

**BODKIN CONNECTION**  
NOT TO SCALE

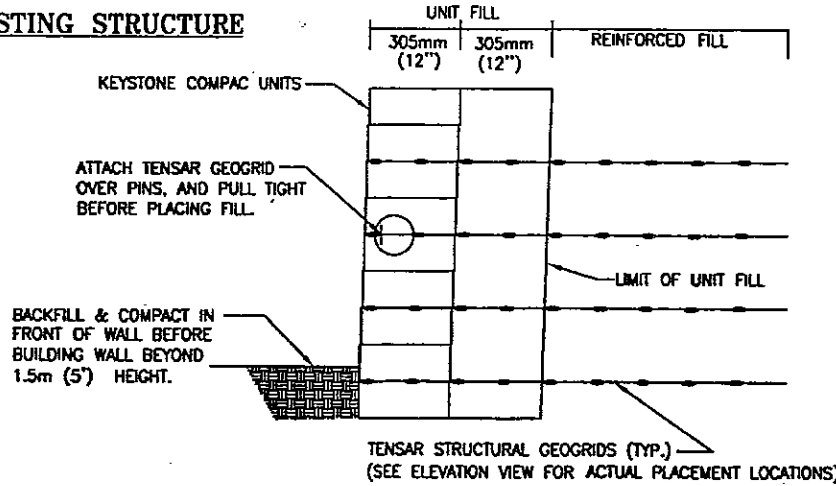

**LIMITS OF UNIT FILL/REINFORCED FILL & GEOGRID ATTACHMENT DETAIL**  
NOT TO SCALE

D968030T.DWG

THIS DESIGN IS BASED UPON SPECIFIC PROPERTIES OF TENSAR PRODUCTS (GEOGRIDS, DRAINAGE COMPOSITES AND EROSION MEDIA), WHICH ARE PROPRIETARY TO THE TENSAR CORPORATION 1210 CITIZENS PARKWAY, MORROW GA, 30260. ANY SUBSTITUTION OF THE SPECIFIED PRODUCTS WILL INVALIDATE THIS DESIGN. THIS DRAWING IS BEING FURNISHED FOR USE ON THIS SPECIFIC PROJECT ONLY. ANY PARTY ACCEPTING THIS DOCUMENT DOES SO IN CONFIDENCE AND AGREES THAT IT SHALL NOT BE DUPLICATED WHOLE OR IN PART, NOR DISCLOSED TO OTHERS, WITHOUT THE CONSENT OF TENSAR EARTH TECHNOLOGIES, INC.

THIS DRAWING, DESIGN NOTES AND ASSOCIATED CALCULATIONS HAVE BEEN PREPARED BY TENSAR EARTH TECHNOLOGIES, INC. FOR PRELIMINARY DESIGN PURPOSES AND SHALL NOT BE USED FOR FINAL DESIGN OR CONSTRUCTION.

COPYRIGHT 1996, TENSAR EARTH TECHNOLOGIES, INC.

**TENSAR**  
EARTH TECHNOLOGIES, INC.  
5775-B Glenridge Drive  
Lakeside Center Suite 450  
Atlanta, Georgia 30328  
(404) 250-1290

**GENESIS**  
REGISTERED PROFESSIONAL ENGINEER  
No. 7355  
D. DEGAN  
STATE OF UTAH

| REVISIONS \ ISSUE |                               |
|-------------------|-------------------------------|
| 2/26/96           | ISSUED FOR BID                |
| 12/30/96          | REVISED PER PS&E COMMENTS     |
| 2/3/97            | REVISED PER TERRACON COMMENTS |

Project Number  
D96803  
Date Drawn  
2/26/96  
Scale  
As Shown  
Designed by  
LSB/SEW  
Drawn by  
CYS/BBC  
Checked by  
SEW

**I-15 WIDENING**  
UNIVERSITY AVENUE INTERCHANGE MODIFICATIONS  
UTAH DOT PROJECT No. \*IHDP-15-6 (124) 26

PROVO, UTAH

**TYPICAL DETAILS**

Sheet Number  
10 of 10