

Date: 18-MAY-1999 Time: 16:23 User: ramesh.simon/h

Filename: c:\dgn\115.cadd\115_97.dwg - sheet - files\valis\13_retwall-01.dwg rev

RETAINING WALL DETAIL

WALL R-350-1
(2-STAGE MSE WALL)

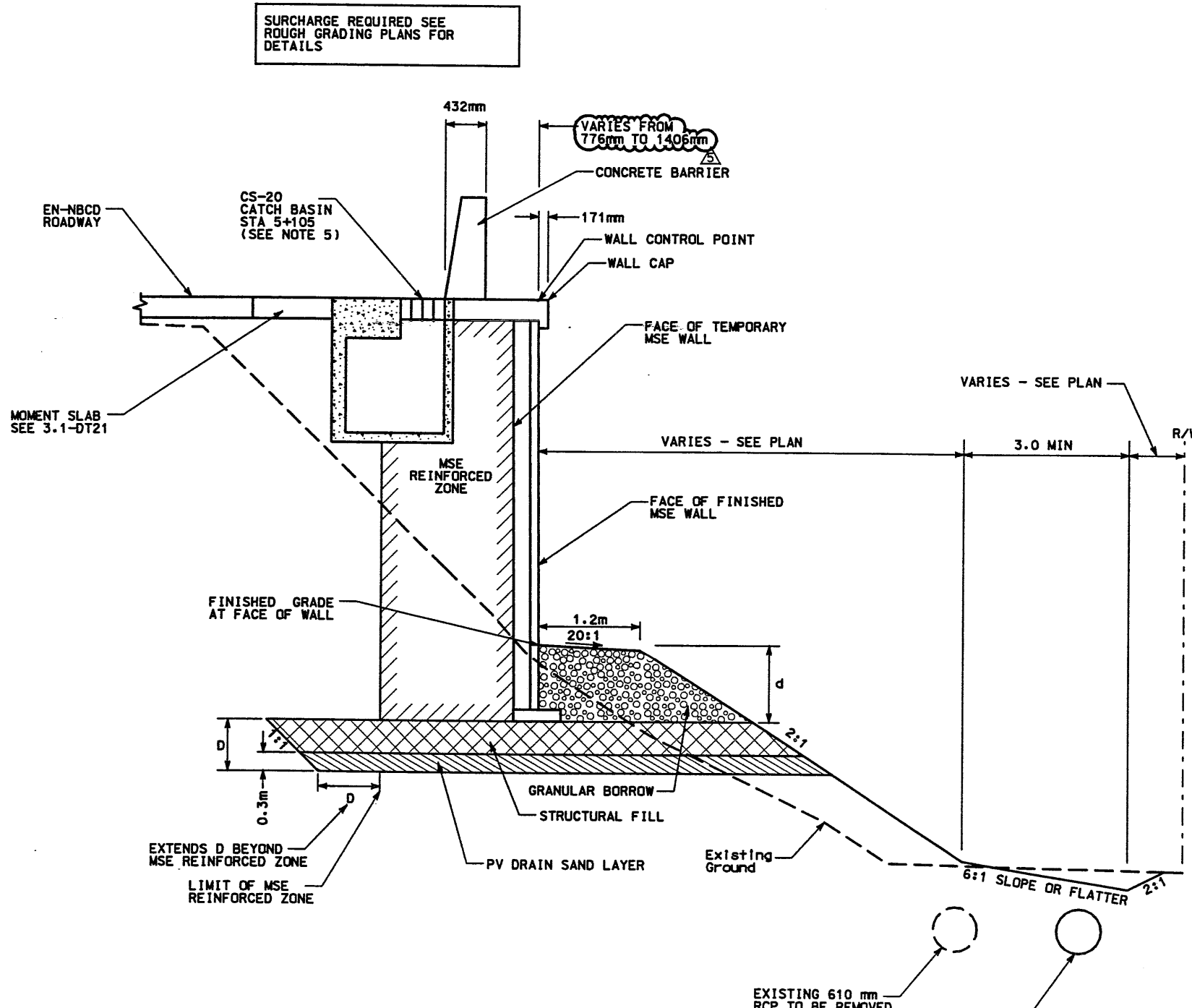

SURCHARGE REQUIRED SEE ROUGH GRADING PLANS FOR DETAILS

VARIES FROM 776mm TO 1406mm

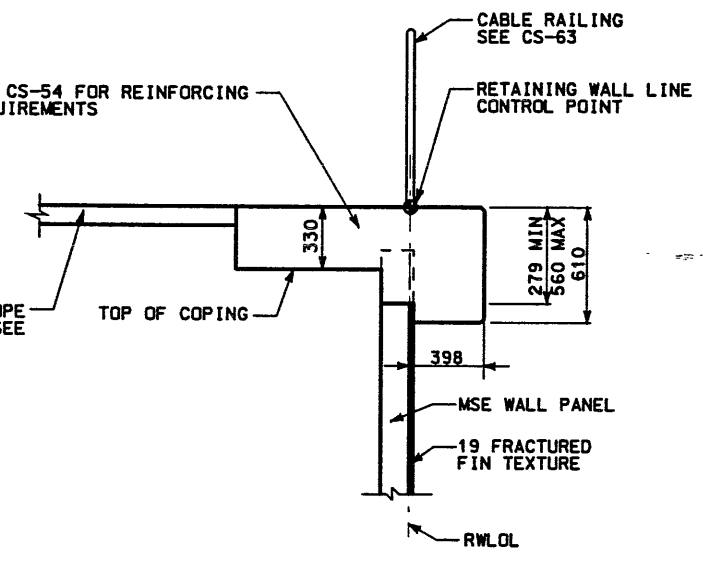

DETAIL B
STA 5+110.127 TO STA 5+116.985
NTS

WASATCH CONSTRUCTORS

JUN 17 1999

RELEASED FOR CONSTRUCTION

NOTES:

- 1) OVEREXCAVATE EXISTING SOILS TO DEPTH (D) OF 1.0m MINIMUM OR AS SHOWN ON VSL PLANS.
- 3) SEE CORRIDOR STANDARD SPECIFICATION 221 FOR SPECIAL EXCAVATION REQUIREMENTS WHERE GROUNDWATER IS EXPECTED AT OR ABOVE THE REQUIRED EXCAVATION ELEVATION.
- 4) SEE CORRIDOR STANDARD SPECIFICATION 210 FOR SPECIAL EXCAVATION AND BACKFILL REQUIREMENTS WHERE SOFT CLAYS OR OTHER SOFT AND/OR WET CONDITIONS ARE ENCOUNTERED.
- 5) FOR INFORMATION ONLY. EXISTING STORM DRAIN REPLACEMENT WILL NOT HAPPEN DURING CONSTRUCTION OF WALL R-350-1. SEE DRAINAGE PLANS AND PROFILES FOR ELEVATIONS AND LOCATIONS.
- 6) SEE ROUGH GRADING PACKAGE FOR REQUIRED SUB-EXCAVATION AND STABILITY BERM INFORMATION
- 7) COMPACTED GRANULAR BORROW. 1.5 H TO 1 V BENCHING REQUIRED AT CONNECTION OF NEW AND EXISTING SLOPES.
- 8) FROM STA 5+093.976 TO 5+106.004 SEE CS-54-9 SECTION R. THE WIDTH FROM RETAINING WALL LAYOUT POINT TO EDGE OF COPING VARIES FROM 870 TO 947 IN PLACE OF 427. FROM STA 5+106.004 TO 5+110.127 SEE BRIDGE DWG. F-634 SHT 8 OF 14 FOR SECTION DETAILS.

DETAIL A
STA 5+000 TO STA 5+093.976

d = EMBEDMENT DEPTH (SEE VSL PLANS)
D = DESIGN DEPTH OF STRUCTURAL FILL BENEATH WALL (SEE VSL PLANS)

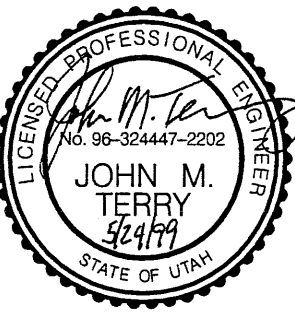

SEALED FOR RELEASE NO. 5 ONLY.
(REALIGNMENT OF RETAINING WALL CONTROL POINT DUE TO FIRST STAGE SETTLEMENT AND SECOND STAGE MSE PANEL ALIGNMENT)

APPROVED FOR CONSTRUCTION		DESCRIPTION	
NO.	DATE	DATE	DESCRIPTION
1	3/25/98	3/25/98	P8 EARLY G/DP/
2	5/21/98	5/21/98	98 EARLY FINAL ROADWAY
3	9/30/98	9/30/98	ADDED CABLE RAILING
4	5/19/99	5/19/99	RELEASE FOR 2ND STAGE CONSTRUCTION

UTAH DEPARTMENT OF TRANSPORTATION	WBS NO. 3112406
MK CENTENNIAL SVDRUP/DE LEUW	CHECK C.D. 10/02/97
DESIGN DMC 7/29/97	CHECK C.D. 10/02/97
DRWN NVA 7/31/97	CHECK C.D. 10/02/97
QUANT. JLB 3/17/98	CHECK JAB 3/19/98
PROJECT MANAGER	
APPROVAL DATE	DATE
10/02/97	10/02/97
Bret A. Reynolds	Randle L. Robb
PROJECT DESIGN ENGINEER	PROJECT MANAGER

I-15 CORRIDOR RECONSTRUCTION	SALT LAKE COUNTY
WALL DETAIL R-350-1	DWG. NO. 3.1R-350-1.2
SECTION 3.1	
#SP-15-7(135)296	
PROJECT NUMBER	
SHT. 2 OF 13	
REF.	

RFC After Final Approval

RETAINING WALL DETAIL

WALL R-350-1
(2-STAGE MSE WALL)

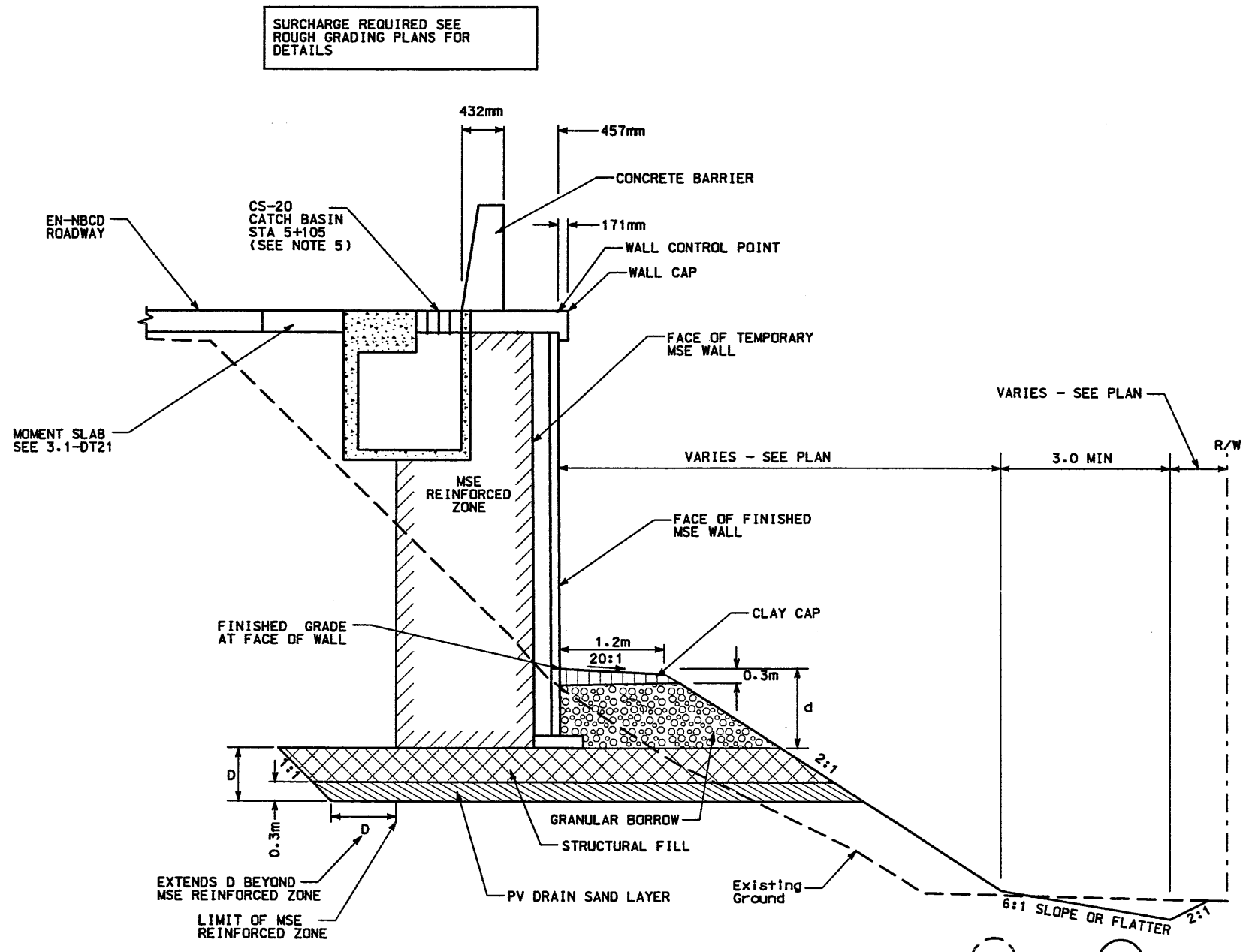

DETAIL A
STA 5+000 TO STA 5+109.522

d = EMBEDMENT DEPTH (SEE VSL PLANS)
D = DESIGN DEPTH OF STRUCTURAL FILL BENEATH WALL (SEE VSL PLANS)

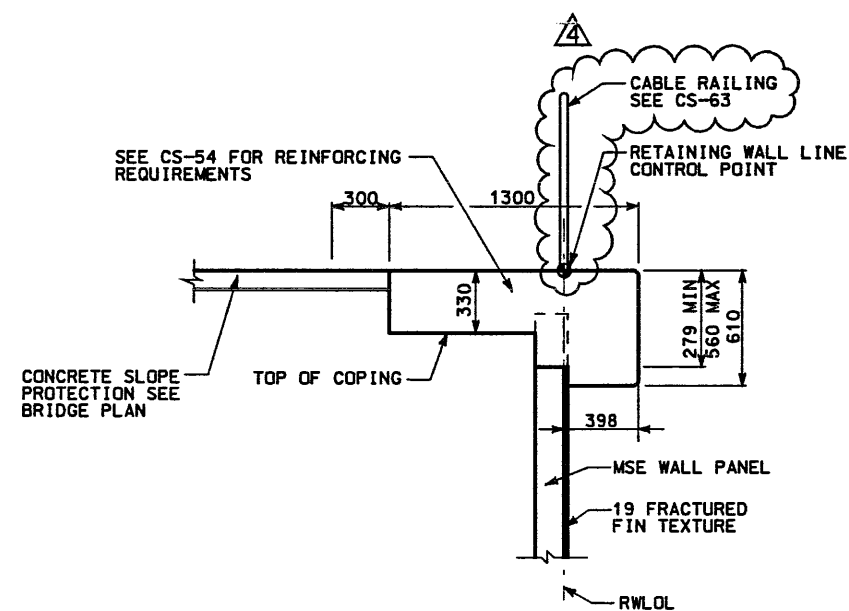

DETAIL B
STA 5+109.522 TO STA 5+116.919
NTS

WASATCH CONSTRUCTORS
OCT 07 1998
RELEASED FOR CONSTRUCTION

NOTES:

- 1) OVEREXCAVATE EXISTING SOILS TO DEPTH (D) OF 1.0m MINIMUM OR AS SHOWN ON VSL PLANS.
- 2) CONSTRUCT CLAY CAP WITH LOW PLASTIC SILTY CLAY (0.3m THICK).
- 3) SEE CORRIDOR STANDARD SPECIFICATION 221 FOR SPECIAL EXCAVATION REQUIREMENTS WHERE GROUNDWATER IS EXPECTED AT OR ABOVE THE REQUIRED EXCAVATION ELEVATION.
- 4) SEE CORRIDOR STANDARD SPECIFICATION 210 FOR SPECIAL EXCAVATION AND BACKFILL REQUIREMENTS WHERE SOFT CLAYS OR OTHER SOFT AND/OR WET CONDITIONS ARE ENCOUNTERED.
- 5) FOR INFORMATION ONLY, EXISTING STORM DRAIN REPLACEMENT WILL NOT HAPPEN DURING CONSTRUCTION OF WALL R-350-1. SEE DRAINAGE PLANS AND PROFILES FOR ELEVATIONS AND LOCATIONS.
- 6) SEE ROUGH GRADING PACKAGE FOR REQUIRED SUB-EXCAVATION AND STABILITY BERM INFORMATION
- 7) COMPACTED GRANULAR BORROW. 1.5 H TO 1 V BENCHING REQUIRED AT CONNECTION OF NEW AND EXISTING SLOPES.

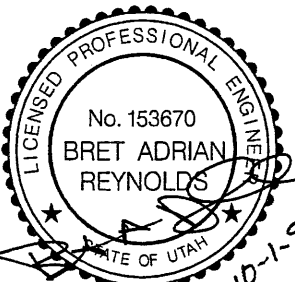

APPROVED FOR CONSTRUCTION		DESCRIPTION	
NO.	DATE	ORIGINAL ISSUE	
1	10/13/97	98 EARLY G/D/P	
2	3/25/98	98 EARLY FINAL ROADWAY	
3	5/21/98	ADDED CABLE RAILING	
4	9/30/98		
UTAH DEPARTMENT OF TRANSPORTATION		WBS NO. 3114000	
MK CENTENNIAL		DESIGN DMC	7/29/97
SVERDRUP/DE LEUW		CHECK CJD	10/02/97
		DRAWN MVM	7/31/97
		CHECK CJD	10/02/97
		QUANT. JBW	3/17/98
		CHECK JAB	3/19/98
PROJECT MANAGER		Bret A. Reynolds	
DATE		10/02/97	
PROJECT DESIGN ENGINEER		Randie L. Ross	
DATE		10/02/97	
PROJECT NUMBER		#SP-15-7(135)296	
I-15 CORRIDOR RECONSTRUCTION		SALT LAKE COUNTY	
WALL DETAIL R-350-1		DWG. NO. 3.1R-350-1.2	
SECTION 3.1		SHT. 2 OF 9	
		REF.	

TRENCH (X-UTAH.DWG)

APPROVED FOR CONSTRUCTION		
NO.	DATE	DESCRIPTION
10-06-97		RELEASE FOR 1ST STAGE CONST. ONLY
05-10-99		RELEASE FOR 2ND STAGE CONSTRUCTION

NO.	DATE	REVISION	BY

VSL CORPORATION
 2800 Plaza Place, Suite 200
 Raleigh, NC 27617
 Telephone (919) 781 6772
 Fax (919) 781 4999



ATLANTA, GA / DENVER, CO / HOUSTON, TX / CHICAGO, IL / PHOENIX, AZ / SAN JOSE, CA / SPANISH WALK, NJ

VSL Corporation (VSL) is a leading provider of innovative and cost-effective solutions for retaining walls, earth retention, and foundation systems. VSL's extensive experience and global presence ensure that we can provide the highest quality of service and support to our clients worldwide. VSL's commitment to innovation and excellence is reflected in our advanced design and construction techniques, which have resulted in numerous successful projects around the world. VSL's dedication to safety and quality is a cornerstone of our business, and we are committed to providing the most reliable and durable solutions for our clients' needs.

RETAINED EARTH™ WALLS
PLAN VIEW MSE WALL "R-350-1"
UTAH I-15 INTERCHANGE
SALT LAKE COUNTY, UTAH
UTAH DEPARTMENT OF TRANSP.
DWG. NO.
3.1R-350-1.3
JOB NO.
239-0007
SHT. NO.
RE-1

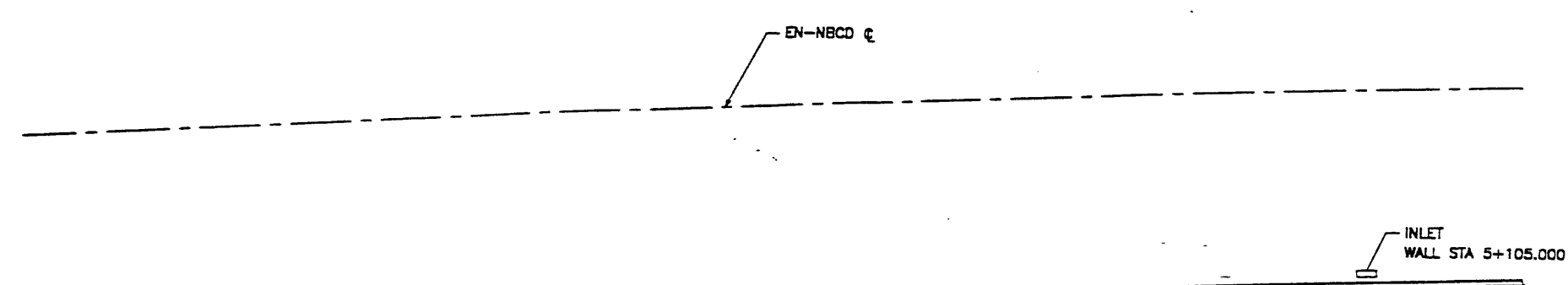

WIRE FACED WALL STA 5+000.000 =
 EN-NBCD STA 1+408.262
 ● 14.832 RT
 BEGIN WIRE FACED WALL R-350-1

PRECAST WALL STA 5+000.000 =
 EN-NBCD STA 1+408.262
 ● 15.289 RT
 BEGIN PRECAST WALL R-350-1

PRECAST WALL STA 5+000.000 =
 EN-NBCD STA 1+408.263
 ● 15.608 RT
 BEGIN PRECAST WALL R-350-1

R=15545.00m
 $\Delta = 0^{\circ}25'51''$
 L=116.895m
 T=58.448m

CURVE DATA				
No.	RADIUS	LENGTH	TANGENT	Δ
1	2284.711	116.819	58.472	02°55'55" RT

All Dimensions Are in Meters Unless Noted Otherwise

PRECAST WALL STA 5+116.919 =
 EN-NBCD STA 1+525.963
 ● 15.289 RT
 END PRECAST WALL R-350-1

PRECAST WALL STA 5+116.895 =
 EN-NBCD STA 1+525.969
 ● 15.593 RT
 END PRECAST WALL R-350-1

WIRE FACED WALL STA 5+116.919 =
 EN-NBCD STA 1+525.963
 ● 14.832 RT
 END WIRE FACED WALL R-350-1

PLAN VIEW MSE WALL "R-350-1"

SCALE: 1=250 (FULL SIZE)
 SCALE: 1=500 (HALF SIZE)

RETAINED EARTH INDEX	
RE-1	PLAN WIRE FACED WALL R-350-1, NOTES & DESIGN CRITERIA
RE-2	WALL CONNECTION DETAILS @ STAGE CONST.
RE-3	TYPICAL DETAILS
RE-4	TYPICAL CROSS SECTIONS @ WIRE FACED WALL
RE-5	TYPICAL CROSS SECTION
RE-6	WIRE FACED WALL R-350-1
RE-7	WIRE FACED WALL R-350-1
RE-8	PRECAST WALL R-350-1
RE-9	PRECAST WALL R-350-1
RE-10	SPECIAL PANEL DETAILS
RE-10	SPECIAL PANEL DETAILS

NOTE
 THE WALL CONNECTIONS ON WALL 350-01 MAY BE ROTATED A MAXIMUM OF 55° VERTICALLY (COL 1 - 31) AND 42° VERTICALLY (COL 32 - 38). SEE DETAIL "SECTION ROTATED" ON VSL STANDARD DRAWING NO. 18 FOR MORE INFORMATION.

2ND STAGE DESIGN
 BASED ON POST SETTLEMENT SURVEY OF THE WIRE FACE, LATERAL OUTWARD DISPLACEMENTS RANGED FROM -156mm TO 879mm MEASURED AT THE BASE OF THE WALL.

DESIGN PARAMETERS	
ANGLE OF INTERNAL FRICTION (SELECT)	= 34°
ANGLE OF INTERNAL FRICTION (BASE)	= 30°
ANGLE OF INTERNAL FRICTION (RANDOM)	= 34°
UNIT WEIGHT BACKFILL	= 135 PCF. (21.2 KN/M ³)
TRAFFIC SURCHARGE	= 250 PSF
SEISMIC ACCELERATION COFF.	= 0.27g (TYP)
SEISMIC ACCELERATION COFF.	= 0.68g (AT BRIDGE ABUTMENTS)
DESIGN CRITERIA	
SAFETY FACTOR (OVERTURNING)	= 2.0
SAFETY FACTOR (SLIDING)	= 1.5
SAFETY FACTOR (PULLOUT)	= 1.5
DESIGN LIFE	= 75 YEARS

WASATCH CONSTRUCTORS
 JUN 17 1999
 RELEASED FOR CONSTRUCTION

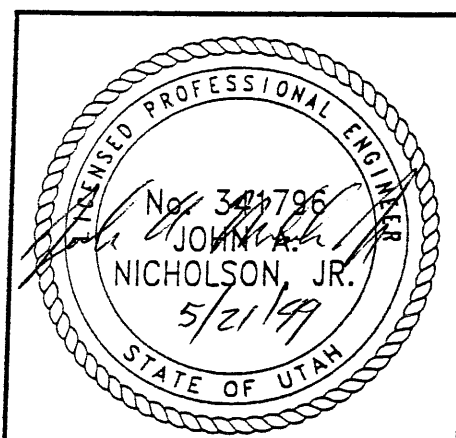

METRIC
 CERTIFIED FOR INTERNAL STABILITY OF RETAINED EARTH™ STRUCTURES ONLY. EXTERNAL STABILITY, INCLUDING BUT NOT LIMITED TO FOUNDATION AND SLOPE STABILITY, IS THE RESPONSIBILITY OF THE OWNER. DESIGN IS BASED ON THE ASSUMPTION THAT THE MATERIAL WITHIN THE RETAINED EARTH™ MASS, METHODS OF CONSTRUCTION, AND QUALITY OF PREFABRICATED MATERIALS CONFORM TO THE MANUFACTURER'S SPECIFICATION.

RFC After Final Approval

C:\MSE-DWG\13-SERIES\13-101-2-STAGE\RE-1A

UTAH FLUT 03-10-99

APPROVED FOR CONSTRUCTION		
NO.	DATE	DESCRIPTION
△	10-06-97	RELEASE FOR 1ST STAGE CONST. ONLY <i>OK</i>

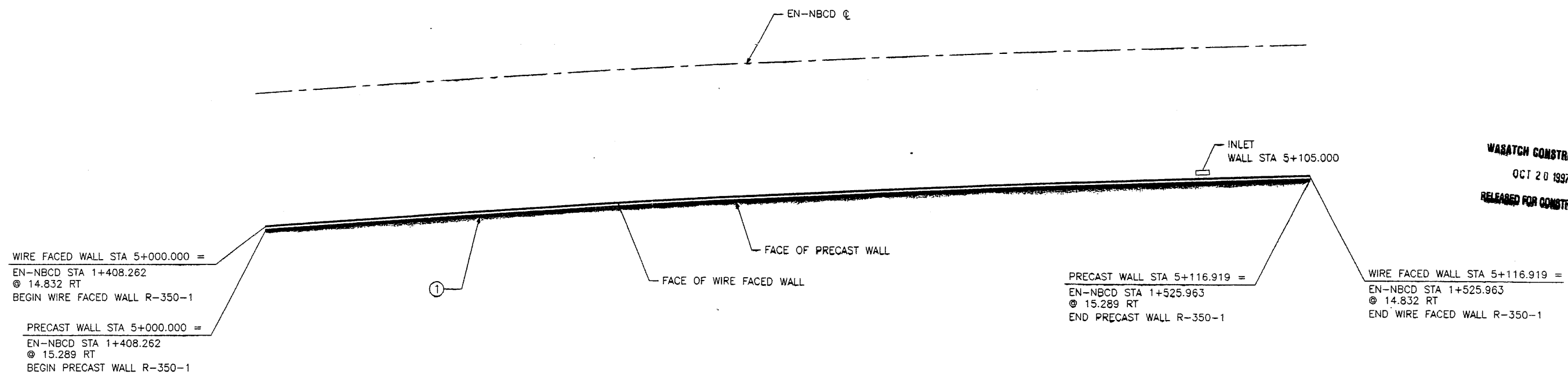

WIRE FACED WALL STA 5+000.000 =
 EN-NBCD STA 1+408.262
 @ 14.832 RT
 BEGIN WIRE FACED WALL R-350-1

PRECAST WALL STA 5+000.000 =
 EN-NBCD STA 1+408.262
 @ 15.289 RT
 BEGIN PRECAST WALL R-350-1

PRECAST WALL STA 5+116.919 =
 EN-NBCD STA 1+525.963
 @ 15.289 RT
 END PRECAST WALL R-350-1

WIRE FACED WALL STA 5+116.919 =
 EN-NBCD STA 1+525.963
 @ 14.832 RT
 END WIRE FACED WALL R-350-1

CURVE DATA				
No.	RADIUS	LENGTH	TANGENT	△
①	2284.711	116.919	58.472	02°55'55" RT

All Dimensions Are In Meters Unless Noted Otherwise

PLAN VIEW MSE WALL "R-350-1"

SCALE: 1=250 (FULL SIZE)
 SCALE: 1=500 (HALF SIZE)

RETAINED EARTH INDEX	
RE-1	PLAN WIRE FACED WALL R-350-1, NOTES & DESIGN CRITERIA
RE-2	WALL CONNECTION DETAILS @ STAGE CONST.
RE-3	TYPICAL DETAILS
RE-4	TYPICAL CROSS SECTIONS @ WIRE FACED WALL
RE-5	TYPICAL CROSS SECTION
RE-6	WIRE FACED WALL R-350-1
RE-7	WIRE FACED WALL R-350-1

DESIGN PARAMETERS	
ANGLE OF INTERNAL FRICTION (SELECT)	= 34°
ANGLE OF INTERNAL FRICTION (BASE)	= 30°
ANGLE OF INTERNAL FRICTION (RANDOM)	= 34°
UNIT WEIGHT BACKFILL	= 135 PCF. (21.2 KN/M ³)
TRAFFIC SURCHARGE	= 250 PSF
SEISMIC ACCELERATION COFF.	= 0.27g (TYP)
SEISMIC ACCELERATION COFF.	= 0.68g (AT BRIDGE ABUTMENTS)
DESIGN CRITERIA	
SAFETY FACTOR (OVERTURNING)	= 2.0
SAFETY FACTOR (SLIDING)	= 1.5
SAFETY FACTOR (PULLOUT)	= 1.5
DESIGN LIFE	= 75 YEARS

METRIC

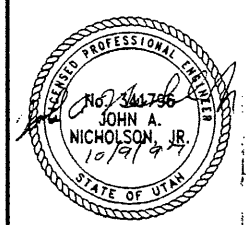

CERTIFIED FOR INTERNAL STABILITY OF RETAINED EARTH™ STRUCTURES ONLY. EXTERNAL STABILITY, INCLUDING BUT NOT LIMITED TO FOUNDATION AND SLOPE STABILITY, IS THE RESPONSIBILITY OF THE OWNER. DESIGN IS BASED ON THE ASSUMPTION THAT THE MATERIAL WITHIN THE RETAINED EARTH™ MASS, METHODS OF CONSTRUCTION, AND QUALITY OF PREFABRICATED MATERIALS CONFORM TO THE MANUFACTURER'S SPECIFICATION.

DES. 09-22-97 MM
 DRN. 09-22-97 DDD
 CHK. 09-22-97 MM

WASATCH CONSTRUCTORS
 OCT 20 1997
 RELEASED FOR CONSTRUCTION

VSL CORPORATION
 2840 Plaza Place, Suite 200
 Raleigh, NC 27612
 Telephone: (919) 781-6272
 Fax: (919) 781-4989

RETAINED EARTH™

RETAINED EARTH™ WALLS
 PLAN VIEW MSE WALL "R-350-1"
 UTAH I-15 INTERCHANGE
 SALT LAKE COUNTY, UTAH
 UTAH DEPARTMENT OF TRANSPORTATION

SCALE: 3.1R-350-1.3
 JOB NO: 239-0007
 RE-1

FINAL 10-06-97 E:\PROJECT\239-0007\1SERIES\13-101

She 3 of 9

E:\PROJECT\239-0007\13SERIES\13-101

FINAL 10-06-97

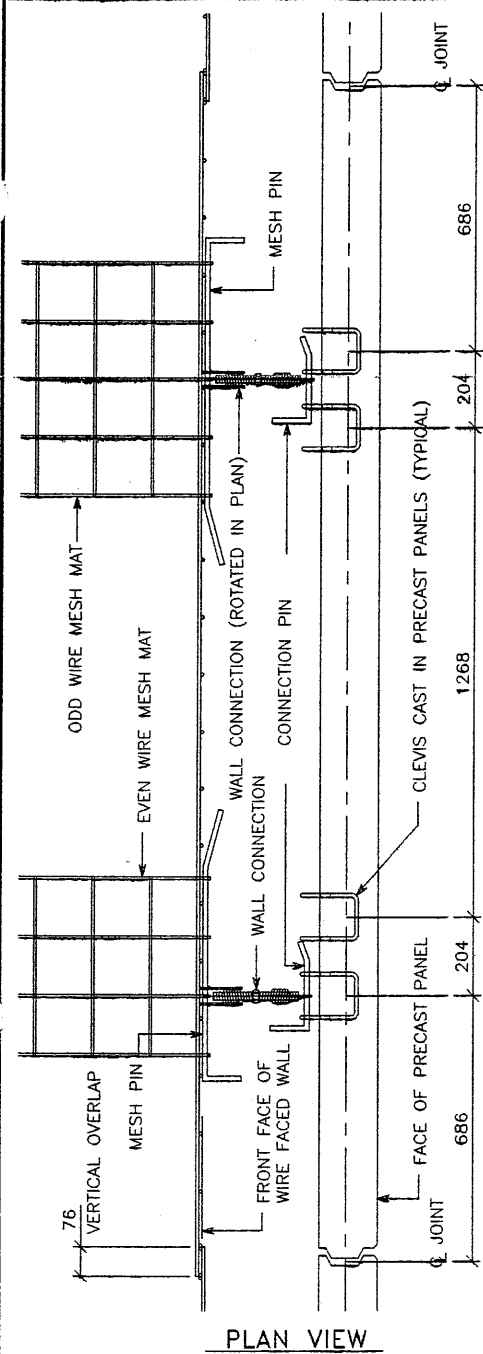

PLAN VIEW

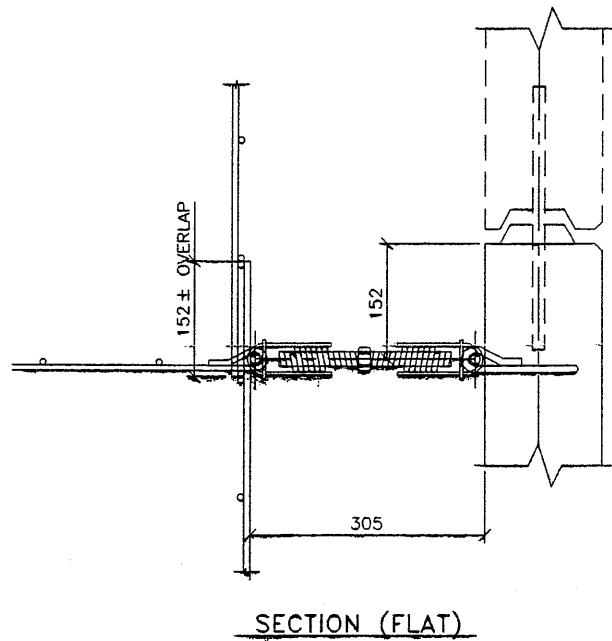

SECTION (FLAT)

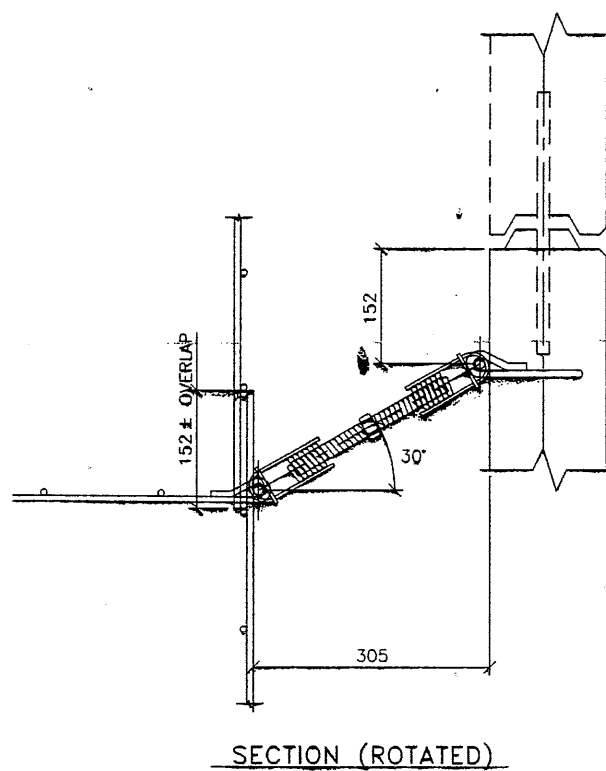

SECTION (ROTATED)

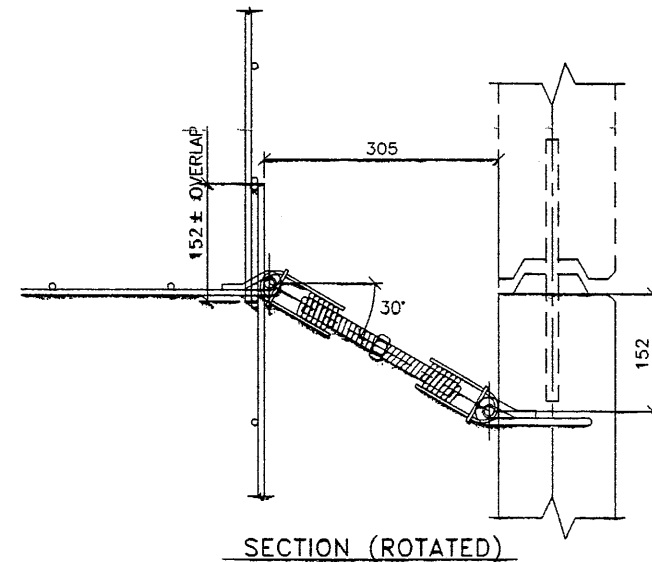

SECTION (ROTATED)

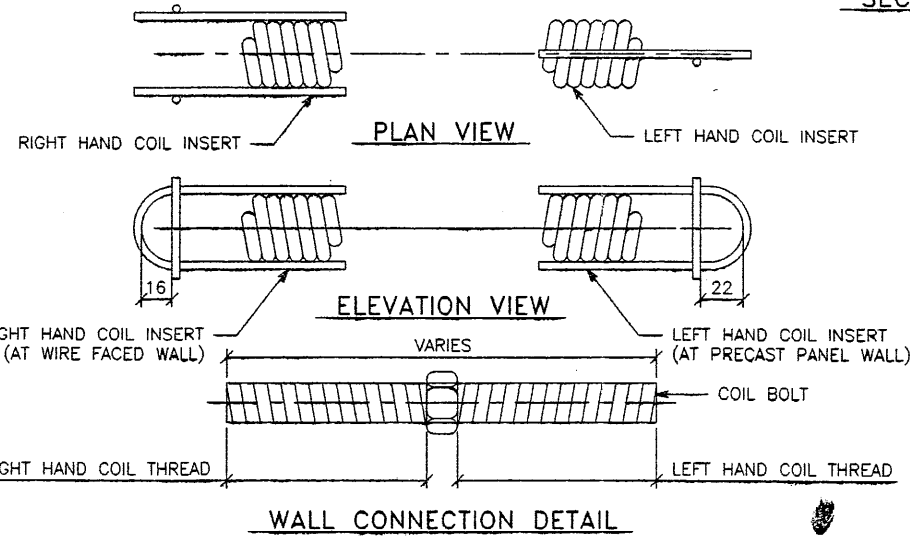

WALL CONNECTION DETAIL

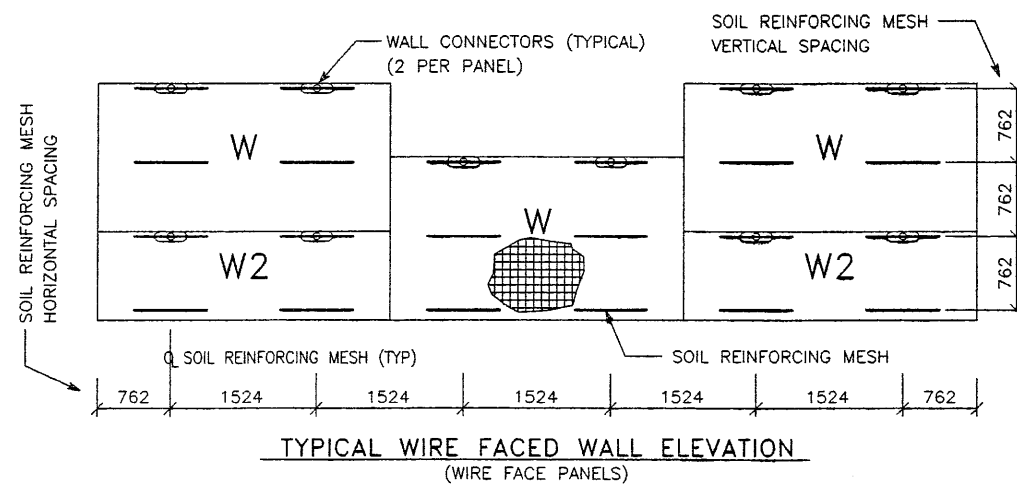

TYPICAL WIRE FACED WALL ELEVATION (WIRE FACE PANELS)

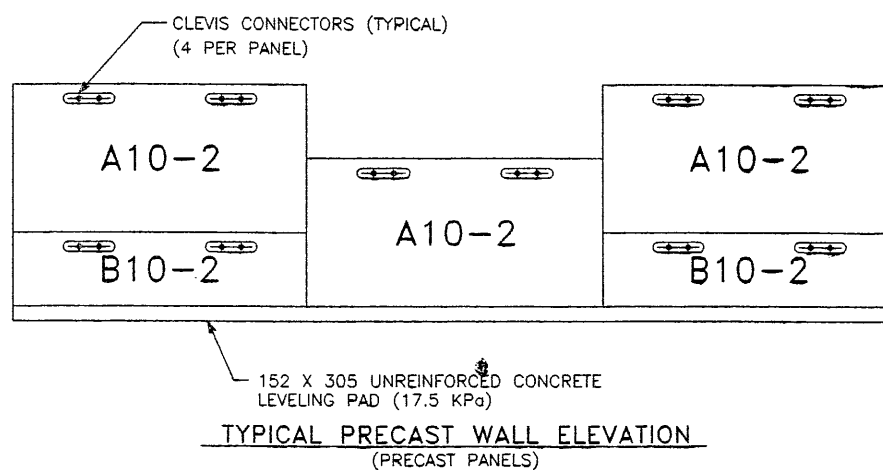

TYPICAL PRECAST WALL ELEVATION (PRECAST PANELS)

APPROVED FOR CONSTRUCTION		
NO.	DATE	DESCRIPTION
△	10-06-97	RELEASE FOR 1ST STAGE CONST. ONLY <i>RS</i>

WASATCH CONSTRUCTORS
OCT 20 1997
RELEASED FOR CONSTRUCTION

VSL CORPORATION
2840 Plaza Place, Suite 200
Raleigh, NC 27612
Telephone: (919) 781-4272
Fax: (919) 781-4969

DES. 09-22-97 MM
DRN. 09-22-97 DDO
CHK. 09-22-97 MM

RETAINED EARTH™

ATLANTA, GA / DALLAS, TX / RALEIGH, NC (CORPORATE OFFICE)

VSL Corporation (VSL) makes a strict proprietary disclaimer of all rights in the information and calculations herein. The information and calculations herein are the property of VSL Corporation and are not to be used, copied, or disseminated in any form without the written consent of VSL Corporation. VSL Corporation is not responsible for any errors or omissions in this information and calculations. VSL Corporation is not responsible for any damage or injury resulting from the use of this information and calculations. VSL Corporation is not responsible for any damage or injury resulting from the use of this information and calculations. VSL Corporation is not responsible for any damage or injury resulting from the use of this information and calculations.

RETAINED EARTH™ WALLS
WIRE FACED WALL "R-350-1"
WALL CONNECTION DETAILS @ STAGE CONST.
UTAH I-15 INTERCHANGE
SALT LAKE COUNTY, UTAH
UTAH DEPARTMENT OF TRANSP.

METRIC

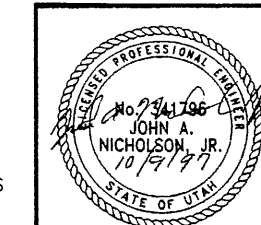

CERTIFIED FOR INTERNAL STABILITY OF RETAINED EARTH™ STRUCTURES ONLY. EXTERNAL STABILITY, INCLUDING BUT NOT LIMITED TO FOUNDATION AND SLOPE STABILITY, IS THE RESPONSIBILITY OF THE OWNER. DESIGN IS BASED ON THE ASSUMPTION THAT THE MATERIAL WITHIN THE RETAINED EARTH™ MASS, METHODS OF CONSTRUCTION, AND QUALITY OF PREFABRICATED MATERIALS CONFORM TO THE MANUFACTURER'S SPECIFICATION.

SCALE:	3.1R-350-1.4
JOB NO:	239-0007
	RE-2

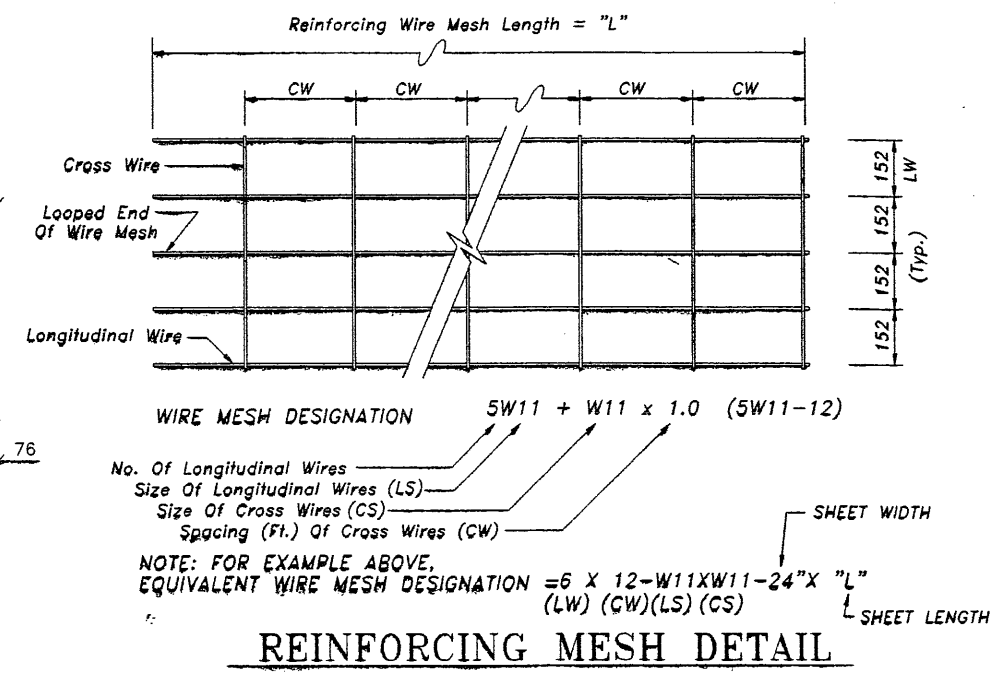
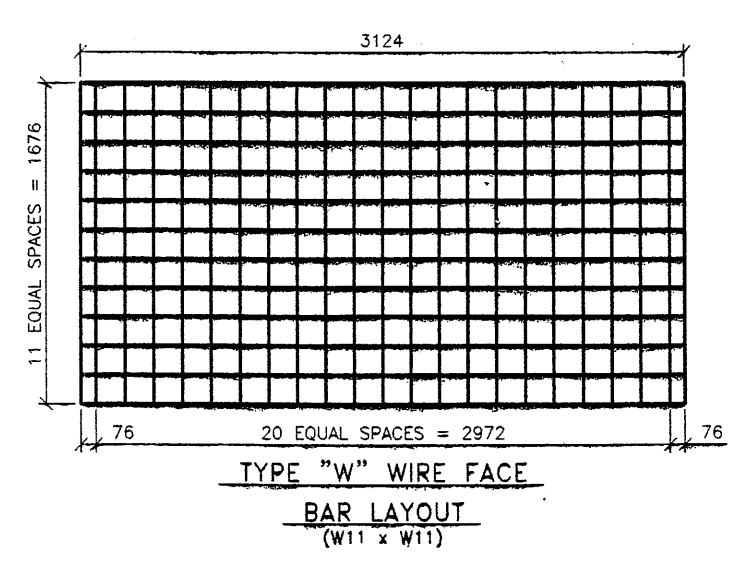
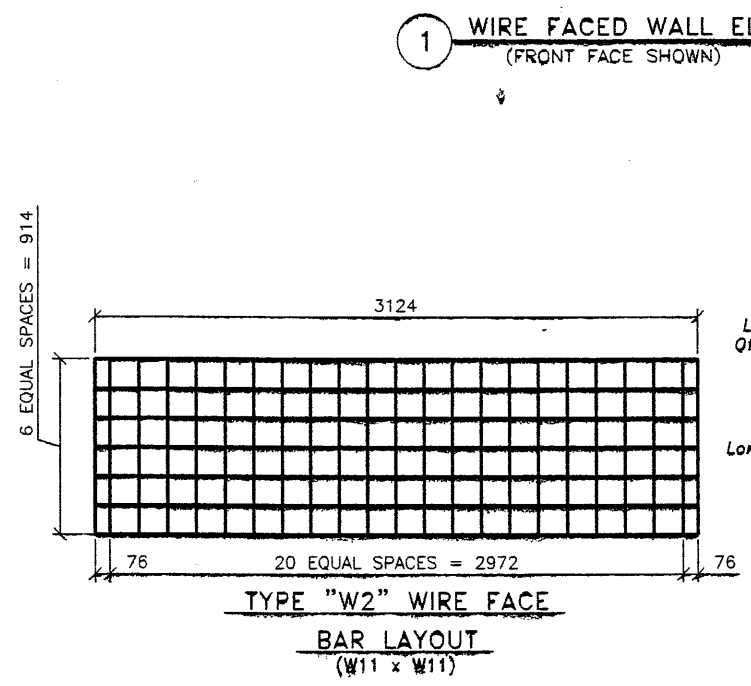
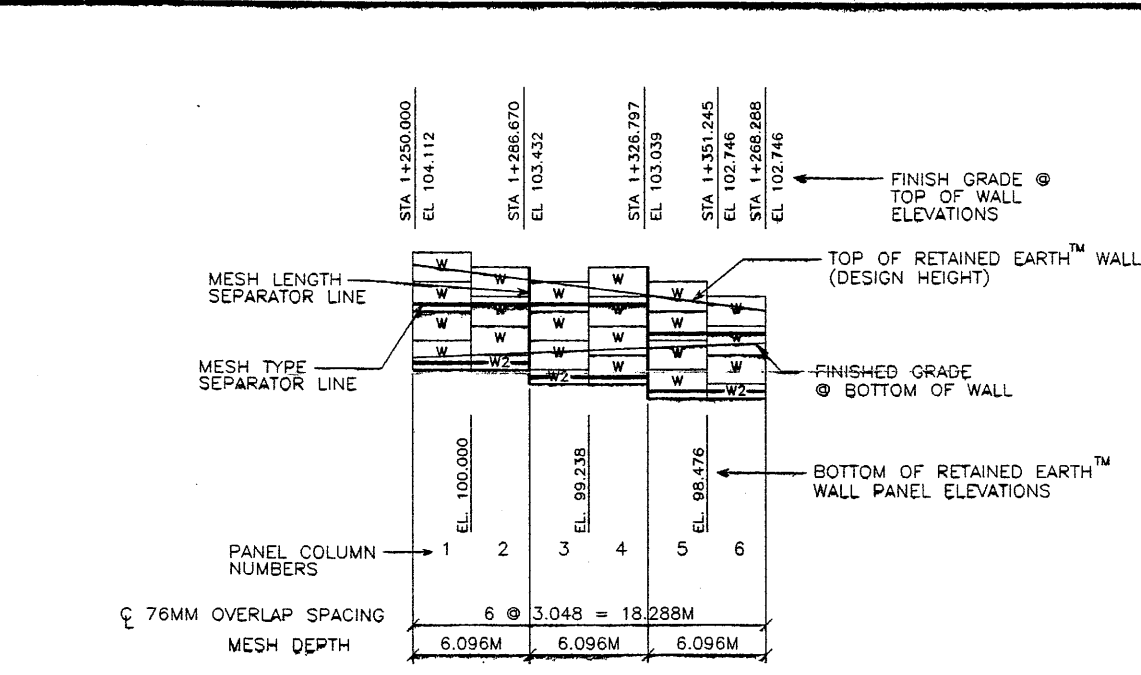
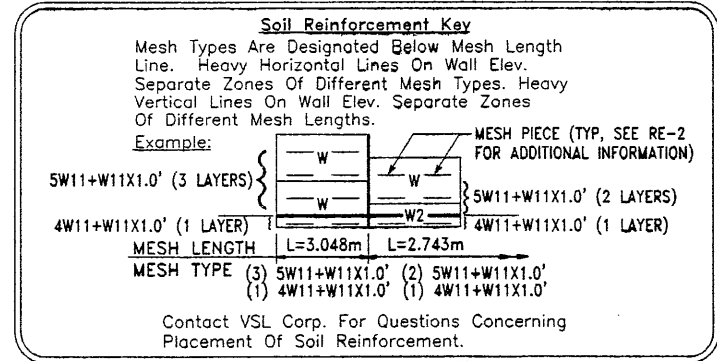
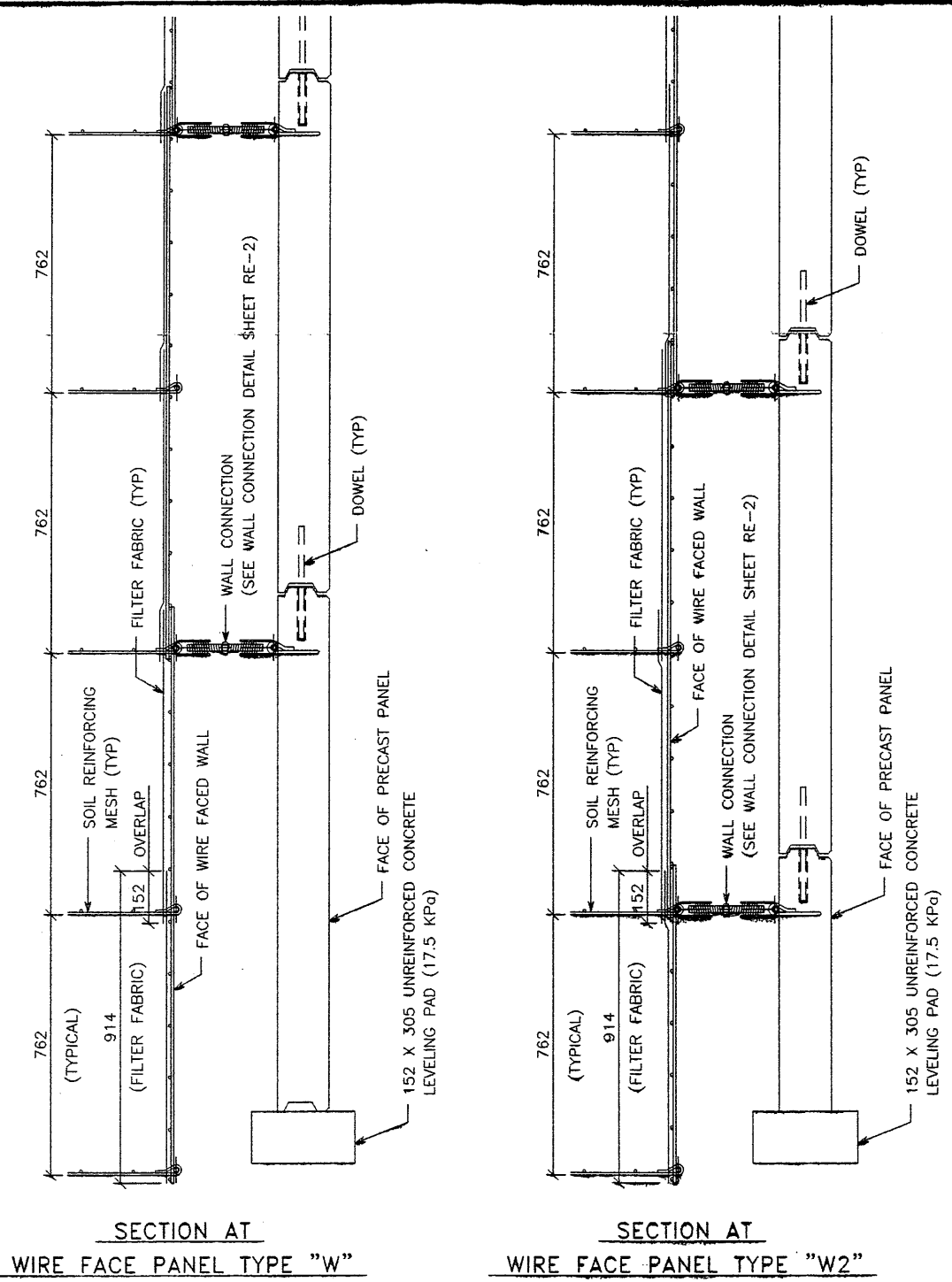

NOTE: W11 (71 sq mm) And W20 (129 sq mm) Steel Wire Material And Welding Of Cross Wires And Loops Shall Conform To ASTM A82 And ASTM 185, Fy = 448 MPa. Mesh Shall Be Galvanized To ASTM A-123 To A Minimum Effective Thickness Of 0.086 mm.

APPROVED FOR CONSTRUCTION

NO.	DATE	DESCRIPTION
△	10-06-97	RELEASE FOR 1ST STAGE CONST. ONLY

WABATCH CONSTRUCTORS
OCT 20 1997
RELEASED FOR CONSTRUCTION

DES.	MM	DDO	MM
09-22-97			
DRN.	09-22-97		
CHK.	09-22-97		

RETAINED EARTH™

VSL CORPORATION
2540 Plaza Place, Suite 200
Raleigh, NC 27612
Telephone: (919) 781-4272
Fax: (919) 781-4869



VSL Corporation (VSL) is a registered professional engineer and architect in the State of Utah. VSL is not responsible for the design or construction of any structure unless it is specifically stated on the drawings that VSL is the designer or architect for that structure.

RETAINED EARTH™ WALLS
WIRE FACED WALL "R-350-1"
TYPICAL DETAILS

UTAH I-15 INTERCHANGE
SALT LAKE COUNTY, UTAH
UTAH DEPARTMENT OF TRANSPORTATION

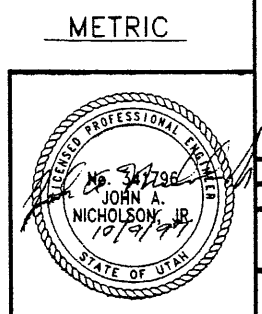

CERTIFIED FOR INTERNAL STABILITY OF RETAINED EARTH™ STRUCTURES ONLY. EXTERNAL STABILITY, INCLUDING BUT NOT LIMITED TO FOUNDATION AND SLOPE STABILITY, IS THE RESPONSIBILITY OF THE OWNER. DESIGN IS BASED ON THE ASSUMPTION THAT THE MATERIAL WITHIN THE RETAINED EARTH™ MASS, METHODS OF CONSTRUCTION, AND QUALITY OF PREFABRICATED MATERIALS CONFORM TO THE MANUFACTURER'S SPECIFICATION.

SCALE: 3.1R-350-1.5

JOB NO: 239-0007

RE-3

APPROVED FOR CONSTRUCTION		
NO.	DATE	DESCRIPTION
△	10-06-97	RELEASE FOR 1ST STAGE CONST. ONLY

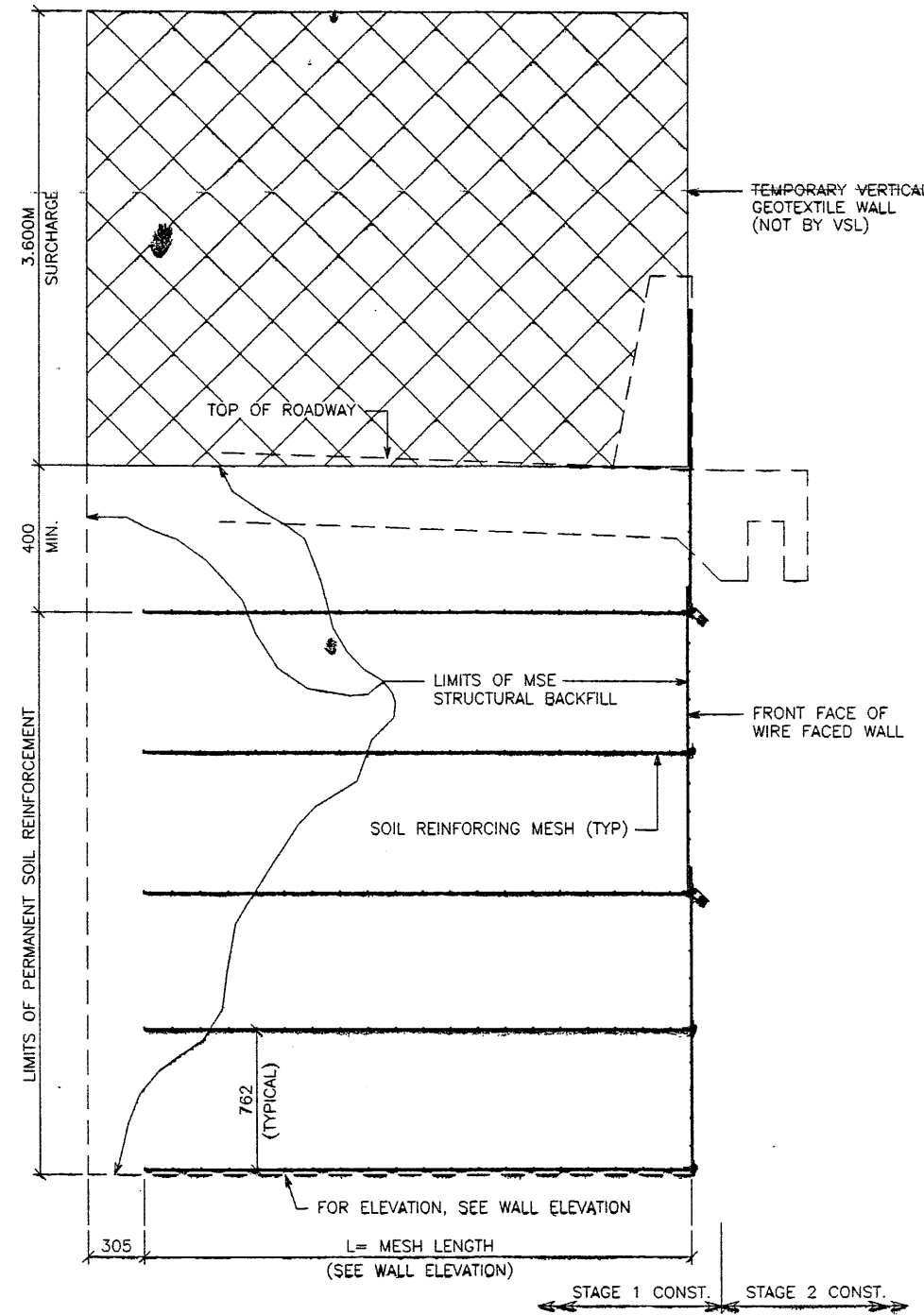

TYPICAL CROSS SECTION
AT FINAL PHASE OF WIRE FACE WALL
 SCALE: 1:20 (FULL SIZE)
 SCALE: 1:40 (HALF SIZE)

WARATCH CONSTRUCTORS
 OCT 20 1997
 RELEASED FOR CONSTRUCTION



VSL CORPORATION
 2840 Phoebe Place, Suite 200
 Bethesda, MD 20813
 Telephone: (301) 781-6272
 Fax: (301) 781-4869

VSL Corporation ("VSL")
 retains all rights in all drawings, specifications, and calculations prepared by VSL for the project. The use of such information in any other project without the written consent of VSL is prohibited. Any other use is strictly prohibited.

RETAINED EARTH™ WALLS
 WIRE FACED WALL "R-350-1"
 TYPICAL SECTIONS @ WIRE FACED WALL
 UTAH I-15 INTERCHANGE
 SALT LAKE COUNTY, UTAH
 UTAH DEPARTMENT OF TRANSPORTATION

METRIC

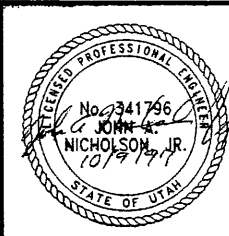

CERTIFIED FOR INTERNAL STABILITY OF RETAINED EARTH™ STRUCTURES ONLY. EXTERNAL STABILITY, INCLUDING BUT NOT LIMITED TO FOUNDATION AND SLOPE STABILITY, IS THE RESPONSIBILITY OF THE OWNER. DESIGN IS BASED ON THE ASSUMPTION THAT THE MATERIAL WITHIN THE RETAINED EARTH™ MASS, METHODS OF CONSTRUCTION, AND QUALITY OF PREFABRICATED MATERIALS CONFORM TO THE MANUFACTURER'S SPECIFICATION.

SCALE: 3.1R-350-1.6
 JOB NO: 239-0007
 RE-4

E:\PROJECT\239-0007\13SERIES\13-10

FINAL 10-06-97

APPROVED FOR CONSTRUCTION		
NO.	DATE	DESCRIPTION
△	10-06-97	RELEASE FOR 1ST STAGE CONST. ONLY <i>OR</i>

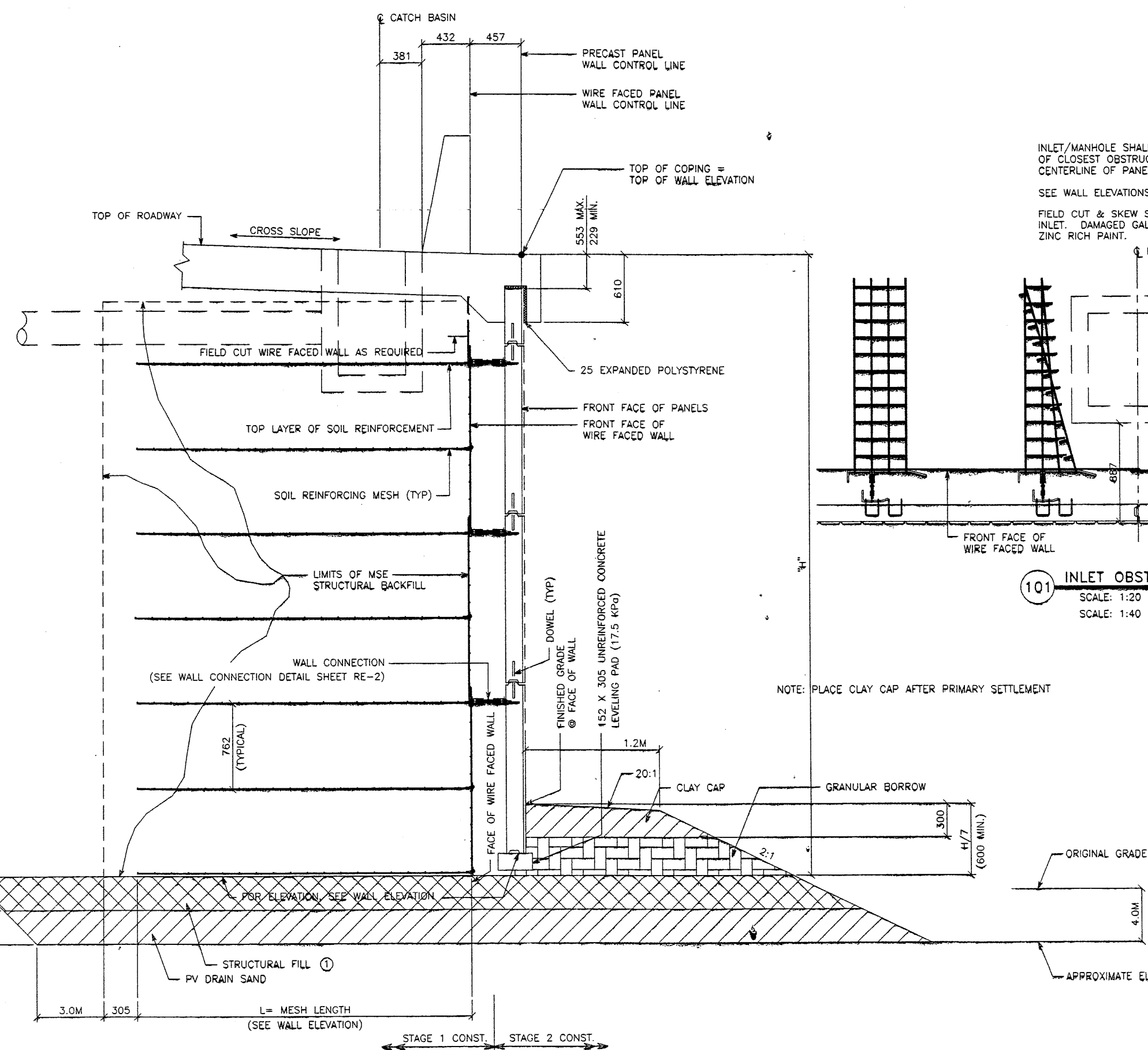

INLET/MANHOLE SHALL BE CENTERED ON CENTERLINE OF CLOSEST OBSTRUCTED PANEL JOINT OR CENTERLINE OF PANEL.

SEE WALL ELEVATIONS FOR LOCATION.

FIELD CUT & SKEW SOIL REINFORCING TO AVOID INLET. DAMAGED GALVANIZING SHALL BE COATED WITH ZINC RICH PAINT.

WASATCH CONSTRUCTORS
OCT 20 1997
RELEASED FOR CONSTRUCTION

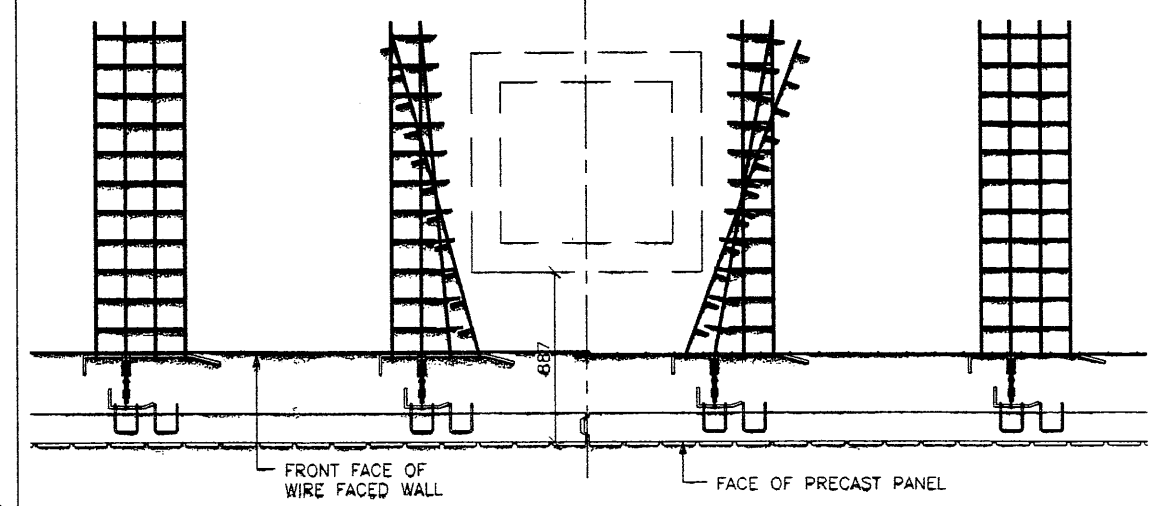

101 INLET OBSTRUCTION DETAIL
SCALE: 1:20 (FULL SIZE)
SCALE: 1:40 (HALF SIZE)

NOTE: PLACE CLAY CAP AFTER PRIMARY SETTLEMENT

TYPICAL CROSS SECTION
SCALE: 1:20 (FULL SIZE)
SCALE: 1:40 (HALF SIZE)

CERTIFIED FOR INTERNAL STABILITY OF RETAINED EARTH™ STRUCTURES ONLY. EXTERNAL STABILITY, INCLUDING BUT NOT LIMITED TO FOUNDATION AND SLOPE STABILITY, IS THE RESPONSIBILITY OF THE OWNER. DESIGN IS BASED ON THE ASSUMPTION THAT THE MATERIAL WITHIN THE RETAINED EARTH™ MASS, METHODS OF CONSTRUCTION, AND QUALITY OF PREFABRICATED MATERIALS CONFORM TO THE MANUFACTURER'S SPECIFICATION.

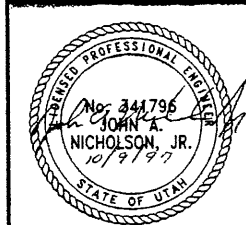

METRIC

VSL CORPORATION
2640 Flinn Plaza, Suite 200
Salt Lake City, UT 84119
Tel: (801) 781-8272
Fax: (801) 781-4888

VSL

RETAINED EARTH™ WALLS
WIRE FACED WALL "R-350-1"
TYPICAL CROSS SECTION

UTAH I-15 INTERCHANGE
SALT LAKE COUNTY, UTAH
UTAH DEPARTMENT OF TRANSP.

SCALE: 3.1R-350-1.7
JOB NO: 239-0007
RE-5

E:\PROJECT\239-0007\13SERIES\13-101\W13-

FINAL 10-06-97

APPROVED FOR CONSTRUCTION		
NO.	DATE	DESCRIPTION
△	10-06-97	RELEASE FOR 1ST STAGE CONST. ONLY

BEGIN WIRE FACED WALL R-350-1
 WIRE FACED WALL STA 5+000.000 =
 EN-NBCD STA 1+408.262
 @ 15.289 RT



WASATCH CONSTRUCTORS
 OCT 20 1997
 RELEASED FOR CONSTRUCTION

VSL CORPORATION
 2840 Plaza Place, Suite 200
 Raleigh, NC 27612
 Telephone: (919) 791-8272
 Fax: (919) 791-4889



VSL Corporation (USA) is a registered trademark of VSL. All other trademarks are the property of their respective owners. VSL is not responsible for any errors or omissions in this document. The use of this document is limited to the project for which it was prepared and for which it was specifically intended. No other use is permitted without the written consent of VSL.

RETAINED EARTH™ WALLS
 WALL "R-350-1" - 1ST STAGE: WIRE FACED WALL
 UTAH I-15 INTERCHANGE
 SALT LAKE COUNTY, UTAH
 UTAH DEPARTMENT OF TRANSP.

SCALE:	3.1R-350-1.8
JOB NO.:	239-0007
	RE-6

SHT 8 OF 9

BEGIN WALL

MATCH LINE #1

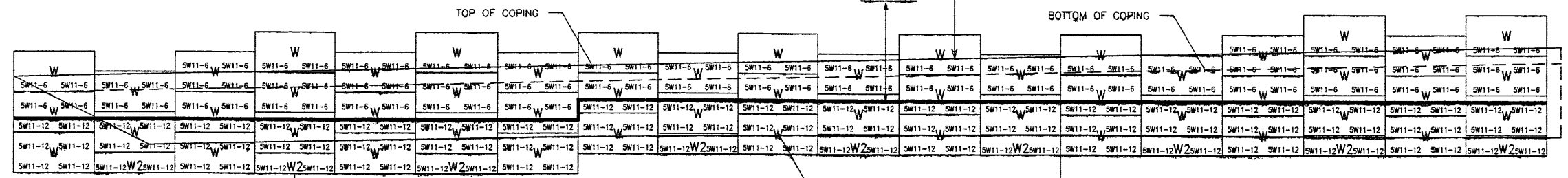

MESH DEPTH
 MAXIMUM BEARING PRESSURE
 (SEE NOTE BELOW)
 PIN SPACING

1	2	3	4	5	6	7	8	9	10	11	12	13	14	15	16	17	18	19
21.336										36.576								
3.658M										131 kPa								

RETAINING WALL "R-350-1" - 1ST STAGE: WIRE FACED WALL

(FRONT FACE SHOWN)
 (TOTAL SURFACE AREA OF FACING = 583.49 SM)
 SCALE 1:100 (FULL SIZE)
 SCALE 1:200 (HALF SIZE)

* INDICATES SOIL REINFORCING TYPE MESH TO BE USED ON ADDITIONAL WIRE WALL FACING ADDED AFTER SETTLEMENT.

METRIC

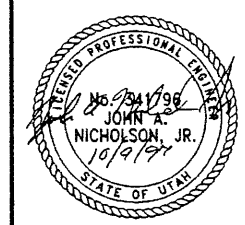

CERTIFIED FOR INTERNAL STABILITY OF RETAINED EARTH™ STRUCTURES ONLY. EXTERNAL STABILITY, INCLUDING BUT NOT LIMITED TO FOUNDATION AND SLOPE STABILITY, IS THE RESPONSIBILITY OF THE OWNER. DESIGN IS BASED ON THE ASSUMPTION THAT THE MATERIAL WITHIN THE RETAINED EARTH™ MASS, METHODS OF CONSTRUCTION, AND QUALITY OF PREFABRICATED MATERIALS CONFORM TO THE MANUFACTURER'S SPECIFICATION.

E:\PROJECT\239-0007\13SERIES\13-101\W13-1C
FINAL P. 0-06-97

APPROVED FOR CONSTRUCTION		
NO.	DATE	DESCRIPTION
1	10-06-97	RELEASE FOR 1ST STAGE CONST. ONLY

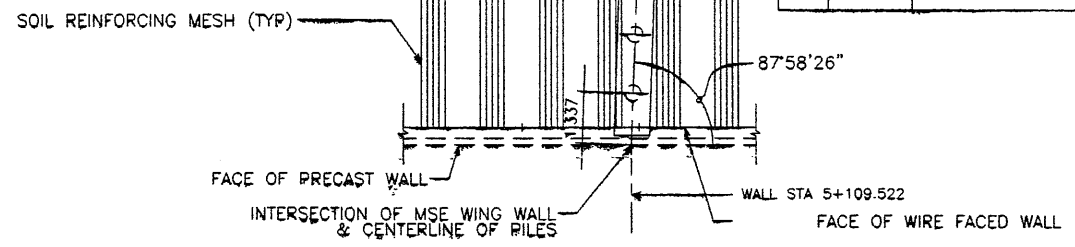

END WIRE FACED WALL R-350-1
WIRE FACED WALL STA 5+116.919 =
EN-NBCD STA 1+525.963
@ 15.289 RT

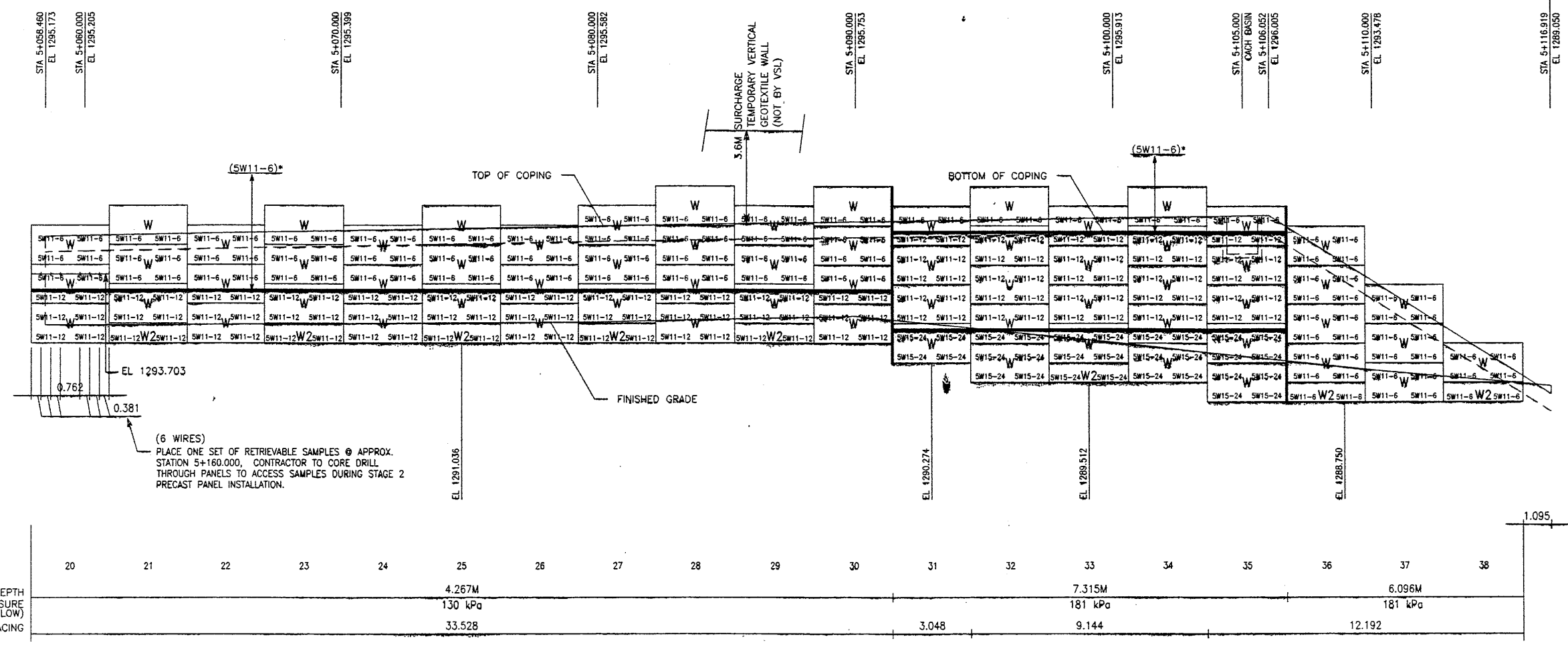

RETAINING WALL "R-350-1" - 1ST STAGE: WIRE FACED WALL
(FRONT FACE SHOWN)
(TOTAL SURFACE AREA OF FACING = 583.49 SM)
SCALE 1:100 (FULL SIZE)
SCALE 1:200 (HALF SIZE)

* INDICATES SOIL REINFORCING TYPE MESH TO BE USED ON ADDITIONAL WIRE WALL FACING ADDED AFTER SETTLEMENT.

CERTIFIED FOR INTERNAL STABILITY OF RETAINED EARTH™ STRUCTURES ONLY. EXTERNAL STABILITY, INCLUDING BUT NOT LIMITED TO FOUNDATION AND SLOPE STABILITY, IS THE RESPONSIBILITY OF THE OWNER. DESIGN IS BASED ON THE ASSUMPTION THAT THE MATERIAL WITHIN THE RETAINED EARTH™ MASS, METHODS OF CONSTRUCTION, AND QUALITY OF PREFABRICATED MATERIALS CONFORM TO THE MANUFACTURER'S SPECIFICATION.

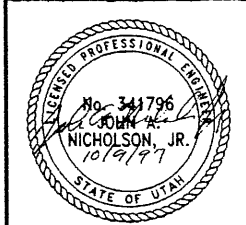

WATCH CONSTRUCTORS
OCT 20 1997
RELEASED FOR CONSTRUCTION

DES. 09-22-97 MM
DRN. 09-22-97 DDO
CHK. 09-22-97 MM

RETAINED EARTH™

VSL CORPORATION
2640 Pinedale Plaza, Suite 200
Raleigh, NC 27607 Tel: 919-872-7272
Fax: (919) 781-4889

UTAH DEPARTMENT OF TRANSPORTATION
SALT LAKE COUNTY, UTAH
RETAINED EARTH™ WALLS
WALL "R-350-1" - 1ST STAGE: WIRE FACED WALL
UTAH I-15 INTERCHANGE
SCALE: 3.1R-350-1.9
JOB NO: 239-0007
RE-7

SHT 9 OF 9

REFERENCE (X-UTAH.DWG)

APPROVED FOR CONSTRUCTION		
NO.	DATE	DESCRIPTION
▲	05-10-99	RELEASE FOR 2ND. STAGE CONSTRUCTION

BEGIN PRECAST WALL R-350-1
 PRECAST WALL STA 5+000.000 =
 EN-NBCD STA 1+408.283
 @ 15.608 RT

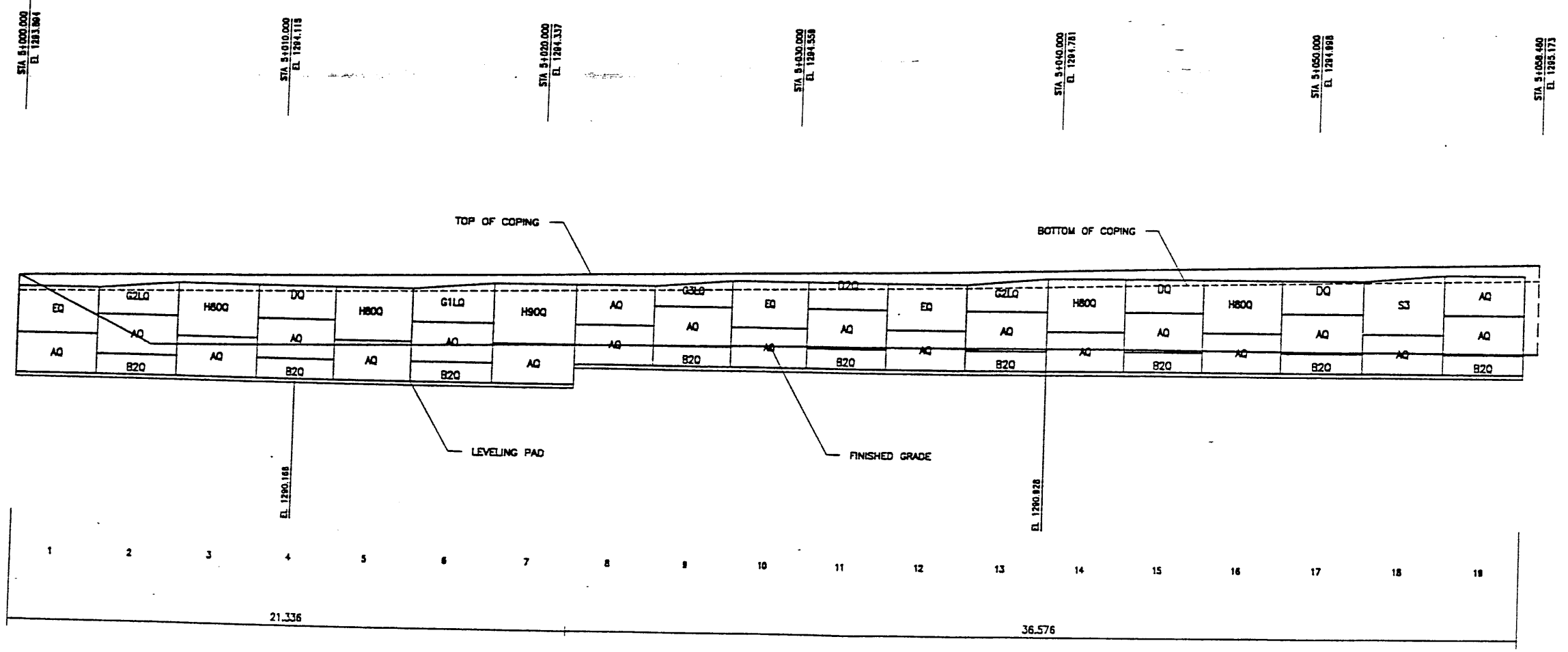

BEGIN WALL

MATCH LINE #1

RETAINING WALL "R-350-1" - 2ND. STAGE: PRECAST WALL
 (FRONT FACE SHOWN)
 (TOTAL SURFACE AREA OF FACING = 464.55 SM)
 SCALE 1:100 (FULL SIZE)
 SCALE 1:200 (HALF SIZE)

WASATCH CONSTRUCTORS
 JUN 17 1999
 RELEASED FOR CONSTRUCTION
 METRIC

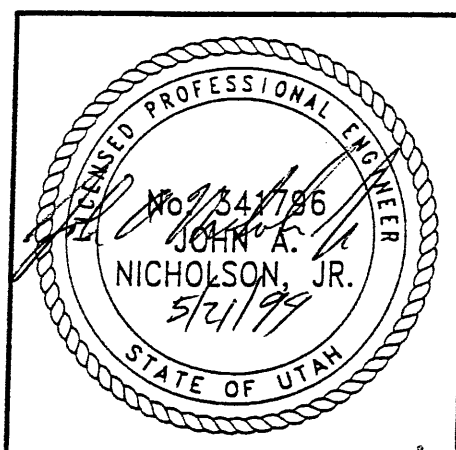

CERTIFIED FOR INTERNAL STABILITY OF RETAINED EARTH™ STRUCTURES ONLY. EXTERNAL STABILITY, INCLUDING BUT NOT LIMITED TO FOUNDATION AND SLOPE STABILITY, IS THE RESPONSIBILITY OF THE OWNER. DESIGN IS BASED ON THE ASSUMPTION THAT THE MATERIAL WITHIN THE RETAINED EARTH™ MASS, METHODS OF CONSTRUCTION, AND QUALITY OF PREFABRICATED MATERIALS CONFORM TO THE MANUFACTURER'S SPECIFICATION.

RFC After Final Approval

NO.	DATE	DESCRIPTION	BY

DES.	MM	NO.	DATE

DES.	MM	NO.	DATE

VSL CORPORATION
 2810 Pinta Place, Suite 200
 Raleigh, NC 27617
 Telephone: (919) 881-8772
 Fax: (919) 761-1989

VSL
 ATLANTA, GA / DALLAS, TX / WALDORF, MD (CORPORATE OFFICE)
 WASHINGTON, DC / SAN JOSE, CA / SPRINGFIELD, VA

VSL Corporation (VSL) shall retain all proprietary rights in the design and construction of the project. The design and construction of the project shall be in accordance with the specifications and standards of the State of Utah. The design and construction of the project shall be subject to the approval of the State of Utah. The design and construction of the project shall be subject to the approval of the State of Utah.

RETAINED EARTH™ WALLS
 WALL "R-350-1" - 2ND STAGE: PRECAST WALL
 UTAH I-15 INTERCHANGE
 SALT LAKE COUNTY, UTAH
 UTAH DEPARTMENT OF TRANSP.

DWG. NO.	3.1R-350-1.10
JOB NO.	239-0007
SHT. NO.	RE-8

C:\ASE-DWG\13SERIES\13-101-2-Stage\13-101
 FINAL PLOT 05-10-99
 ENCE (X-UTAH.DWG)

APPROVED FOR CONSTRUCTION		
NO.	DATE	DESCRIPTION
△	05-10-99	RELEASE FOR 2ND. STAGE CONSTRUCTION

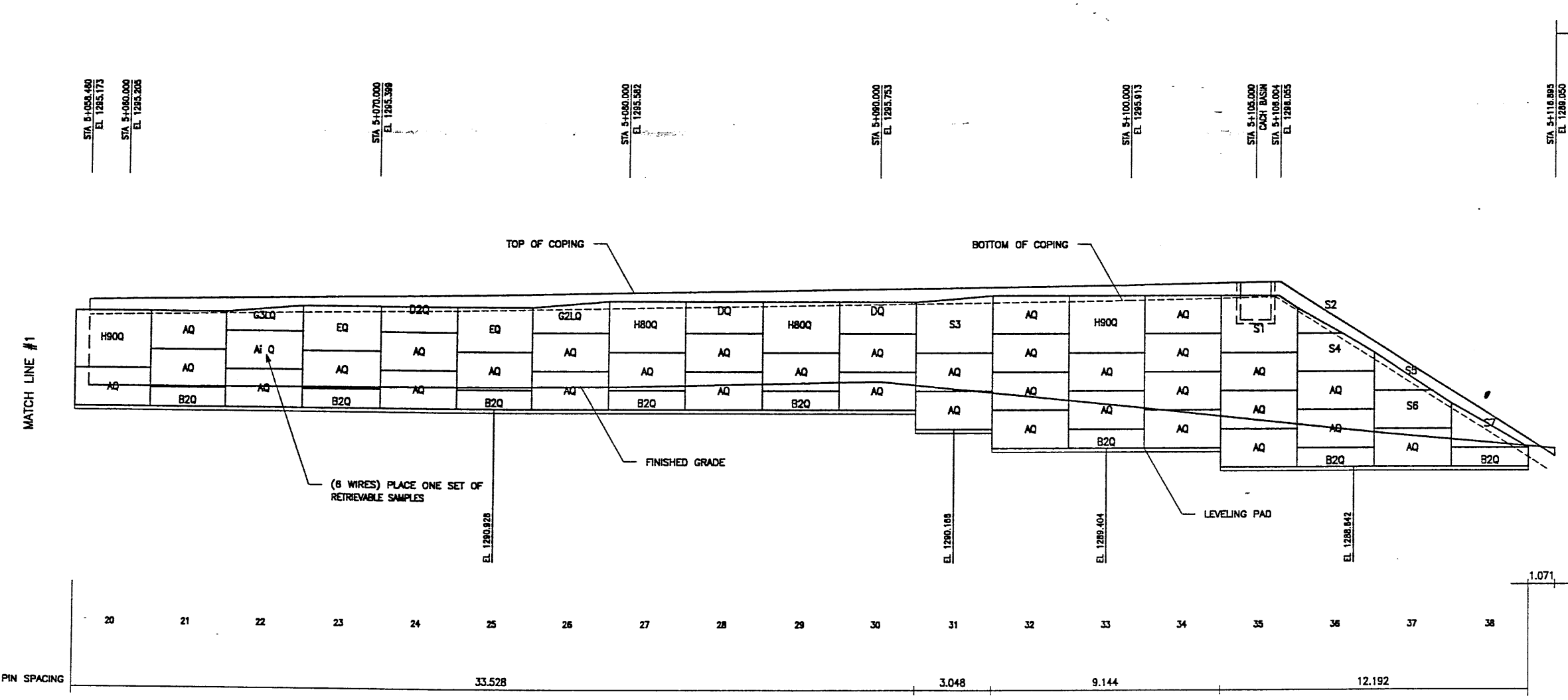

END PRECAST WALL R-350-1
 WIRE FACED WALL STA 5+116.895 -
 EN-NBCD STA 1+525.969
 ● 15.593 RT

DES.	MM	DRN.	DSW	CHK.	MM	NO.	DATE	REVISION	BY	CHK
	05-10-99		05-10-99		05-10-99					

VSL CORPORATION
 2840 Plaza Place, Suite 200
 Raleigh, NC 27612
 Telephone: (919) 781-8372
 Fax: (919) 781-0869

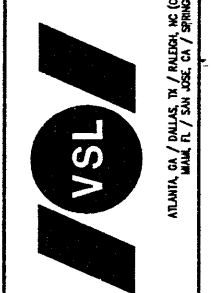

VSL Corporation (VSL) does a strict proprietary design and construction. Information is for reference only and is not to be used for any other project without the express written permission of VSL. VSL shall not be held liable for any errors or omissions in this drawing. VSL shall not be held liable for any damage or injury resulting from the use of this drawing. VSL shall not be held liable for any damage or injury resulting from the use of this drawing. VSL shall not be held liable for any damage or injury resulting from the use of this drawing.

RETAINING WALL "R-350-1" - 2ND. STAGE: PRECAST WALL
 (FRONT FACE SHOWN)
 (TOTAL SURFACE AREA OF FACING = 464.55 SM)
 SCALE 1:100 (FULL SIZE)
 SCALE 1:200 (HALF SIZE)

WASATCH CONSTRUCTORS
 JUN 17 1999
 RELEASED FOR CONSTRUCTION
 METRIC

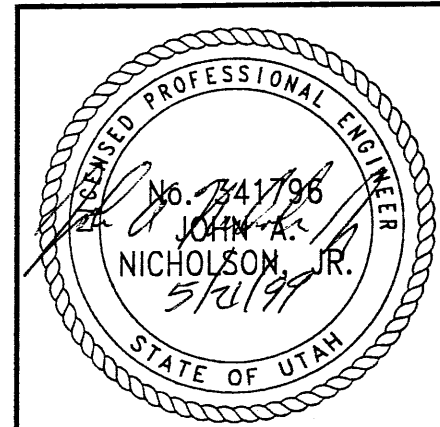

CERTIFIED FOR INTERNAL STABILITY OF RETAINED EARTH™ STRUCTURES ONLY. EXTERNAL STABILITY, INCLUDING BUT NOT LIMITED TO FOUNDATION AND SLOPE STABILITY, IS THE RESPONSIBILITY OF THE OWNER. DESIGN IS BASED ON THE ASSUMPTION THAT THE MATERIAL WITHIN THE RETAINED EARTH™ MASS, METHODS OF CONSTRUCTION, AND QUALITY OF PREFABRICATED MATERIALS CONFORM TO THE MANUFACTURER'S SPECIFICATION.

RETAINED EARTH™ WALLS
WALL "R-350-1" - 2ND STAGE: PRECAST WALL
UTAH I-15 INTERCHANGE
SALT LAKE COUNTY, UTAH
UTAH DEPARTMENT OF TRANSP.
DWG. NO. 3.1R-350-1.11
JOB NO. 239-0007
SIT. NO. RE-9

RFC After Final Approval

REFERENCE (X-UTAH.DWG)

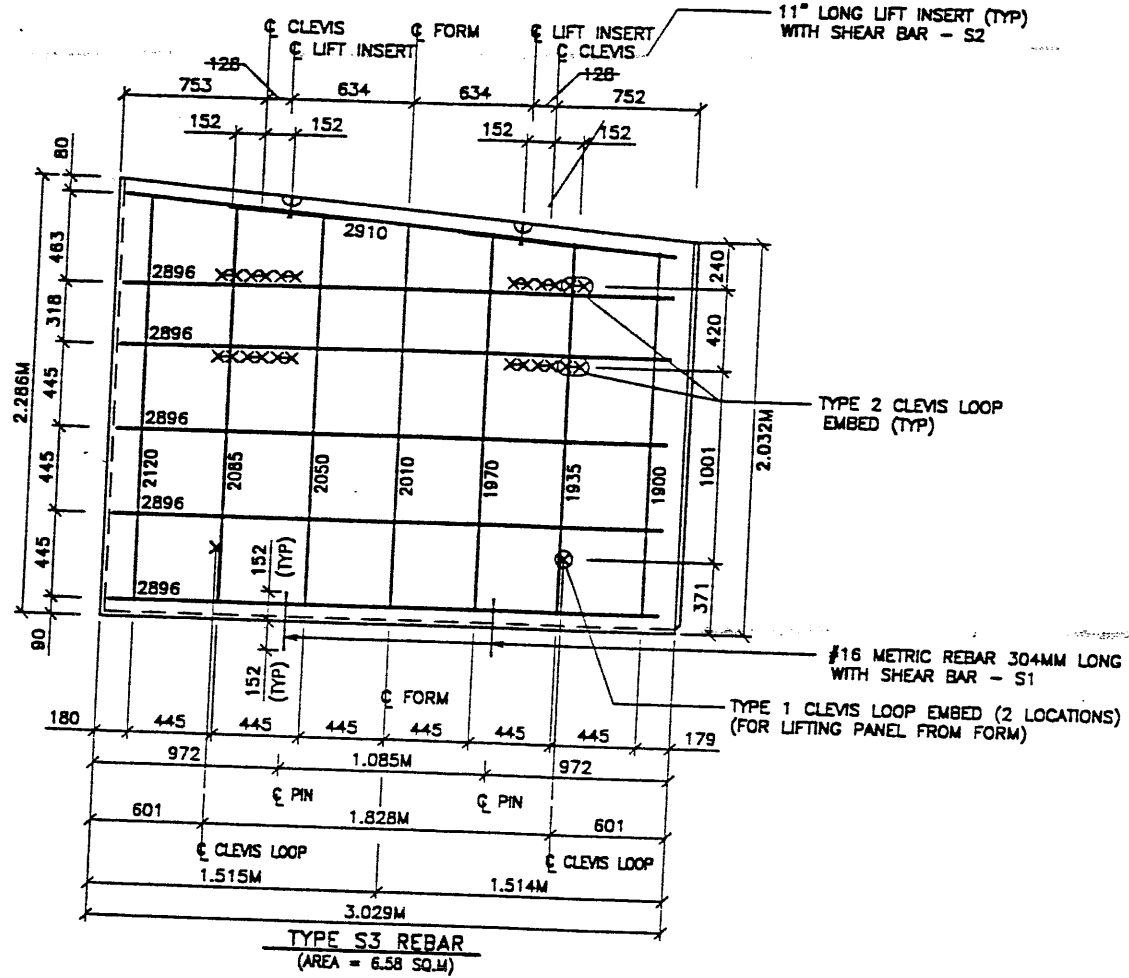

TYPE S3 REBAR
(AREA = 6.58 SQ.M)

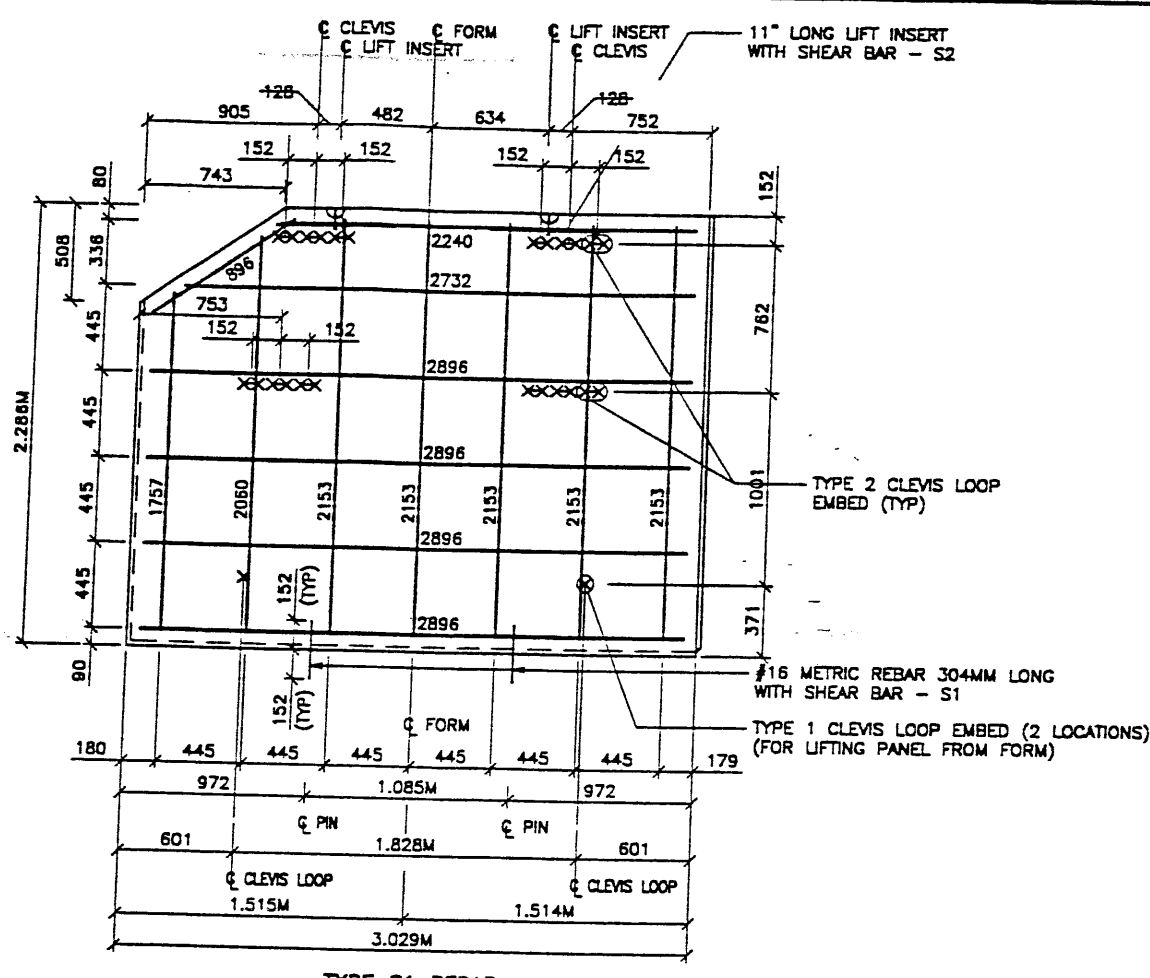

TYPE S1 REBAR
(AREA = 6.77 SQ.M)

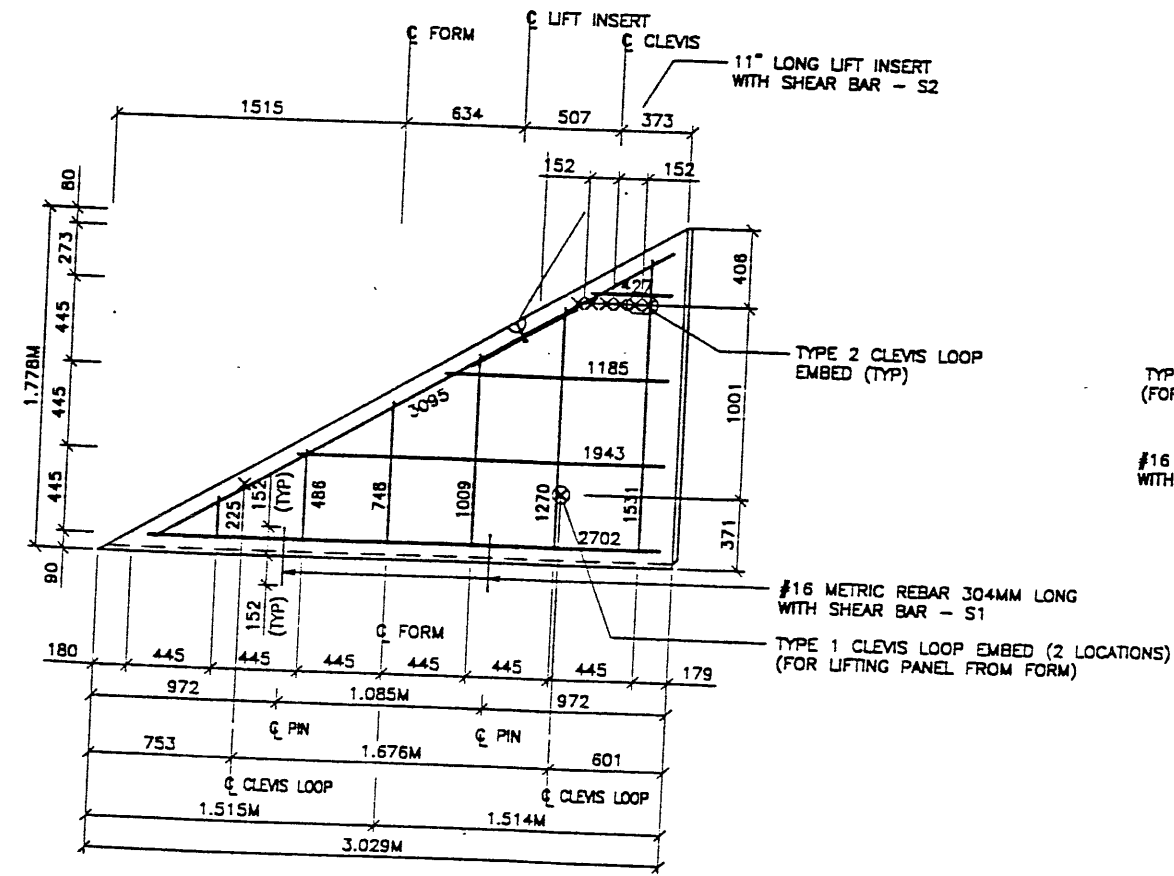

TYPE S7 REBAR
(AREA = 2.71 SQ.M)

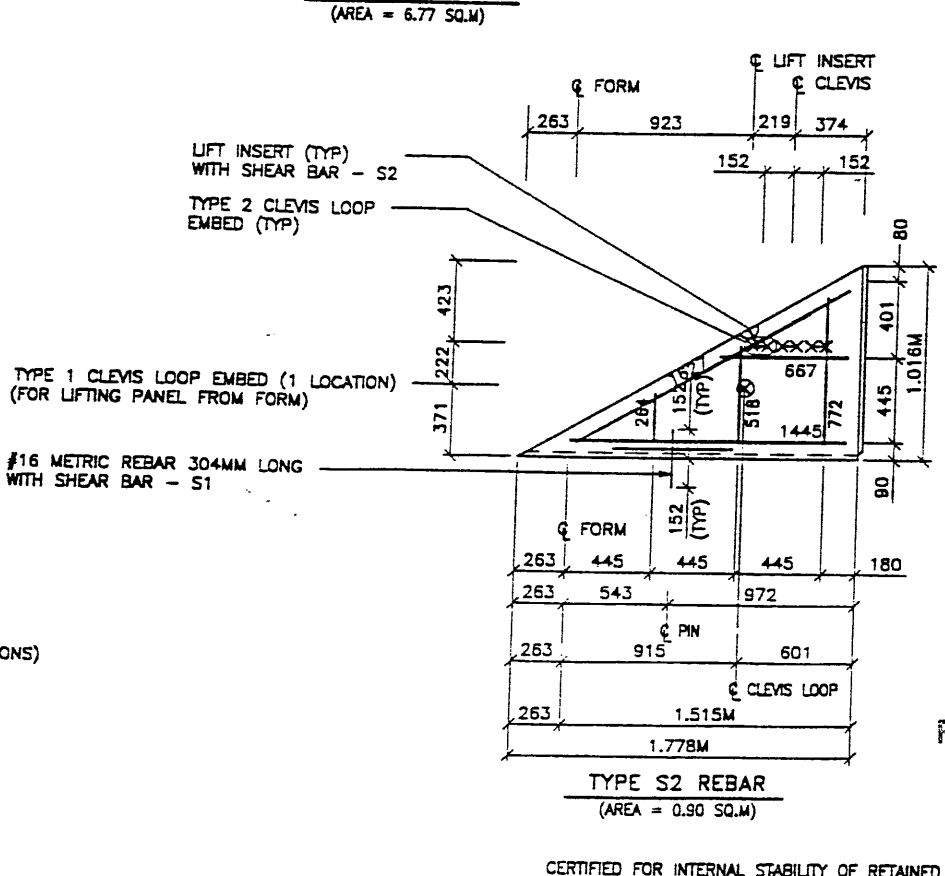

TYPE S2 REBAR
(AREA = 0.90 SQ.M)

APPROVED FOR CONSTRUCTION		
NO.	DATE	DESCRIPTION
1	05-10-99	RELEASE FOR 2ND STAGE CONSTRUCTION

- PANEL REINFORCEMENT NOTES:**
1. PANELS ARE SHOWN BACK FACE.
 2. HORIZONTAL REINFORCEMENT SHALL HAVE 50 mm MINIMUM COVER TO THE BACK FACE.
 3. ALL REINFORCEMENT SHALL HAVE 50 mm MINIMUM COVER TO THE SIDES.
 4. ALL REINFORCING BARS ARE #13 METRIC. LABELS ON EACH BAR INDICATE LENGTH. EXAMPLE: 1345 IS A #13 BAR 1345 mm LONG.
 5. PANEL REINFORCEMENT BARS SHALL BE DEFORMED BILLET STEEL BARS FOR CONCRETE REINFORCEMENT CONFORMING TO THE SPECIFICATIONS OF ASTM DESIGNATION A615, GRADE 60.
 6. ALL REINFORCING STEEL TO BE GALVANIZED IN ACCORDANCE WITH ASTM 767 CLASS I.
 7. CONCRETE PANELS TO HAVE 28 DAY COMPRESSIVE STRENGTH OF 25,200 KPa.
 8. EQUIVALENT WELDED WIRE FABRIC MAY BE USED.
 9. ALL PANELS TO USE 9.5mm WIDE CLEVIS LOOPS.
 10. VSL RETAINED EARTH IS PROTECTED UNDER PATENT 4,725,170.
 11. LIFT INSERTS ARE 6 3/4" LONG IN ALL PANELS LESS THAN 1.524M TALL. PANELS TALLER THAN 1.524M SHALL HAVE 11" LONG LIFT ANCHORS.
 12. SEE FOSTER GEOTECHNICAL STD. PLANS FOR ADD'L PANEL DETAILS.

NO.	DATE	DESCRIPTION	BY	CHK
1	05-10-99	RELEASE FOR 2ND STAGE CONSTRUCTION		

VSL CORPORATION
2810 Plaza Place, Suite 200
Raleigh, NC 27617
Telephone: (919) 81 6772
Fax: (919) 81 6989

VSL

ATLANTA, GA / DALLAS, TX / MIAMI, FL (CORPORATE OFFICE)
MEMPHIS, TN / SAN JOSE, CA / SPRINGFIELD, VA

WASATCH CONSTRUCTORS
JUN 17 1999
RELEASED FOR CONSTRUCTION

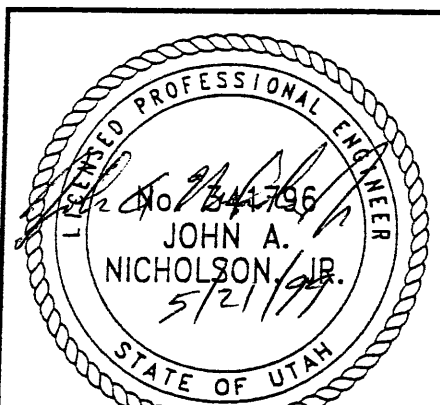

CERTIFIED FOR INTERNAL STABILITY OF RETAINED EARTH™ STRUCTURES ONLY. EXTERNAL STABILITY, INCLUDING BUT NOT LIMITED TO FOUNDATION AND SLOPE STABILITY, IS THE RESPONSIBILITY OF THE OWNER. DESIGN IS BASED ON THE ASSUMPTION THAT THE MATERIAL WITHIN THE RETAINED EARTH™ MASS, METHODS OF CONSTRUCTION, AND QUALITY OF PREFABRICATED MATERIALS CONFORM TO THE MANUFACTURER'S SPECIFICATION.

METRIC
RFC After Final Approval

RETAINED EARTH™ WALLS WALL "R-350-1" 2-STAGE PANEL REINFORCEMENT 600 NORTH / I-15 INTERCHANGE SALT LAKE COUNTY, UTAH UTAH DEPARTMENT OF TRANSP.
DWG. NO. 3.1R-R350-1.12
JOB NO. 239-0007
SHT. NO. RE-10

TERENCE (X-UTAWDNG)

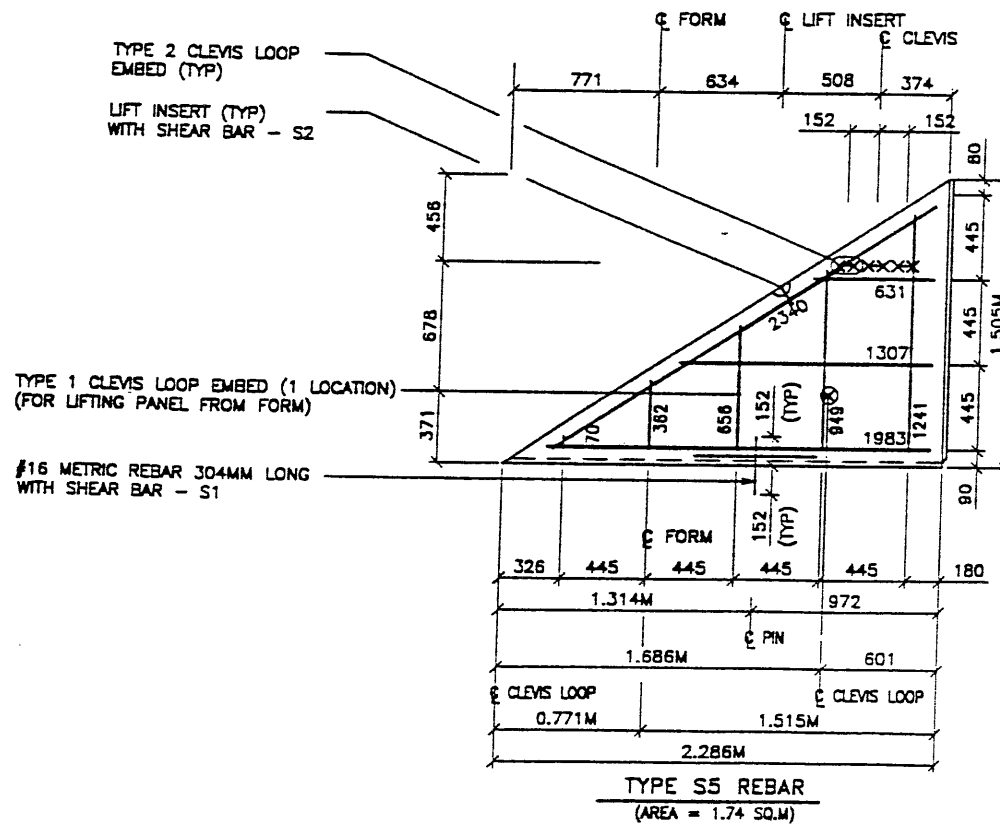
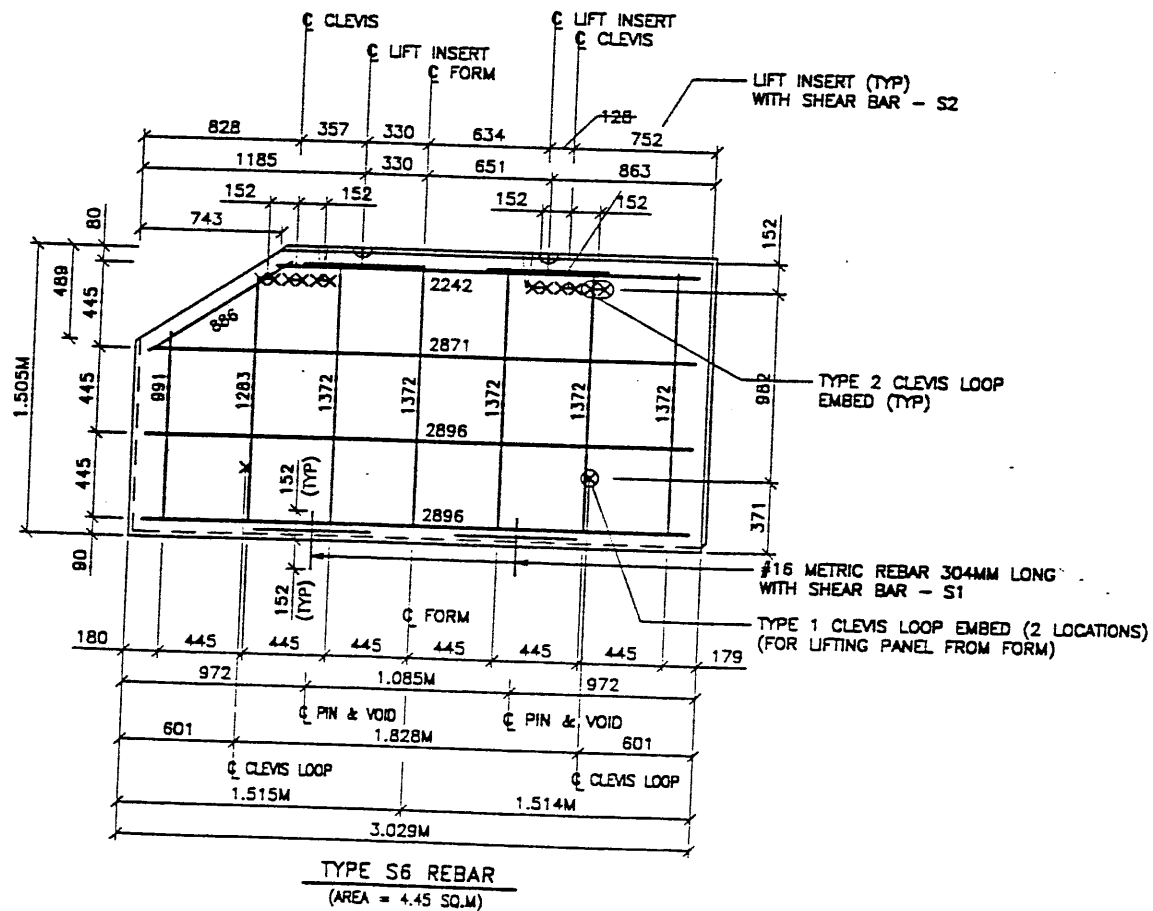
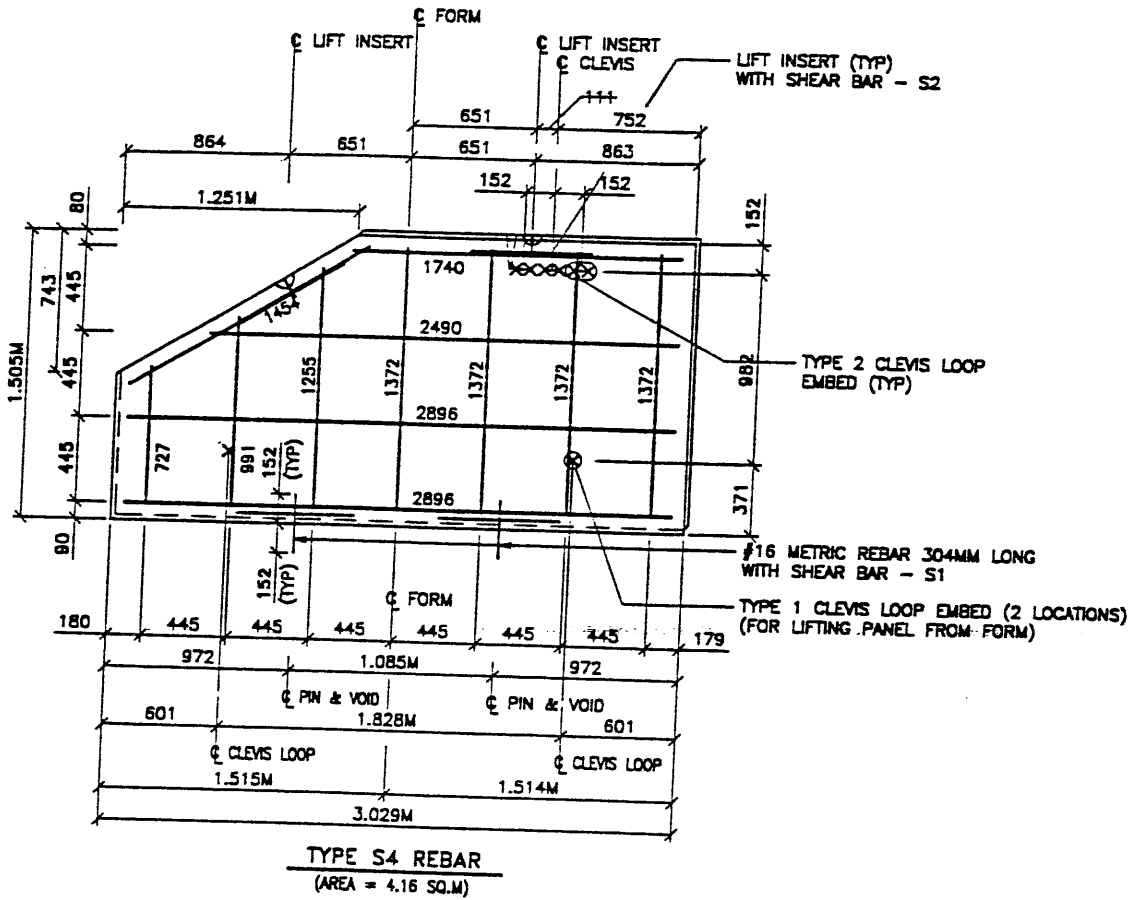

METRIC

CERTIFIED FOR INTERNAL STABILITY OF RETAINED EARTH™ STRUCTURES ONLY. EXTERNAL STABILITY, INCLUDING BUT NOT LIMITED TO FOUNDATION AND SLOPE STABILITY, IS THE RESPONSIBILITY OF THE OWNER. DESIGN IS BASED ON THE ASSUMPTION THAT THE MATERIAL WITHIN THE RETAINED EARTH™ MASS, METHODS OF CONSTRUCTION, AND QUALITY OF PREFABRICATED MATERIALS CONFORM TO THE MANUFACTURER'S SPECIFICATION.

APPROVED FOR CONSTRUCTION			
NO.	DATE	DESCRIPTION	BY
△	05-10-99	RELEASE FOR 2ND STAGE CONSTRUCTION	

- PANEL REINFORCEMENT NOTES:**
- PANELS ARE SHOWN BACK FACE.
 - HORIZONTAL REINFORCEMENT SHALL HAVE 50 mm MINIMUM COVER TO THE BACK FACE.
 - ALL REINFORCEMENT SHALL HAVE 50 mm MINIMUM COVER TO THE SIDES.
 - ALL REINFORCING BARS ARE #13 METRIC. LABELS ON EACH BAR INDICATE LENGTH. EXAMPLE: 1345 IS A #13 BAR 1345 mm LONG.
 - PANEL REINFORCEMENT BARS SHALL BE DEFORMED BILLET STEEL BARS FOR CONCRETE REINFORCEMENT CONFORMING TO THE SPECIFICATIONS OF ASTM DESIGNATION A615, GRADE 60.
 - ALL REINFORCING STEEL TO BE GALVANIZED IN ACCORDANCE WITH ASTM 767 CLASS I.
 - CONCRETE PANELS TO HAVE 28 DAY COMPRESSIVE STRENGTH OF 25,200 KPa.
 - EQUVALENT WELDED WIRE FABRIC MAY BE USED.
 - ALL PANELS TO USE 9.5mm WIDE CLEVIS LOOPS.
 - VSL RETAINED EARTH™ IS PROTECTED UNDER PATENT 4,725,170.
 - LIFT INSERTS ARE 6 3/4" LONG IN ALL PANELS LESS THAN 1.524M TALL. PANELS TALLER THAN 1.524M SHALL HAVE 11" LONG LIFT ANCHORS.
 - SEE FOSTER GEOTECHNICAL STD. PLANS FOR ADD'L PANEL DETAILS.

VSL CORPORATION
2810 Peachtree Street, Suite 200
Atlanta, GA 30328
Tel: (404) 521-6377
Fax: (404) 521-6069



ATLANTA, GA / DALLAS, TX / HALLOW, NC (CORPORATE OFFICE)
MILWAUKEE, WI / SAN JOSE, CA / SHANGHAI, CHINA

WASATCH CONSTRUCTORS
JUN 17 1999
RELEASED FOR CONSTRUCTION

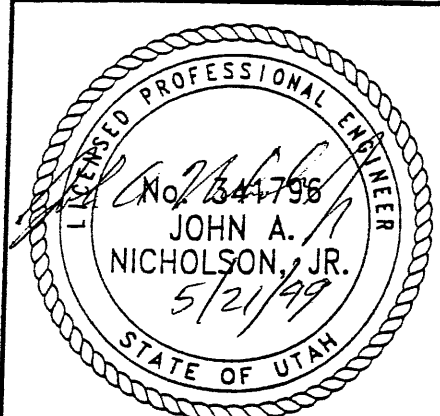

RETAINED EARTH™ WALLS
WALL "R-350-1"
2-STAGE PANEL REINFORCEMENT
600 NORTH / I-15 INTERCHANGE
SALT LAKE COUNTY, UTAH
UTAH DEPARTMENT OF TRANSP.

DWG. NO.	3.1R-350-1.13
JOB NO.	239-0007
SHT. NO.	RE-11

RFC After Final Approval

Username: wsl
Date: 07-MAR-2000 10:51:02

Filename: c:\dgn\15_cadd\13_37\sheet_files\wsl\13_r_etw\02_01.rvt

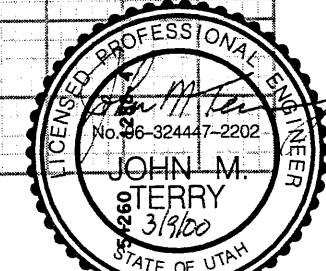
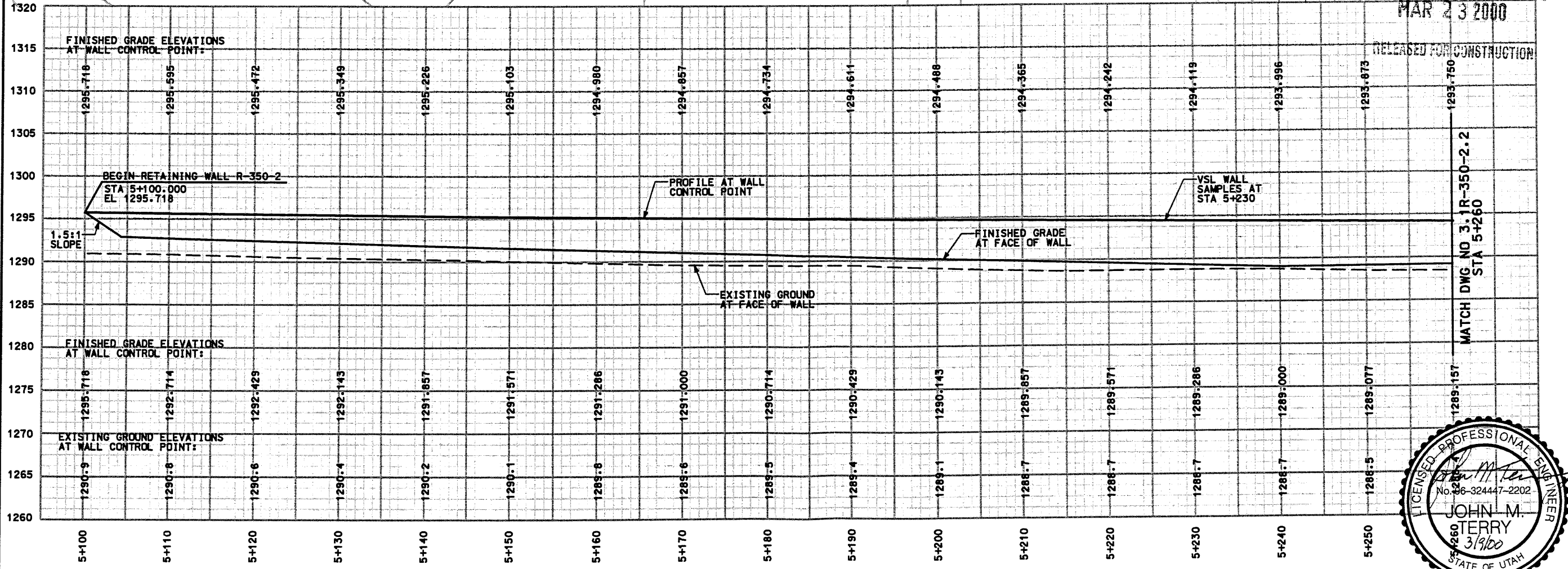
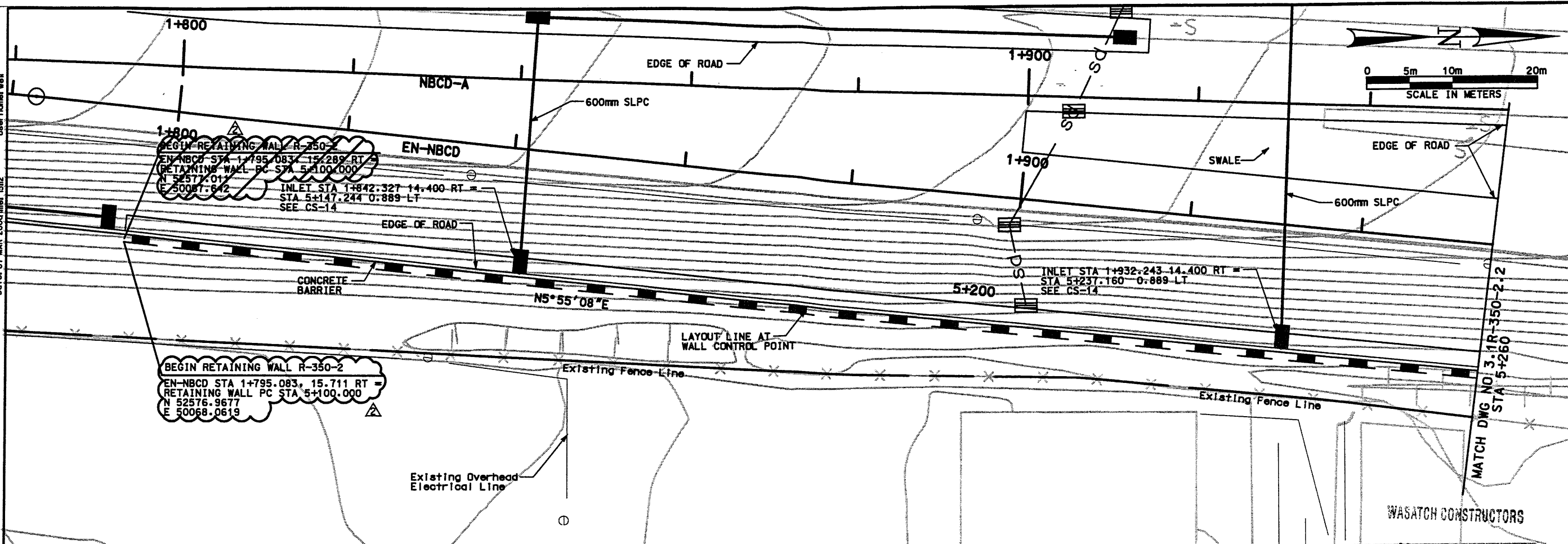

SEALED FOR THE NO. OF RELEASE ONLY

APPROVED FOR CONSTRUCTION		DESCRIPTION	
NO.	DATE	DATE	DESCRIPTION
Δ	4/13/98		ORIGINAL ISSUE
Δ	03/08/00		RELEASE FOR USE WALL AND STAGE CONSTRUCTION
Δ	/ /	/ /	
Δ	/ /	/ /	

UTAH DEPARTMENT OF TRANSPORTATION			
MK CENTENNIAL			
SVERDRUP/DE LEUW			
DESIGN	CHK	CJO	9/17/97
DRAW	MMW	7/31/97	
PROJECT DESIGN ENGINEER	DATE	PROJECT DESIGN ENGINEER	DATE
Bret A. Reynolds	9/17/97	Randle L. Ross	9/17/97
PROJECT MANAGER	DATE	PROJECT MANAGER	DATE

I-15 CORRIDOR RECONSTRUCTION		SITUATION & LAYOUT R-350-2	
SECTION 3.1		SECTION 3.1	
#SP-15-7(135)296		PROJECT NUMBER	
SALT LAKE COUNTY		COUNTY	
3.1R-350-2.1		DWG. NO.	
1 OF 10		SHT.	

Users: nmc:mll/wcm/v

Date: 13-APR-1998 Time: 10:32

Filename: P:\15_corr\15_corr\15_97\released_files\wall\3_1R-350-2.dwg

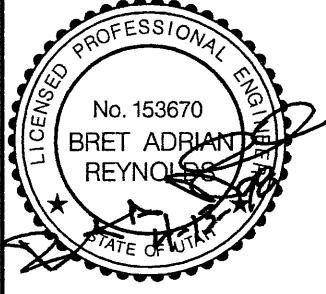
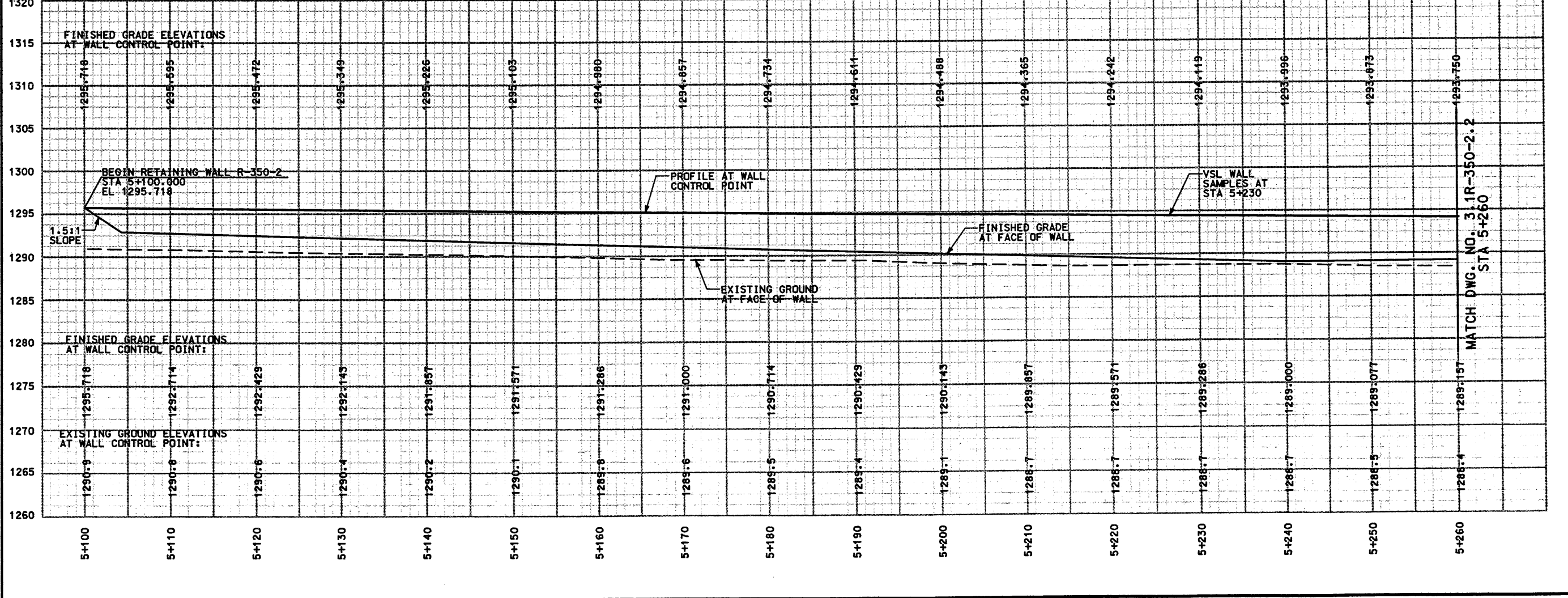
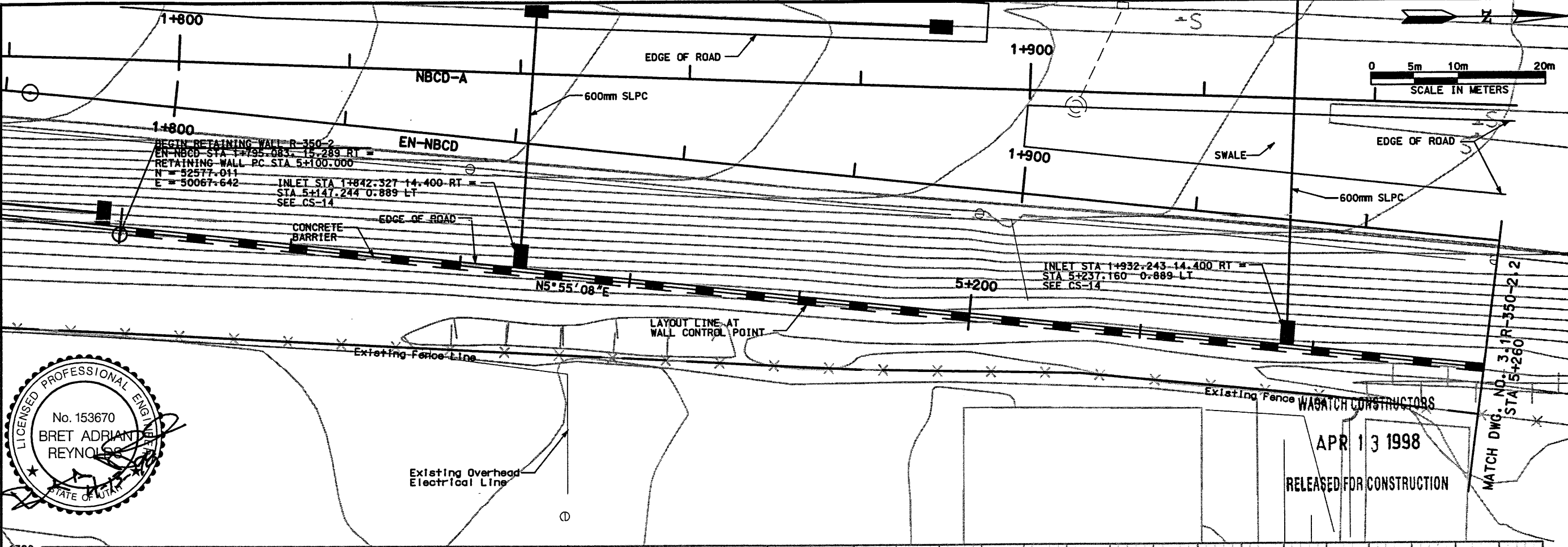

WABATCH CONSTRUCTORS
APR 13 1998
RELEASED FOR CONSTRUCTION

MATCH DWG. NO. 3.1R-350-2.2
STA 5+260

APPROVED FOR CONSTRUCTION		DESCRIPTION	
NO.	DATE	NO.	DATE
Δ	4/13/98	Δ	4/13/98
Δ	/ /	Δ	/ /
Δ	/ /	Δ	/ /
UTAH DEPARTMENT OF TRANSPORTATION		WBS NO. 8112407	
MK CENTENNIAL		CHECK CJO 9/17/97	
SVERDRUP/DE LEUW		CHECK CJO 9/17/97	
DESIGN DMC 7/29/97		CHECK CJO 9/17/97	
DRAWN MVM 7/31/97		CHECK CJO 9/17/97	
PROJECT DESIGN ENGINEER		CHECK	
DATE 9/17/97		PROJECT MANAGER	
Bret A. Reynolds		Randle L. Rogge	
PROJECT NUMBER #SP-15-7(135)296		QUANT.	
I-15 CORRIDOR RECONSTRUCTION		SALT LAKE COUNTY	
SITUATION & LAYOUT R-350-2		DWG. NO. 3.1R-350-2.1	
SECTION 3.1		SHT. 1 OF 10	
REF.			

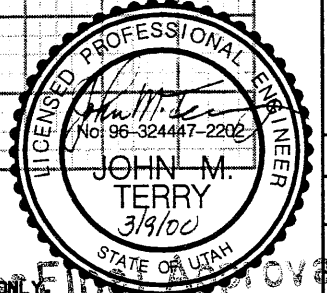
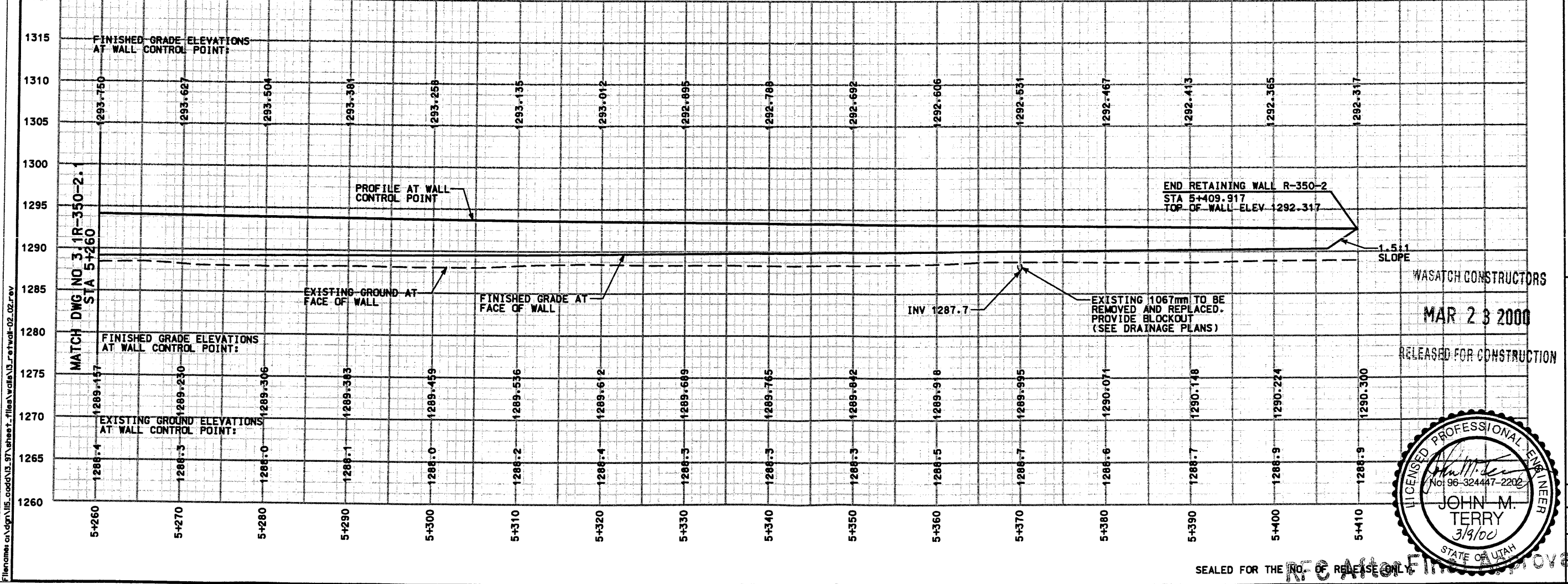
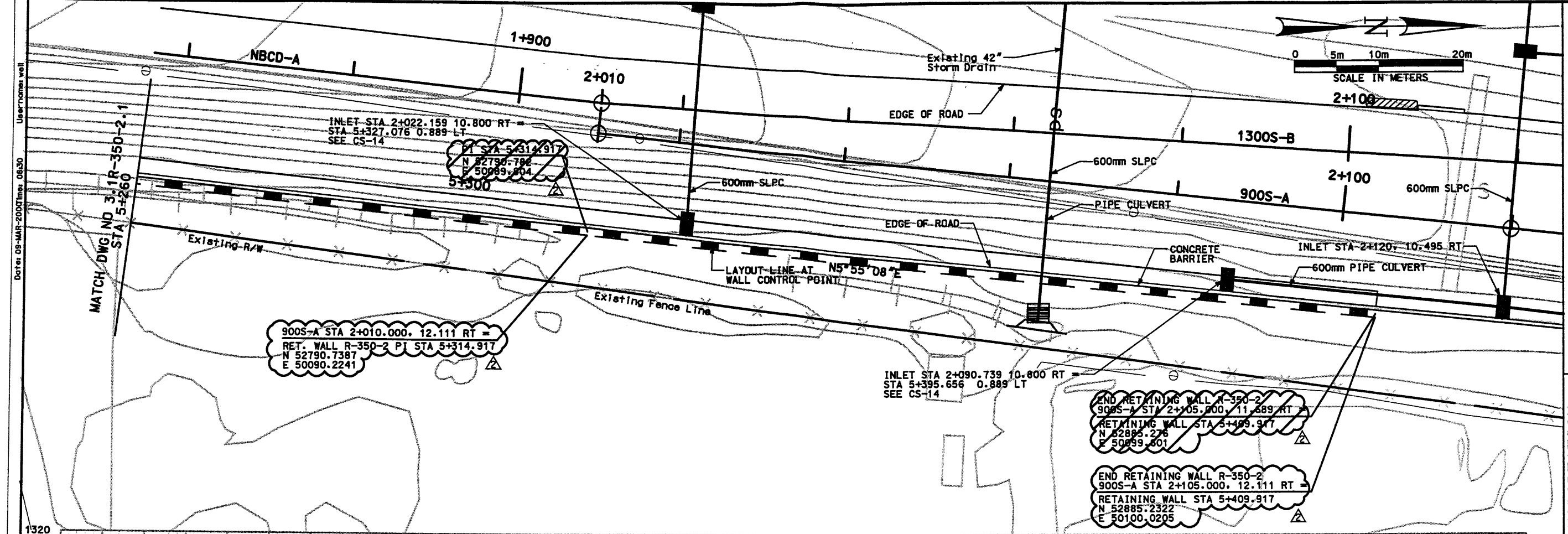

APPROVED FOR CONSTRUCTION		NO.	DATE	DESCRIPTION
△	4/13/98	△	03/08/00	ORIGINAL ISSUE
△	9/17/97	△	9/17/97	RELEASE FOR USE WALL 2ND STAGE CONSTRUCTION
△	9/17/97	△	9/17/97	RELEASE FOR USE WALL 2ND STAGE CONSTRUCTION
△	9/17/97	△	9/17/97	RELEASE FOR USE WALL 2ND STAGE CONSTRUCTION
UTAH DEPARTMENT OF TRANSPORTATION MK CENTENNIAL SVERDRUP/DE LEUW		DESIGN DMC	7/29/97	CHECK CJD
1-15 CORRIDOR RECONSTRUCTION SITUATION & LAYOUT R-350-2		DRAWN MVM	7/31/97	CHECK CJD
SECTION 3.1		PROJECT DESIGN ENGINEER	DATE	CHECK
PROJECT NUMBER #SP-15-711351296		Bret A. Reynolds	9/17/97	9/17/97
SALT LAKE COUNTY		Randle L. Robb	9/17/97	9/17/97
DWG. NO. 3.1R-350-2.2		PROJECT MANAGER	DATE	QUANT.
SHEET 2 OF 10		WBS NO.	3112407	

SEALED FOR THE RECORD OF RELEASE ONLY

Filename: P:\15_cadd\15_cadd\15_97\released_files\walls\3_wal-02.dgn

Date: 15-APR-1998 Time: 11:32

User: ramesh.milamany

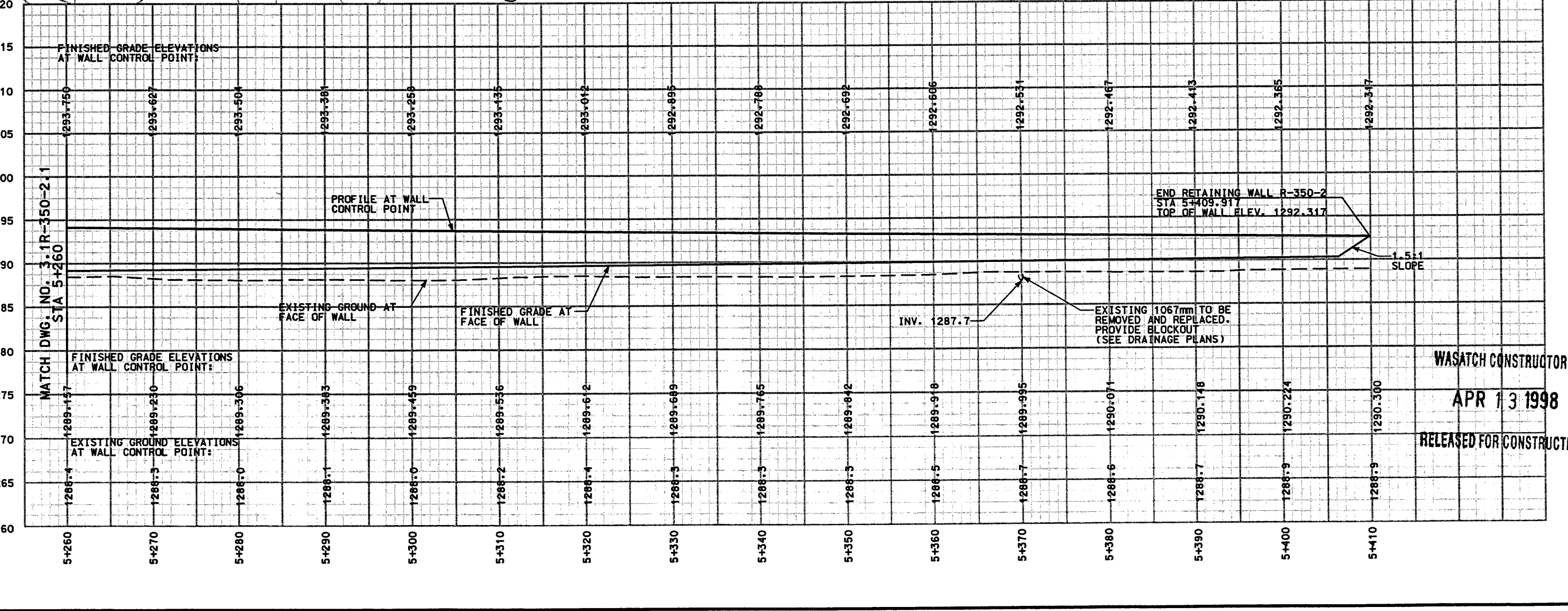
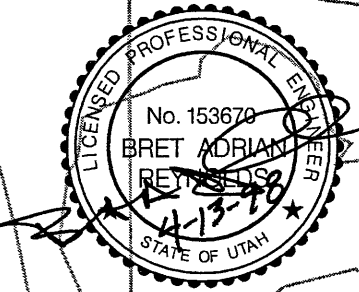
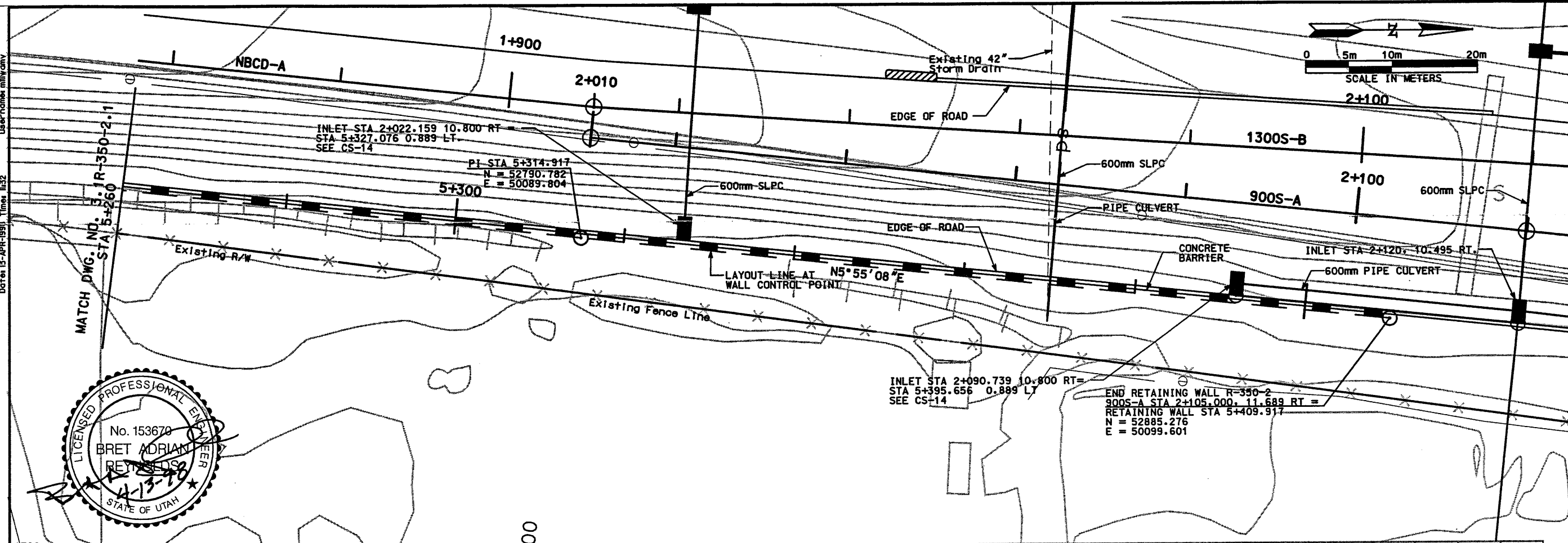

WASATCH CONSTRUCTORS
APR 13 1998
RELEASED FOR CONSTRUCTION

APPROVED FOR CONSTRUCTION	
NO.	DATE
△	4/13/98
△	/ /
△	/ /
△	/ /
DESCRIPTION	
ORIGINAL ISSUE	
WBS NO. 3112407	
CHECK CJO 9/17/97	
CHECK CJO 9/17/97	
CHECK CJO 9/17/97	
CHECK CJO 9/17/97	
PROJECT NUMBER	
#SP-15-7(135)296	
SECTION 3-1	
SITUATION & LAYOUT R-350-2	
I-15 CORRIDOR RECONSTRUCTION	
SALT LAKE COUNTY	
DWG. NO. 3.1R-350-2.2	
SHT 2 OF 10	
REF.	

UTAH DEPARTMENT OF TRANSPORTATION
MK OBERNENTHAL
SVERDRUP/DE LEUW

APPROVAL DATE 9/17/97
DESIGN DMC 7/29/97
DRAWN MWM 7/31/97
PROJECT DESIGN ENGINEER Raitle L. Rogff
PROJECT MANAGER

Usernames wall

Date: 07-MAR-2000 Time: 16:28

RETAINING WALL DETAIL WALL R-350-2 (2-STAGE MSE WALL)

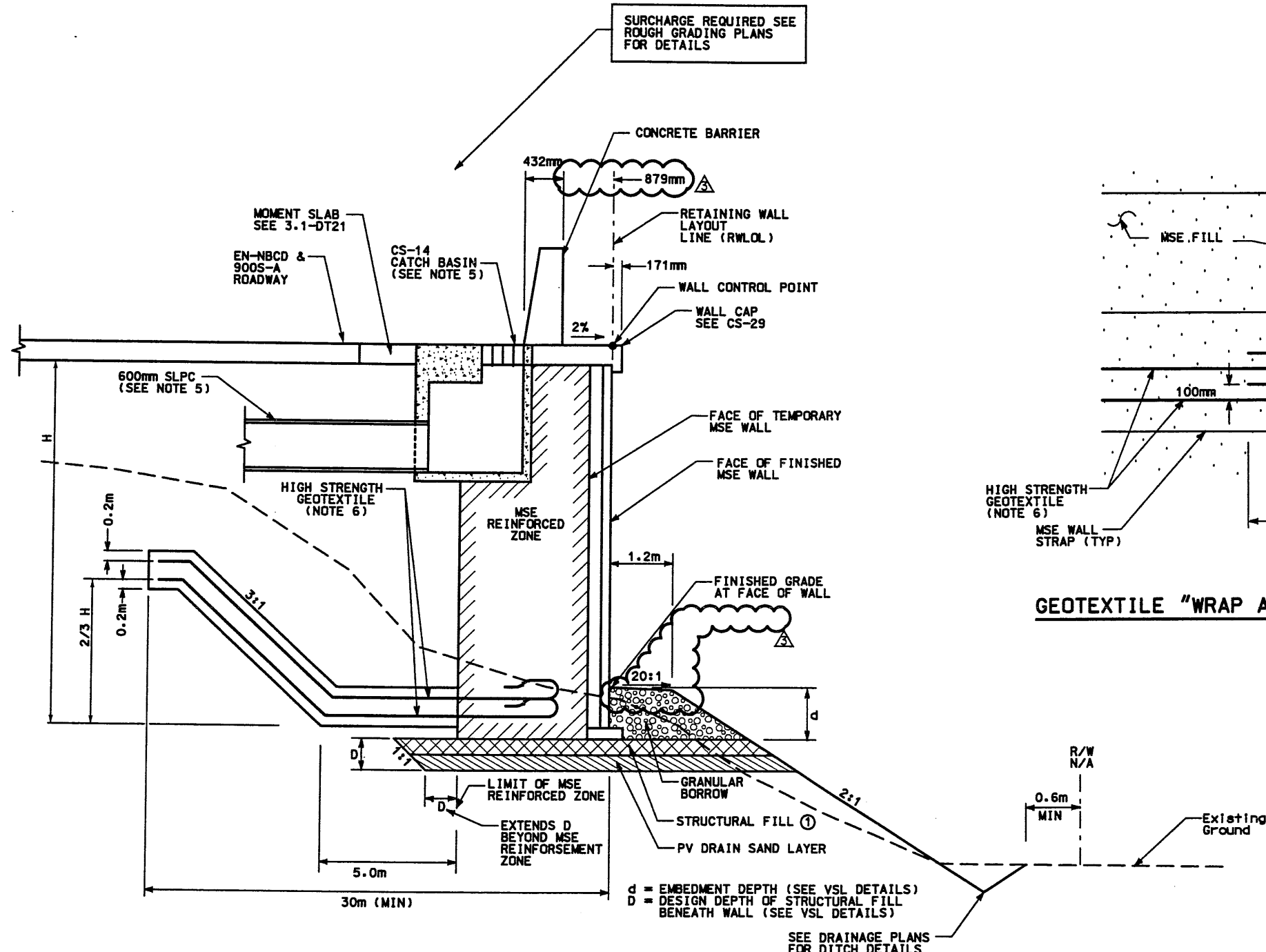

DETAIL A
STA 5+100 TO STA 5+210

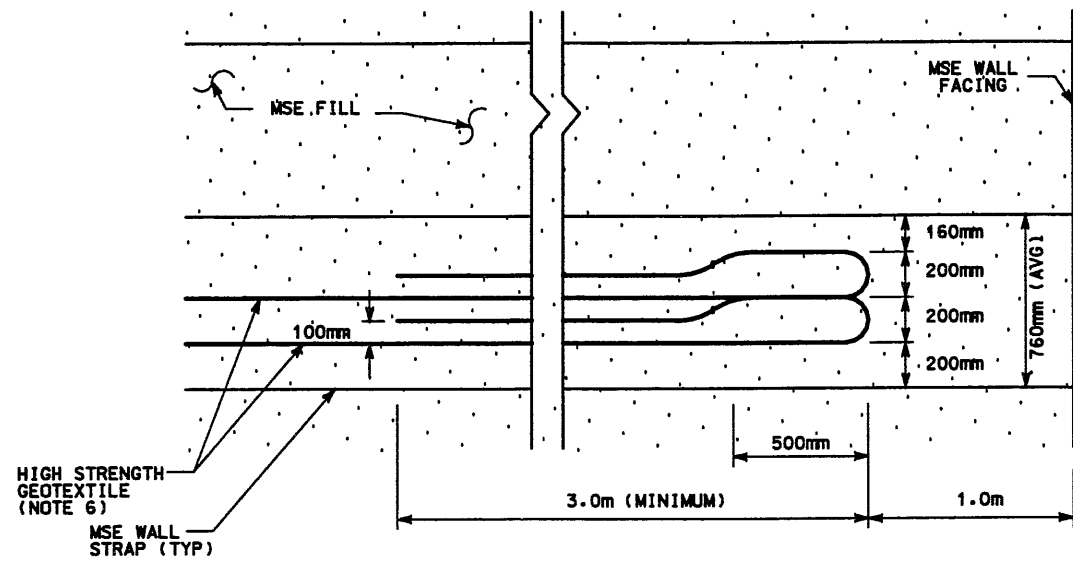

GEOTEXTILE "WRAP AROUND" ANCHORAGE WITHIN MSE WALL

NOTES:

- 1) OVEREXCAVATE EXISTING SOILS TO DEPTH (D) OF 1.0m MINIMUM OR AS SHOWN ON VSL PLANS.
- 2) SEE CORRIDOR STANDARD SPECIFICATION 221 FOR SPECIAL EXCAVATION REQUIREMENTS WHERE GROUNDWATER IS EXPECTED AT OR ABOVE THE REQUIRED EXCAVATION ELEVATION.
- 3) SEE CORRIDOR STANDARD SPECIFICATION 210 FOR SPECIAL EXCAVATION AND BACKFILL REQUIREMENTS WHERE SOFT CLAYS OR OTHER SOFT AND/OR WET CONDITIONS ARE ENCOUNTERED.
- 4) FOR INFORMATION ONLY, EXISTING STORM DRAIN PLACEMENT WILL NOT HAPPEN DURING CONSTRUCTION OF WALL R-350-2. SEE DRAINAGE PLANS AND PROFILES FOR ELEVATIONS AND LOCATIONS.
- 5) SEE ROUGH GRADING PLANS AND DETAILS FOR ADDITIONAL INFORMATION REGARDING PLACEMENT OF GEOTEXTILE OUTSIDE OF MSE WALL REINFORCEMENT ZONE.

WASATCH CONSTRUCTORS
MAR 23 2000
RELEASED FOR CONSTRUCTION



SEALED FOR THE NO. OF RELEASE ONLY.

APPROVED FOR CONSTRUCTION		DESCRIPTION	
NO.	DATE	ORIGINAL ISSUE	
▲	4/13/98	INC - 0274	
▲	10/26/98	RELEASE FOR MSE WALL 2ND STAGE CONSTRUCTION	
▲	03/08/00		
UTAH DEPARTMENT OF TRANSPORTATION		WBS NO. 3112407	
MK CENTENNIAL SVERDRUP/DE LEUW		DESIGN DMC 7/29/97	CHECK CJD 8/04/97
Bret A. Reynolds	PROJECT DESIGN ENGINEER	DRAWN MVM 7/29/97	CHECK CJD 8/04/97
8/04/97	DATE	Randle L. Robb	PROJECT MANAGER
8/04/97	DATE		
1-15 CORRIDOR RECONSTRUCTION		SECTION 3J	
WALL DETAIL R-350-2		#SP-15-711351296	
SALT LAKE COUNTY		DWG. NO. 3.1R-350-2.3	
SHT. 3	OF 10	REF.	

Final Approval

Users: names: webb/jb

Filename: c:\p\115\ood\13_97\sheet1_files\wall13_r_et\wall_02_03.dgn

RETAINING WALL DETAIL

WALL R-350-2
(2-STAGE MSE WALL)

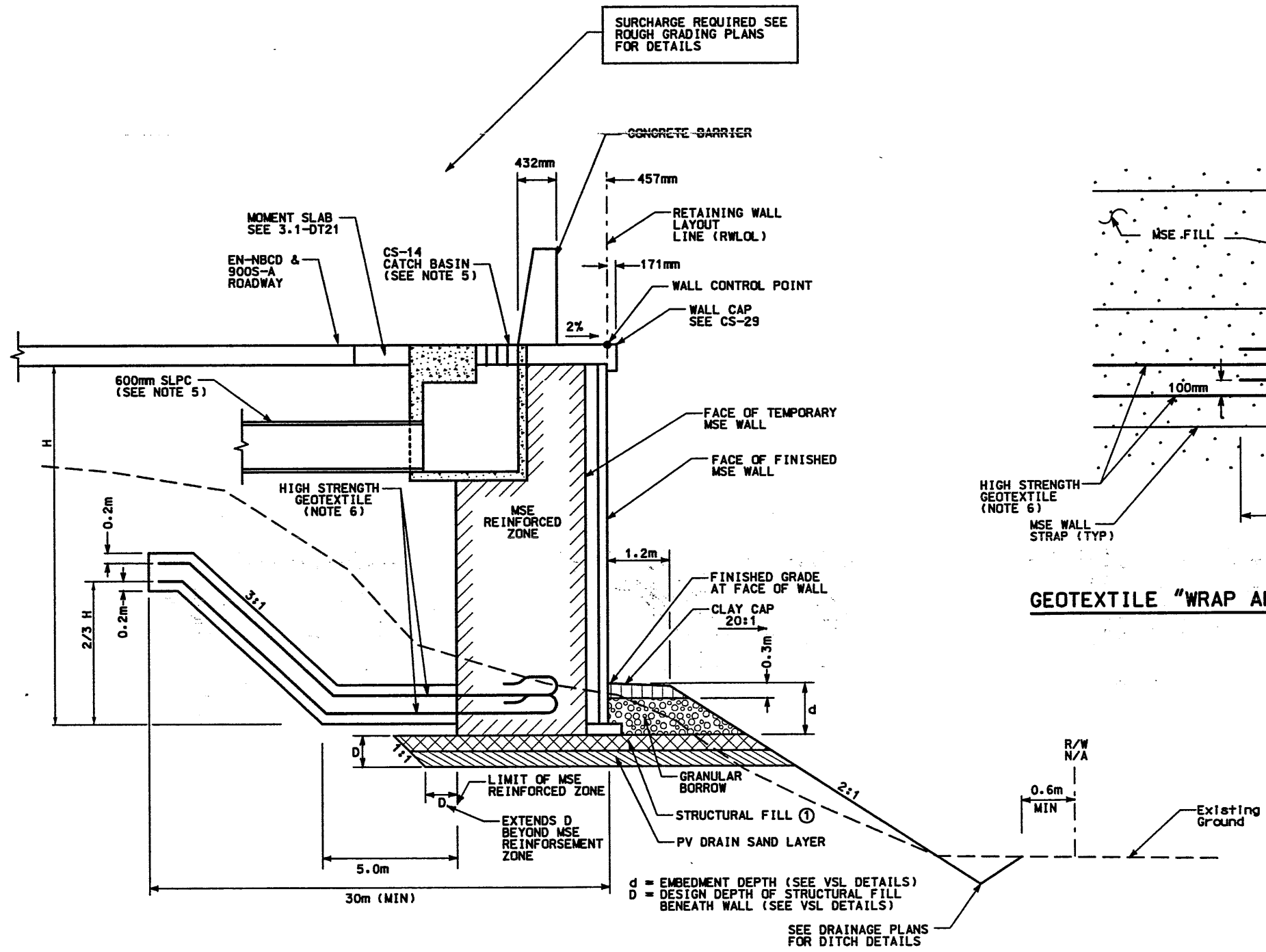

DETAIL A
STA 5+100 TO STA 5+210

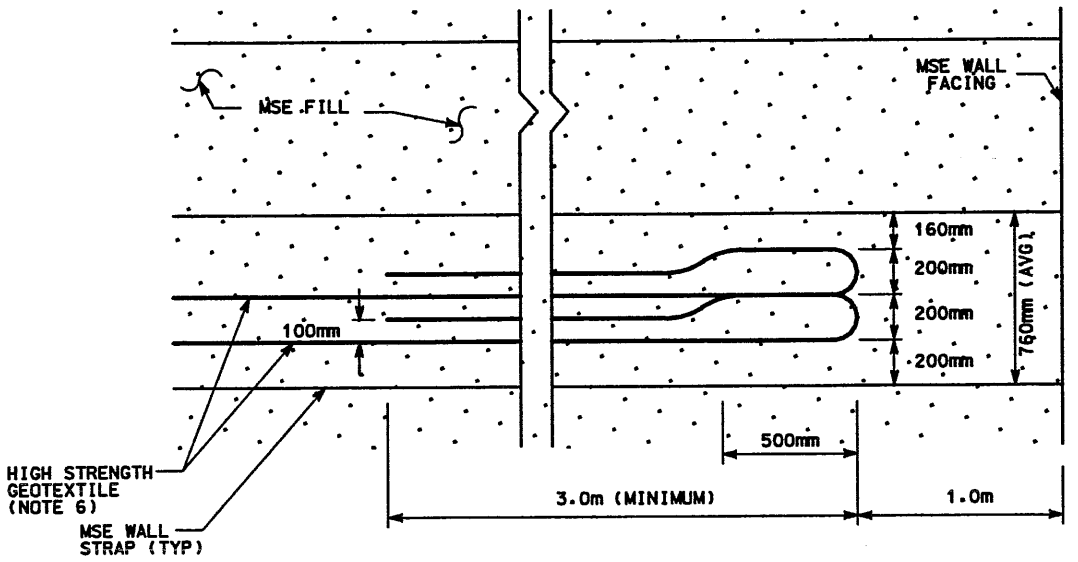

GEOTEXTILE "WRAP AROUND" ANCHORAGE WITHIN MSE WALL

WASATCH CONSTRUCTORS
NOV 02 1998
RELEASED FOR CONSTRUCTION

- NOTES:
- 1) OVEREXCAVATE EXISTING SOILS TO DEPTH (D) OF 1.0m MINIMUM OR AS SHOWN ON VSL PLANS.
 - 2) CONSTRUCT CLAY CAP WITH LOW PLASTIC SILTY CLAY (0.3m THICK).
 - 3) SEE CORRIDOR STANDARD SPECIFICATION 221 FOR SPECIAL EXCAVATION REQUIREMENTS WHERE GROUNDWATER IS EXPECTED AT OR ABOVE THE REQUIRED EXCAVATION ELEVATION.
 - 4) SEE CORRIDOR STANDARD SPECIFICATION 210 FOR SPECIAL EXCAVATION AND BACKFILL REQUIREMENTS WHERE SOFT CLAYS OR OTHER SOFT AND/OR WET CONDITIONS ARE ENCOUNTERED.
 - 5) FOR INFORMATION ONLY, EXISTING STORM DRAIN PLACEMENT WILL NOT HAPPEN DURING CONSTRUCTION OF WALL R-350-2. SEE DRAINAGE PLANS AND PROFILES FOR ELEVATIONS AND LOCATIONS.
 - 6) SEE ROUGH GRADING PLANS AND DETAILS FOR ADDITIONAL INFORMATION REGARDING PLACEMENT OF GEOTEXTILE OUTSIDE OF MSE WALL REINFORCEMENT ZONE.



APPROVED FOR CONSTRUCTION		DESCRIPTION	
NO.	DATE	NO.	DATE
△	4/13/98	△	10/28/98
	ORIGINAL ISSUE		MSC - 0274
UTAH DEPARTMENT OF TRANSPORTATION		WBS NO. 3112800	
MK CENTENNIAL		SVERDRUP/DE LEUW	
APPROVAL	DESIGN	CHECK	C/O
8/04/97	8/04/97	7/29/97	8/04/97
Bret A. Reynolds	Bret A. Reynolds	7/29/97	8/04/97
DATE	PROJECT DESIGN ENGINEER	DATE	PROJECT DESIGN ENGINEER
8/04/97	Randle L. Ross	8/04/97	Randle L. Ross
APPROVED	PROJECT MANAGER	DATE	PROJECT MANAGER
8/04/97		8/04/97	
I-15 CORRIDOR RECONSTRUCTION		SECTION 3.1	
WALL DETAIL R-350-2		#SP-15-7 (135)296	
SALT LAKE COUNTY		DWG. NO. 3.1R-350-2.3	
SHT. 3 OF 10		REF.	

RETAINING WALL DETAIL
WALL R-350-2
(2-STAGE MSE WALL)

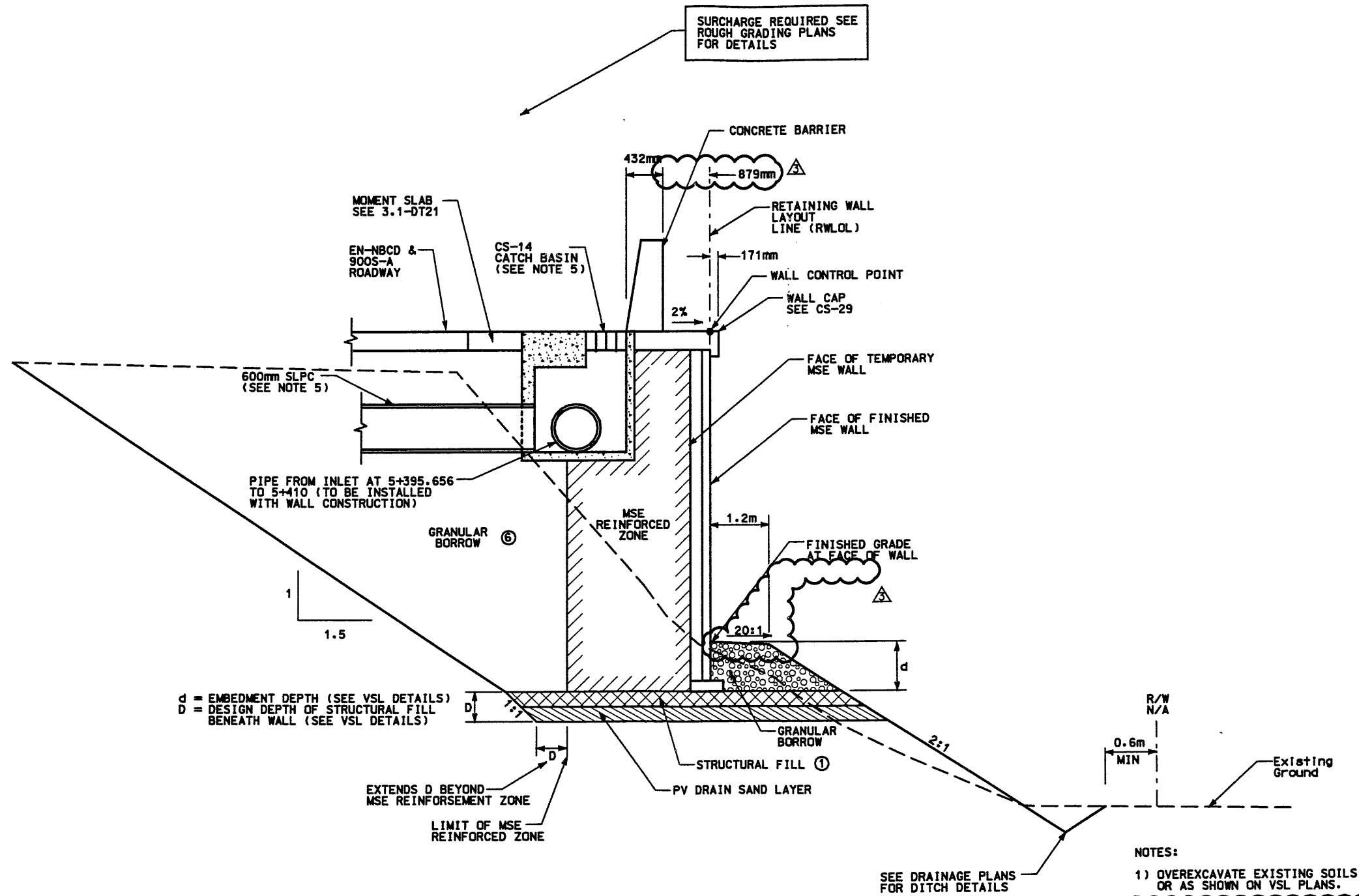

DETAIL B
STA 5+210 TO STA 5+410

NOTES:

- 1) OVEREXCAVATE EXISTING SOILS TO DEPTH (D) OF 1.0m MINIMUM OR AS SHOWN ON VSL PLANS.
- 2) SEE CORRIDOR STANDARD SPECIFICATION 221 FOR SPECIAL EXCAVATION REQUIREMENTS WHERE GROUNDWATER IS EXPECTED AT OR ABOVE THE REQUIRED EXCAVATION ELEVATION.
- 3) SEE CORRIDOR STANDARD SPECIFICATION 210 FOR SPECIAL EXCAVATION AND BACKFILL REQUIREMENTS WHERE SOFT CLAYS OR OTHER SOFT AND/OR WET CONDITIONS ARE ENCOUNTERED.
- 4) FOR INFORMATION ONLY, EXISTING STORM DRAIN PLACEMENT WILL NOT HAPPEN DURING CONSTRUCTION OF WALL R-350-2. SEE DRAINAGE PLANS AND PROFILES FOR ELEVATIONS AND LOCATIONS.
- 5) COMPACTED GRANULAR BORROW, 1.5 H TO 1 V BENCHING REQUIRED AT CONNECTION OF NEW AND EXISTING SLOPES.

After Final Approval

APPROVED FOR CONSTRUCTION	
NO.	DATE
Δ	4/13/98
Δ	10/28/98
Δ	03/08/00

UTAH DEPARTMENT OF TRANSPORTATION		MK CENTENNIAL		SVERDRUP/DE LEUW	
DESCRIPTION	WBS NO.	DESIGN DMC	CHECK CJD	DATE	PROJECT MANAGER
RELEASE FOR MSE WALL 2ND STAGE CONSTRUCTION	3112407	9/17/97	9/17/97	9/17/97	Bret A. Reynolds
ORIGINAL ISSUE					PROJECT DESIGN ENGINEER
NOC - 0274					Randie L. Robb
					DATE

1-15 CORRIDOR RECONSTRUCTION		WALL DETAIL R-350-2		SECTION 3.1	
SALT LAKE COUNTY	DWG. NO.	SHT.	OF	REF.	PROJECT NUMBER
	3.1R-350-2.4	4	10		*SP-15-7(135)296



SEALED FOR THE NO. OF RELEASE ONLY.

User: rname: webb.jp

Filename: c:\dgn\115_cadd\115_31\sheet1.dwg\115_31_ret\wall_02.dwg

RETAINING WALL DETAIL

WALL R-350-2
(2-STAGE MSE WALL)

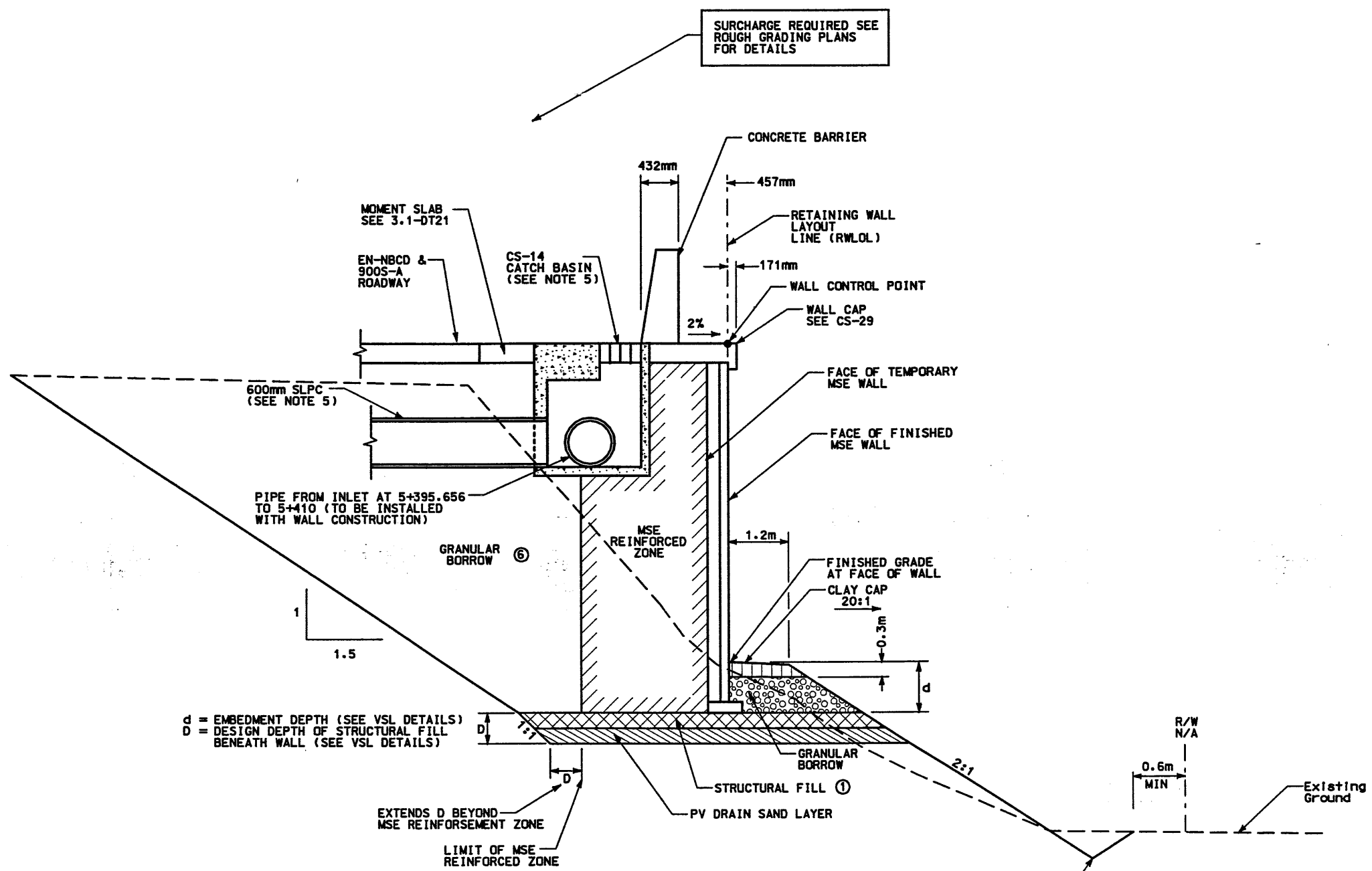

DETAIL B

STA 5+210 TO STA 5+410

WASATCH CONSTRUCTORS
NOV 02 1998
RELEASED FOR CONSTRUCTION

- NOTES:
- 1) OVEREXCAVATE EXISTING SOILS TO DEPTH (D) OF 1.0m MINIMUM OR AS SHOWN ON VSL PLANS.
 - 2) CONSTRUCT CLAY CAP WITH LOW PLASTIC SILTY CLAY (0.3m THICK).
 - 3) SEE CORRIDOR STANDARD SPECIFICATION 221 FOR SPECIAL EXCAVATION REQUIREMENTS WHERE GROUNDWATER IS EXPECTED AT OR ABOVE THE REQUIRED EXCAVATION ELEVATION.
 - 4) SEE CORRIDOR STANDARD SPECIFICATION 210 FOR SPECIAL EXCAVATION AND BACKFILL REQUIREMENTS WHERE SOFT CLAYS OR OTHER SOFT AND/OR WET CONDITIONS ARE ENCOUNTERED.
 - 5) FOR INFORMATION ONLY. EXISTING STORM DRAIN PLACEMENT WILL NOT HAPPEN DURING CONSTRUCTION OF WALL R-350-2. SEE DRAINAGE PLANS AND PROFILES FOR ELEVATIONS AND LOCATIONS.
 - 6) COMPACTED GRANULAR BORROW. 1.5 H TO 1 V BENCHING REQUIRED AT CONNECTION OF NEW AND EXISTING SLOPES.



APPROVED FOR CONSTRUCTION		
NO.	DATE	DESCRIPTION
A	4/13/98	ORIGINAL ISSUE
A	10/28/98	MOC - 0274
A	/ /	/ /
A	/ /	/ /

UTAH DEPARTMENT OF TRANSPORTATION MK CENTENNIAL SVERDRUP/DE LEUW		
DESIGN DMC: 7/29/97	CHECK C.U.O. 9/17/97	WBS NO. 3112800
DESIGN: Bret A. Reynolds	DRWN: N/A	QUANT: / /
DATE: 9/17/97	APPROVAL DATE: 9/17/97	
PROJECT DESIGN ENGINEER: Randle L. Ross	PROJECT MANAGER: / /	
APPROVED: 9/17/97	DATE: / /	

I-15 CORRIDOR RECONSTRUCTION	WALL DETAIL R-350-2	SECTION 3.1
		PROJECT NUMBER #SP-15-7(135)296
SALT LAKE COUNTY		
DWG. NO. 3.1R-350-2.4		
SHT. 4 OF 10		
REF.		

FINAL 04-15-98 H:\RE_EARTH\PROJECT\239-0007\1998\1-3-102\SUBMITL-2\RE-1

APPROVED FOR CONSTRUCTION		
NO.	DATE	DESCRIPTION
▲	04-15-98	RELEASE FOR CONSTRUCTION 1st STAGE ONLY

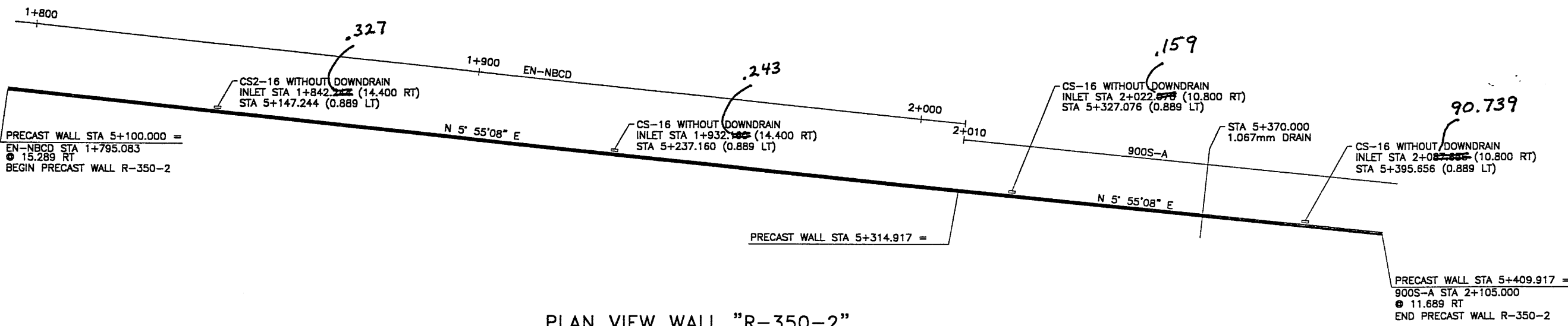

PLAN VIEW WALL "R-350-2"
 SCALE: 1=250 (FULL SIZE)
 SCALE: 1=500 (HALF SIZE)

DESIGN PARAMETERS
ANGLE OF INTERNAL FRICTION (SELECT) = 34°
ANGLE OF INTERNAL FRICTION (BASE) = 34°
ANGLE OF INTERNAL FRICTION (RANDOM) = 34°
UNIT WEIGHT BACKFILL = 135 PCF. (21.2 KN/M ³)
TRAFFIC SURCHARGE = 250 PSF (12 KPa)
SEISMIC ACCELERATION COFF. = 0.27g (TYP)
DESIGN CRITERIA
SAFETY FACTOR (OVERTURNING) = 2.0
SAFETY FACTOR (SLIDING) = 1.5
SAFETY FACTOR (PULLOUT) = 1.5
DESIGN LIFE = 75 YEARS

RETAINED EARTH INDEX	
RE-1	PLAN PRECAST FACE WALL R-350-02, NOTES & DESIGN CRITERIA
RE-2	TYPICAL CROSS SECTION
RE-3	TYPICAL CROSS SECTION
RE-4	ELEVATION PRECAST WALL "R-350-2"
RE-5	ELEVATION PRECAST WALL "R-350-2"
RE-6	ELEVATION PRECAST WALL "R-350-2"

WASATCH CONSTRUCTORS

APR 13 1998

RELEASED FOR CONSTRUCTION

LICENSED PROFESSIONAL ENGINEER

No. 344796

JOHN A. NICHOLSON, JR.

4/13/98

STATE OF UTAH

METRIC

CERTIFIED FOR INTERNAL STABILITY OF RETAINED EARTH™ STRUCTURES ONLY. EXTERNAL STABILITY, INCLUDING BUT NOT LIMITED TO FOUNDATION AND SLOPE STABILITY, IS THE RESPONSIBILITY OF THE OWNER. DESIGN IS BASED ON THE ASSUMPTION THAT THE MATERIAL WITHIN THE RETAINED EARTH™ MASS, METHODS OF CONSTRUCTION, AND QUALITY OF PREFABRICATED MATERIALS CONFORM TO THE MANUFACTURER'S SPECIFICATION.

NO.	DATE	DESCRIPTION	BY	CHK

DES.	02-23-98	JL	RETAINED EARTH™
DRN.	02-23-98	LOP	
CHK.	02-23-98	JL	

VSL CORPORATION
 2840 Plaza Place, Suite 200
 Raleigh, NC 27612
 Telephone: (919) 781-8772
 Fax: (919) 781-6959

VSL

ATLANTA, GA / DALLAS, TX / RALEIGH, NC (CORPORATE OFFICE)
 MIAMI, FL / SAN JOSE, CA / SPRINGFIELD, VA

RETAINED EARTH™ WALLS
 PLAN VIEW PRECAST WALL "R-350-2"
 UTAH I-15 RECONSTRUCTION
 SALT LAKE COUNTY, UTAH
 UTAH DEPARTMENT OF TRANSP.

DWG. NO. 3.1R-350-2.5
 JOB NO. 239-0007
 SHEET NO. RE-1

SHT 5 OF 10

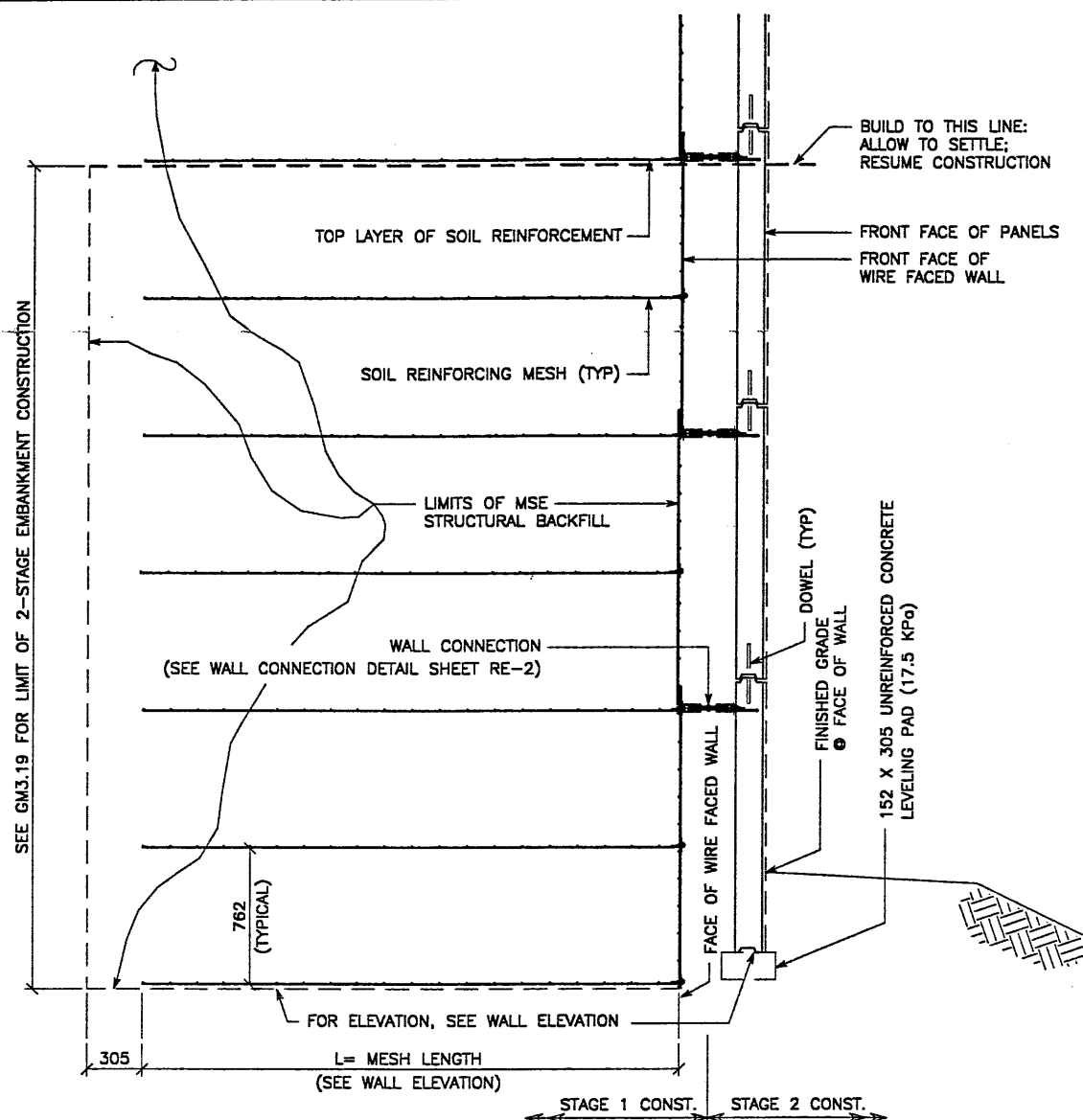

TYPICAL CROSS SECTION AT VERTICAL PHASE CONST.
 SCALE: 1:20 (FULL SIZE)
 SCALE: 1:40 (HALF SIZE)

SEE VSL STD DWG FOR PLACEMENT OF INTERMEDIATE SOIL REINFORCEMENT

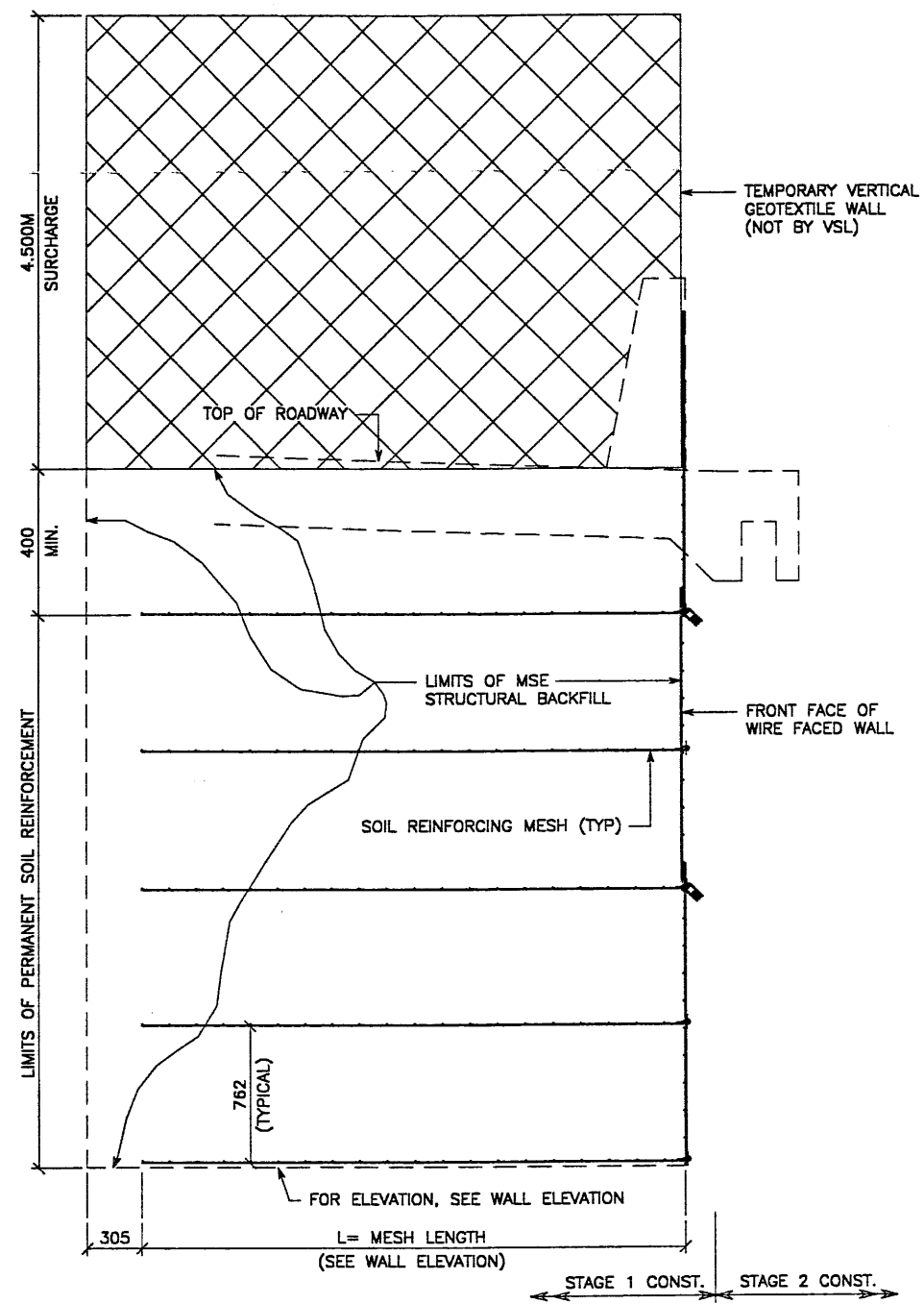

TYPICAL CROSS SECTION AT FINAL PHASE OF WIRE FACE WALL
 SCALE: 1:20 (FULL SIZE)
 SCALE: 1:40 (HALF SIZE)

APPROVED FOR CONSTRUCTION		
NO.	DATE	DESCRIPTION
▲	04-15-98	RELEASE FOR CONSTRUCTION 1st STAGE ONLY

DES.	DRN.	CHK.	NO.	DATE	BY
JL	LOP	JL			

VSL CORPORATION
 2840 Rock Place, Suite 200
 Raleigh, NC 27612
 Telephone: (919) 781-5272
 Fax: (919) 781-4889



ATLANTA, GA / DALLAS, TX / RALEIGH, NC (CORPORATE OFFICE)
 MIAMI, FL / SAN JOSE, CA / SPRINGFIELD, VA

VSL Corporation hereby certifies that the design and construction of the structure shown on this sheet, in accordance with the specifications and drawings, is the responsibility of the engineer. The use of the VSL logo on this sheet is the property of VSL Corporation and its use without the written consent of VSL Corporation is prohibited. Any other use of this sheet is strictly prohibited. VSL CORPORATION ACCEPTS NO LIABILITY THEREFOR.

WASATCH CONSTRUCTORS
 APR 13 1998
 RELEASED FOR CONSTRUCTION

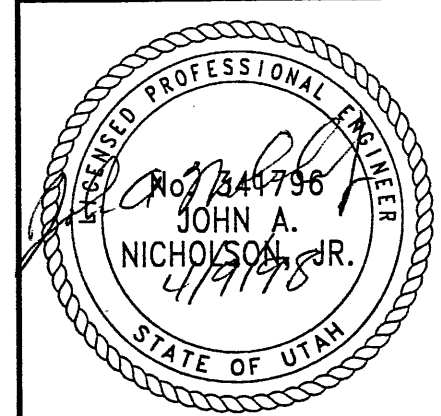

RETAINED EARTH™ WALLS
 WIRE FACED WALL "R-350-2"
 TYPICAL SECTIONS • WIRE FACED WALL
 UTAH I-15 INTERCHANGE
 SALT LAKE COUNTY, UTAH
 UTAH DEPARTMENT OF TRANSP.

DWG. NO.	3.1R-350-2.6
JOB NO.	239-0007
SHT. NO.	RE-2

CERTIFIED FOR INTERNAL STABILITY OF RETAINED EARTH™ STRUCTURES ONLY. EXTERNAL STABILITY, INCLUDING BUT NOT LIMITED TO FOUNDATION AND SLOPE STABILITY, IS THE RESPONSIBILITY OF THE OWNER. DESIGN IS BASED ON THE ASSUMPTION THAT THE MATERIAL WITHIN THE RETAINED EARTH™ MASS, METHODS OF CONSTRUCTION, AND QUALITY OF PREFABRICATED MATERIALS CONFORM TO THE MANUFACTURER'S SPECIFICATION.

METRIC

XRE-2 (X-UTAH.DWG)
 H:\RE_EARTH\PROJECT\239-0007\1998\135. J-102\SUBMITL-2\RE-3
 4-15-98
 FINAL

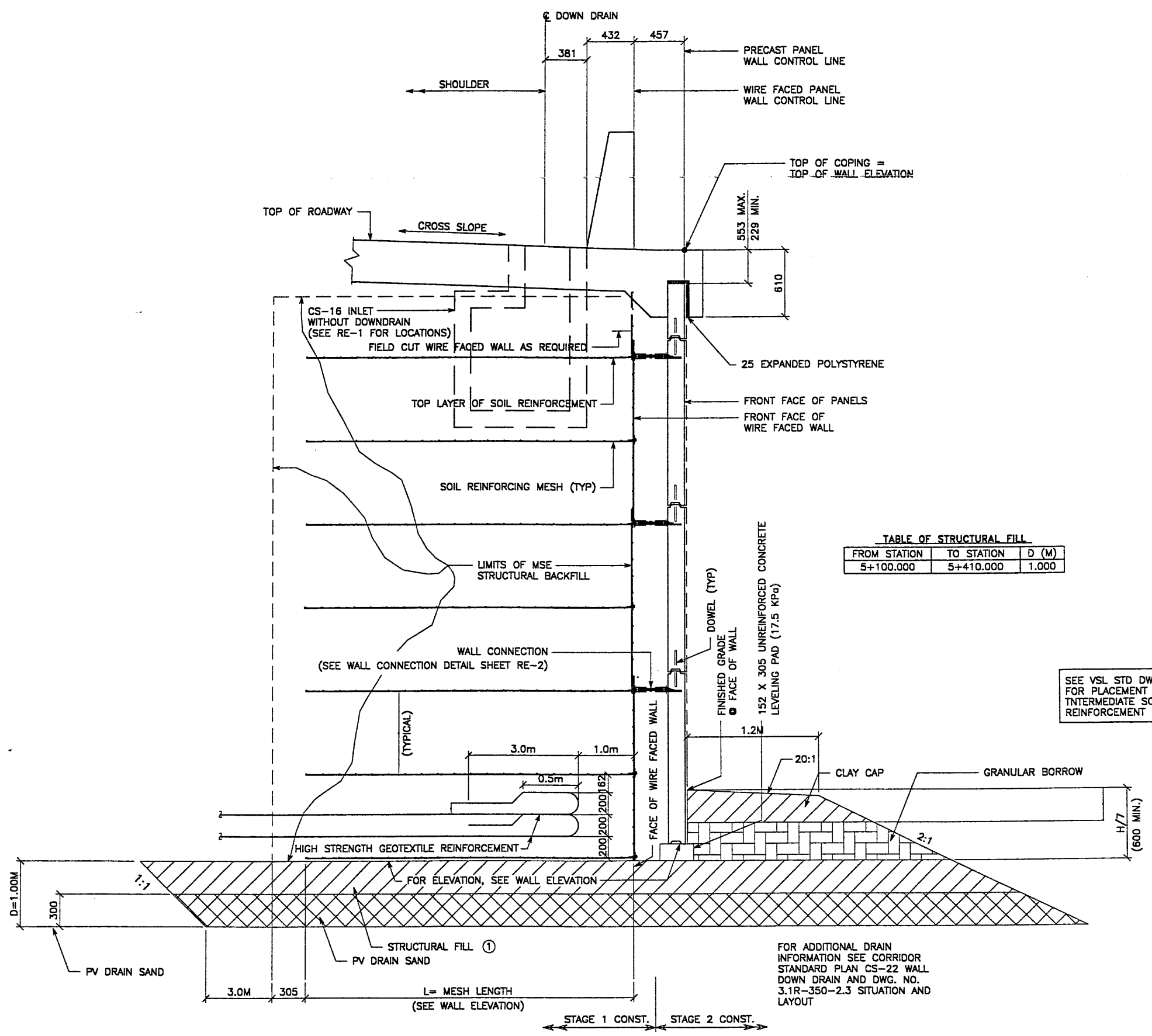

TABLE OF STRUCTURAL FILL

FROM STATION	TO STATION	D (M)
5+100.000	5+410.000	1.000

SEE VSL STD DWG FOR PLACEMENT OF INTERMEDIATE SOIL REINFORCEMENT

FOR ADDITIONAL DRAIN INFORMATION SEE CORRIDOR STANDARD PLAN CS-22 WALL DOWN DRAIN AND DWG. NO. 3.1R-350-2.3 SITUATION AND LAYOUT

TYPICAL CROSS SECTION STA. 5+100 - 5+200
CROSS SECTION STA. 5+200 - 5+300 (NO GEOTEXTILE REINFORCEMENT)
 SCALE: 1:20 (FULL SIZE)
 SCALE: 1:40 (HALF SIZE)

APPROVED FOR CONSTRUCTION

NO.	DATE	DESCRIPTION
1	04-15-98	RELEASE FOR CONSTRUCTION 1ST STAGE ONLY

DES.	DRN.	CHK.	NO.	DATE	BY	CHK
JL	LOP	JL				

VSL CORPORATION
 2840 Plaza Place, Suite 200
 Raleigh, NC 27612
 Telephone: (919) 781-4272
 Fax: (919) 781-4889

VSL
 ATLANTA, GA / DALLAS, TX / BALDWIN, NC (CORPORATE OFFICE)
 MIAMI, FL / SAN JOSE, CA / SPRINGFIELD, IL

WASATCH CONSTRUCTORS
APR 13 1998
RELEASED FOR CONSTRUCTION

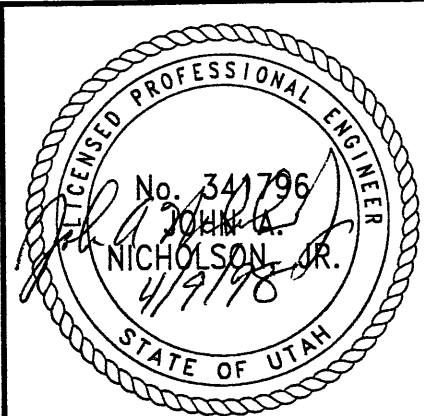

RETAINED EARTH™ WALLS
WIRE FACED WALL™ R-350-2
TYPICAL CROSS SECTION
UTAH I-15 INTERCHANGE
SALT LAKE COUNTY, UTAH
UTAH DEPARTMENT OF TRANSP.

DWG. NO.
3.1R-350-2.7
 JOB NO.
239-0007
 SHEET NO.
RE-3

CERTIFIED FOR INTERNAL STABILITY OF RETAINED EARTH™ STRUCTURES ONLY. EXTERNAL STABILITY, INCLUDING BUT NOT LIMITED TO FOUNDATION AND SLOPE STABILITY, IS THE RESPONSIBILITY OF THE OWNER. DESIGN IS BASED ON THE ASSUMPTION THAT THE MATERIAL WITHIN THE RETAINED EARTH™ MASS, METHODS OF CONSTRUCTION, AND QUALITY OF PREFABRICATED MATERIALS CONFORM TO THE MANUFACTURER'S SPECIFICATION.

BEGIN WIRE FACED WALL R-350-02
WIRE FACED WALL STA 5+100.000 =
EN-NBCD STA 1+795.083
@ 14.832 RT

BEGIN WALL

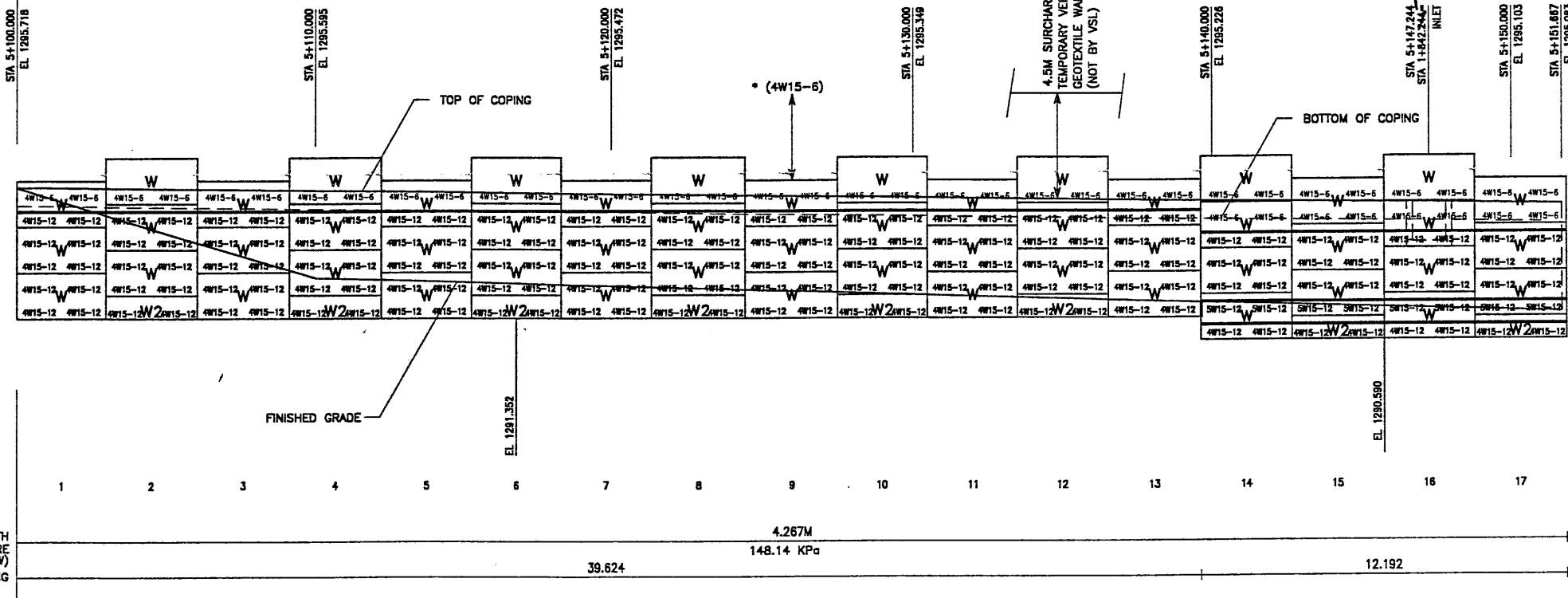

MATCH LINE - 1

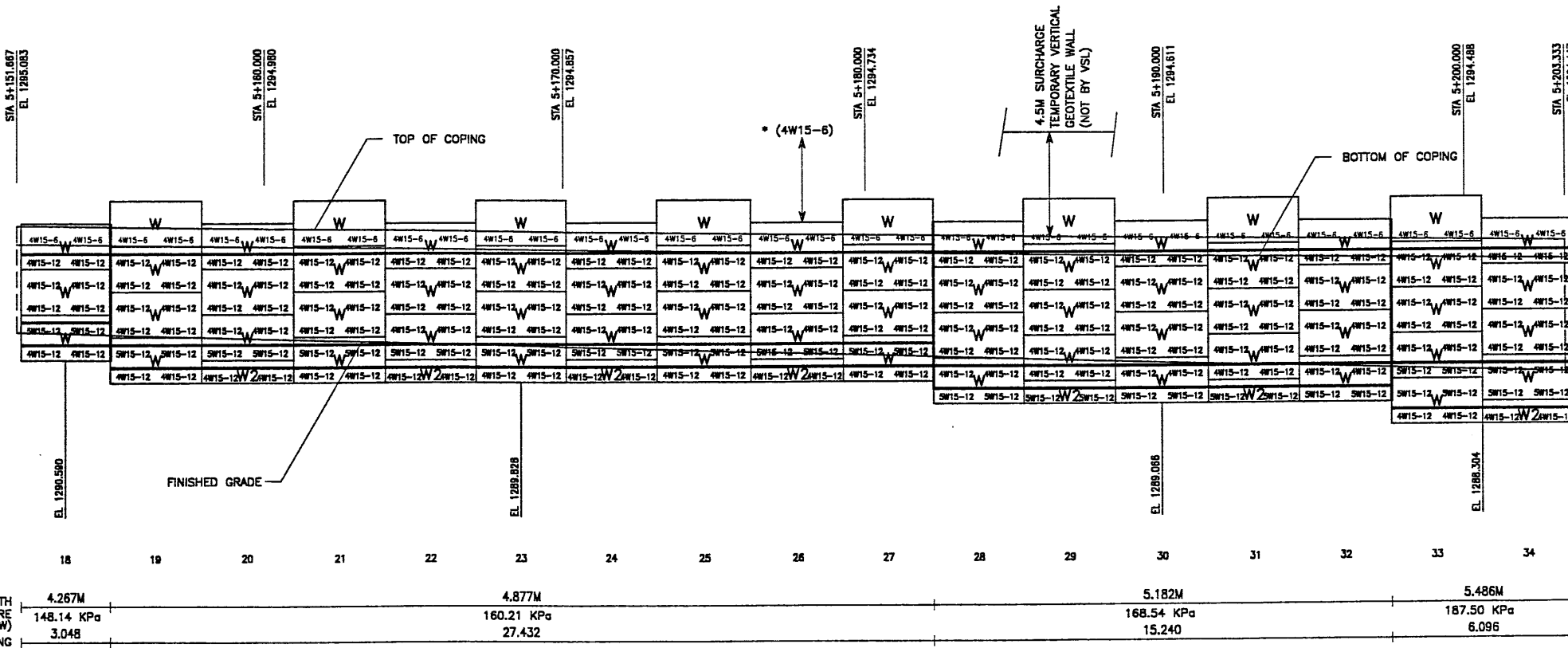

MATCH LINE - 2

RETAINING WALL "R-350-02" - 1ST STAGE: WIRE FACED WALL

(FRONT FACE SHOWN)
(TOTAL SURFACE AREA OF FACING = 1841.90 SM)

SCALE 1:100 (FULL SIZE)
SCALE 1:200 (HALF SIZE)

METRIC

* INDICATES SOIL REINFORCING TYPE
MESH TO BE USED ON ADDITIONAL
WIRE WALL FACING ADDED AFTER SETTLEMENT.

NOTE: THE INDICATED MAX. APPLIED BEARING PRESSURE
AT FINAL STAGE FOR STATIC LOAD COMBINATION

CERTIFIED FOR INTERNAL STABILITY OF RETAINED EARTH™ STRUCTURES ONLY.
EXTERNAL STABILITY, INCLUDING BUT NOT LIMITED TO FOUNDATION AND SLOPE
STABILITY, IS THE RESPONSIBILITY OF THE OWNER. DESIGN IS BASED ON THE
ASSUMPTION THAT THE MATERIAL WITHIN THE RETAINED EARTH™ MASS, METHODS
OF CONSTRUCTION, AND QUALITY OF PREFABRICATED MATERIALS CONFORM TO
THE MANUFACTURER'S SPECIFICATION.

APPROVED FOR CONSTRUCTION		
NO.	DATE	DESCRIPTION
1	04-15-98	RELEASE FOR CONSTRUCTION 1st STAGE ONLY

DES.	DRN.	CHK.	RETAINED EARTH™	NO.	DATE	REVISION	CHK
JL	LOP	JL					

VSL CORPORATION
2840 Plaza Place, Suite 200
Raleigh, NC 27612
Telephone: (919) 781-8272
Fax: (919) 781-0859

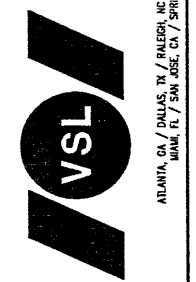

VSL Corporation (VSL) is
right in its design, spec-
ification, and construction
of retaining walls. The use of
retained earth™ structures
is in part, or any other
manner, without the written
consent of VSL. VSL
warrants that the design and
construction of retaining walls
conform to the VSL
specification. VSL
WARRANTS ANY LIABILITY
CLAIMS THEREFOR.

WASATCH CONSTRUCTORS
APR 13 1998
RELEASED FOR CONSTRUCTION

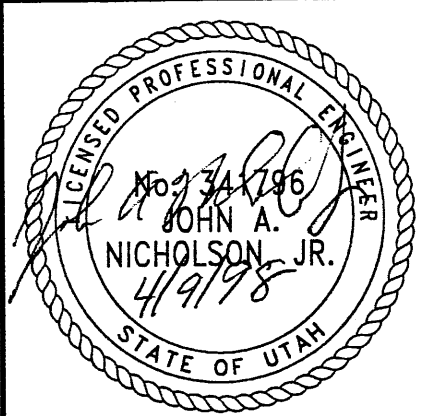

RETAINED EARTH™ WALLS
WALL "R-350-2" - 1ST STAGE: WIRE FACED WALL
UTAH I-15 INTERCHANGE
SALT LAKE COUNTY, UTAH
UTAH DEPARTMENT OF TRANSP.

DWG. NO.	3.1R-350-2.8
JOB NO.	239-0007
SHT. NO.	RE-4

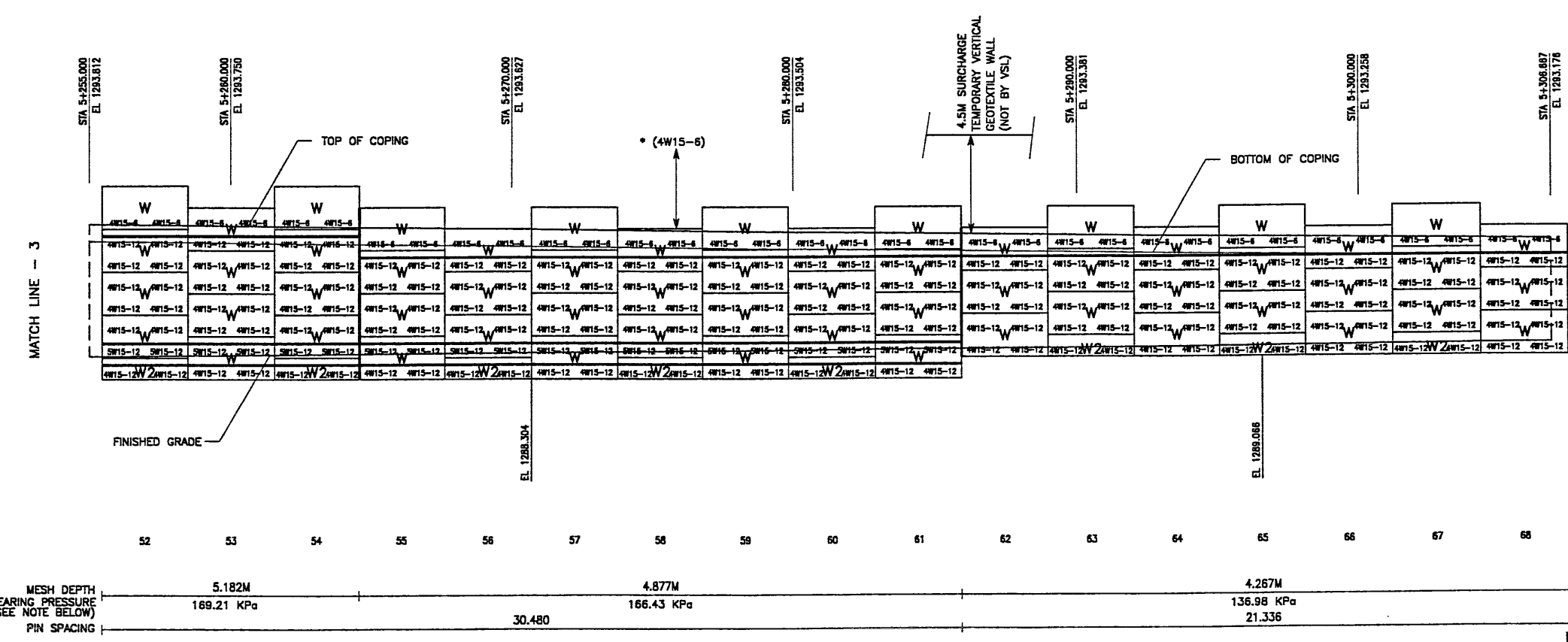
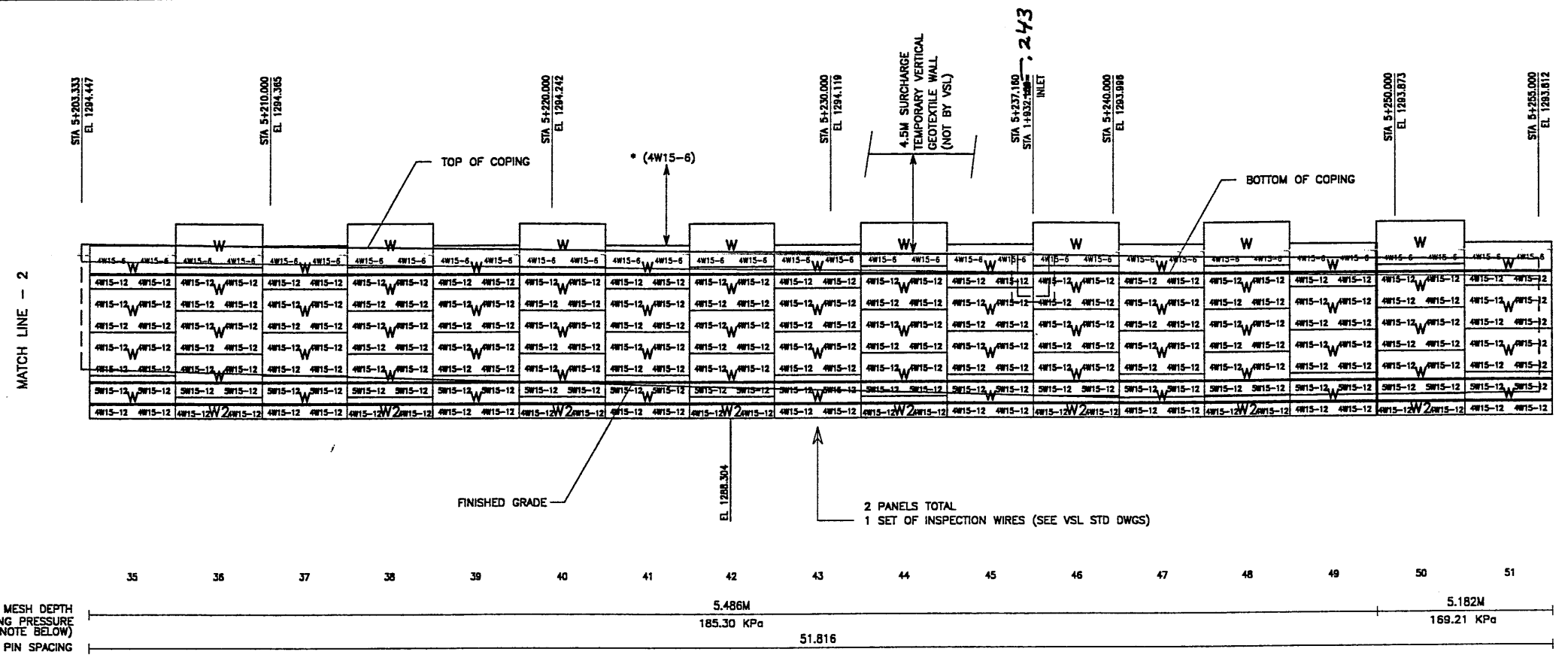

RETAINING WALL "R-350-02" - 1ST STAGE: WIRE FACED WALL

(FRONT FACE SHOWN)
(TOTAL SURFACE AREA OF FACING = 1640.12 SM)

SCALE 1:100 (FULL SIZE)
SCALE 1:200 (HALF SIZE)

METRIC

* INDICATES SOIL REINFORCING TYPE
MESH TO BE USED ON ADDITIONAL
WIRE WALL FACING ADDED AFTER SETTLEMENT.
NOTE: THE INDICATED MAX. APPLIED BEARING PRESSURE
AT FINAL STAGE FOR STATIC LOAD COMBINATION

CERTIFIED FOR INTERNAL STABILITY OF RETAINED EARTH™ STRUCTURES ONLY.
EXTERNAL STABILITY, INCLUDING BUT NOT LIMITED TO FOUNDATION AND SLOPE
STABILITY, IS THE RESPONSIBILITY OF THE OWNER. DESIGN IS BASED ON THE
ASSUMPTION THAT THE MATERIAL WITHIN THE RETAINED EARTH™ MASS, METHODS
OF CONSTRUCTION, AND QUALITY OF PREFABRICATED MATERIALS CONFORM TO
THE MANUFACTURER'S SPECIFICATION.

APPROVED FOR CONSTRUCTION		
NO.	DATE	DESCRIPTION
△ 04-15-98		RELEASE FOR CONSTRUCTION 1st STAGE ONLY

DES.	DRN.	CHK.	RETAINED EARTH™	NO.	DATE	REVISION	BY	CHK.
02-23-98	JL	LOP						
02-23-98	JL	LOP						
02-23-98	JL	LOP						

VSL CORPORATION
2840 Plaza Place, Suite 200
Raleigh, NC 27612
Telephone: (919) 781-6772
Fac: (919) 781-6999

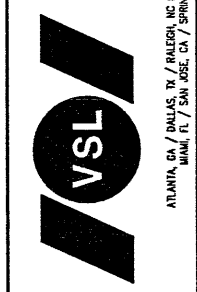

VSL Corporation (PCL)
is a VSL proprietary
design and construction
methodology for earth
retention and stabilization
structures. VSL is not
responsible for any
design or construction
errors or omissions
attributed to the site for
retained earth structures
designed by VSL.
VSL is not responsible for
any design or construction
errors or omissions
attributed to the site for
retained earth structures
designed by VSL.

WASATCH CONSTRUCTORS
APR 13 1998
RELEASED FOR CONSTRUCTION

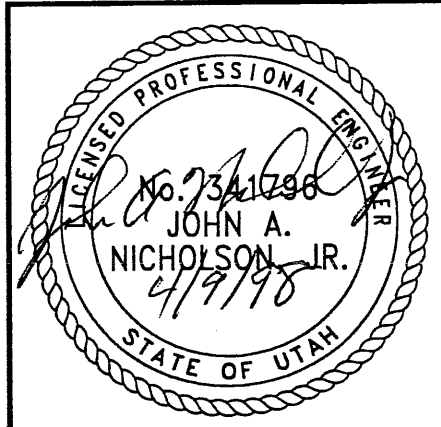

RETAINED EARTH™ WALLS
WALL "R-350-2" - 1ST STAGE: WIRE FACED WALL
UTAH I-15 INTERCHANGE
SALT LAKE COUNTY, UTAH
UTAH DEPARTMENT OF TRANSP.

DWG. NO.	2.3R-350-2.9
JOB NO.	239-0007
SHT. NO.	RE-5

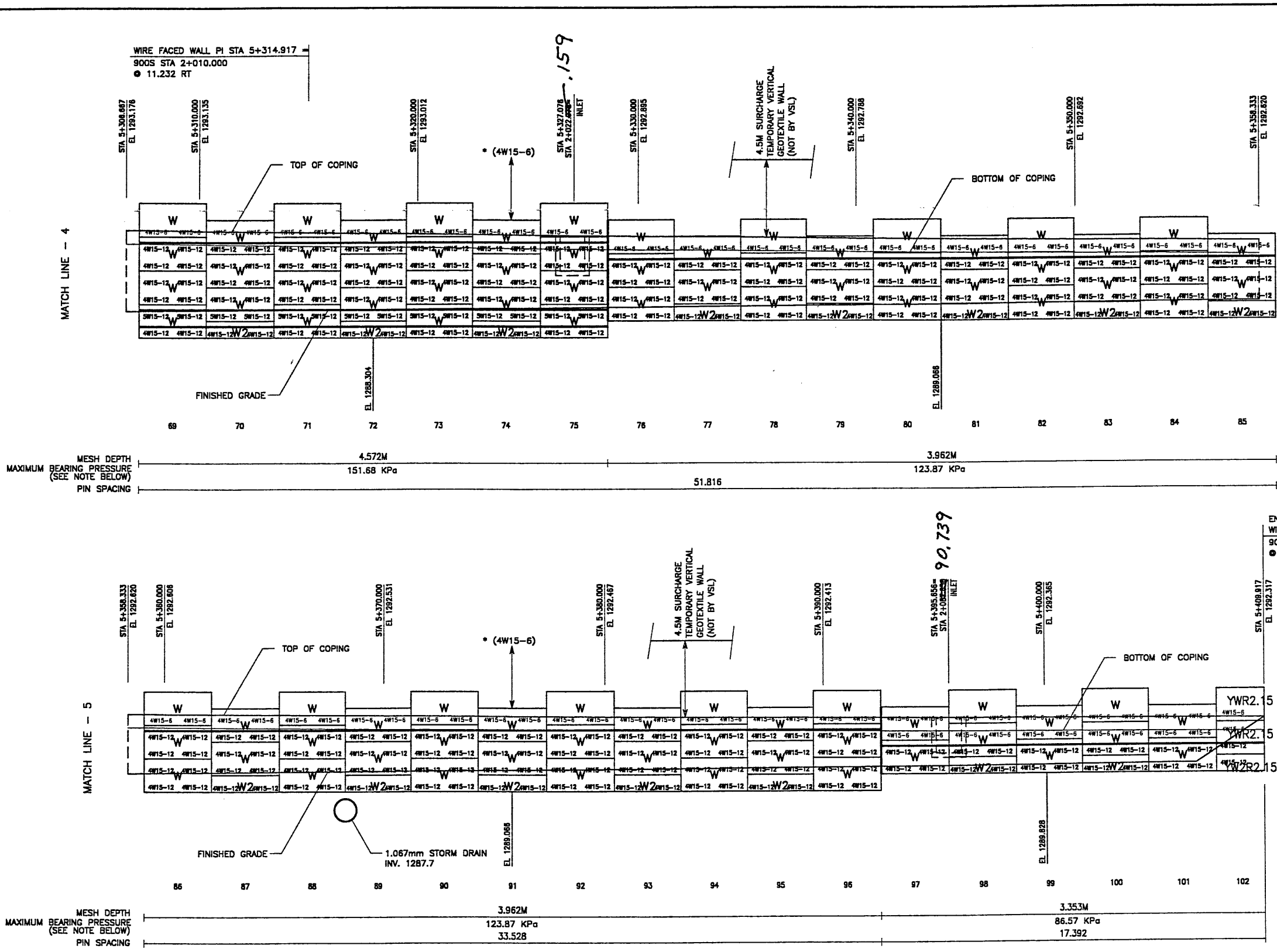

RETAINING WALL "R-350-02" - 1ST STAGE: WIRE FACED WALL
 (FRONT FACE SHOWN) SCALE 1:100 (FULL SIZE)
 (TOTAL SURFACE AREA OF FACING = 1640.12 SM) SCALE 1:200 (HALF SIZE)

METRIC

CERTIFIED FOR INTERNAL STABILITY OF RETAINED EARTH™ STRUCTURES ONLY. EXTERNAL STABILITY, INCLUDING BUT NOT LIMITED TO FOUNDATION AND SLOPE STABILITY, IS THE RESPONSIBILITY OF THE OWNER. DESIGN IS BASED ON THE ASSUMPTION THAT THE MATERIAL WITHIN THE RETAINED EARTH™ MASS, METHODS OF CONSTRUCTION, AND QUALITY OF PREFABRICATED MATERIALS CONFORM TO THE MANUFACTURER'S SPECIFICATION.

* INDICATES SOIL REINFORCING TYPE MESH TO BE USED ON ADDITIONAL WIRE WALL FACING ADDED AFTER SETTLEMENT.
 NOTE: THE INDICATED MAX. APPLIED BEARING PRESSURE AT FINAL STAGE FOR STATIC LOAD COMBINATION

APPROVED FOR CONSTRUCTION		
NO.	DATE	DESCRIPTION
△	04-15-98	RELEASE FOR CONSTRUCTION 1st STAGE ONLY

DES.	DRN.	CHK.	NO.	DATE	REVISION	CHK
02-23-98	02-23-98	02-23-98	JL	JL	LOP	JL

VSL CORPORATION
 2840 Plaza Place, Suite 200
 Raleigh, NC 27612
 Telephone: (919) 781-8272
 Fax: (919) 781-4989

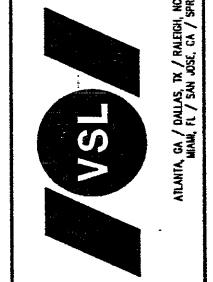

ATLANTA, GA / DALLAS, TX / HALSIGH, INC. (CORPORATE OFFICE)
 MIAMI, FL / SAN JOSE, CA / SPRINGFIELD, VA

WASATCH CONSTRUCTORS
 APR 13 1998
 RELEASED FOR CONSTRUCTION

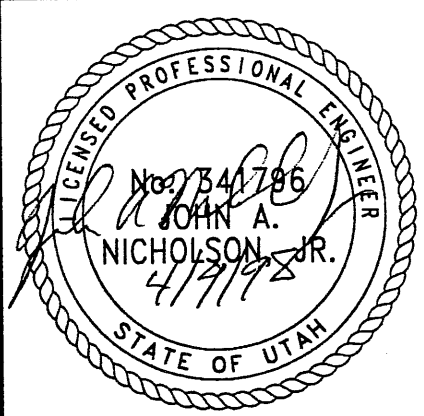

RETAINED EARTH™ WALLS
 WALL "R-350-2" - 1ST STAGE: WIRE FACED WALL
 UTAH I-15 INTERCHANGE
 SALT LAKE COUNTY, UTAH
 UTAH DEPARTMENT OF TRANSP.

DWG. NO.	2.3R-350-2.10
JOB NO.	239-0007
SHT. NO.	RE-6

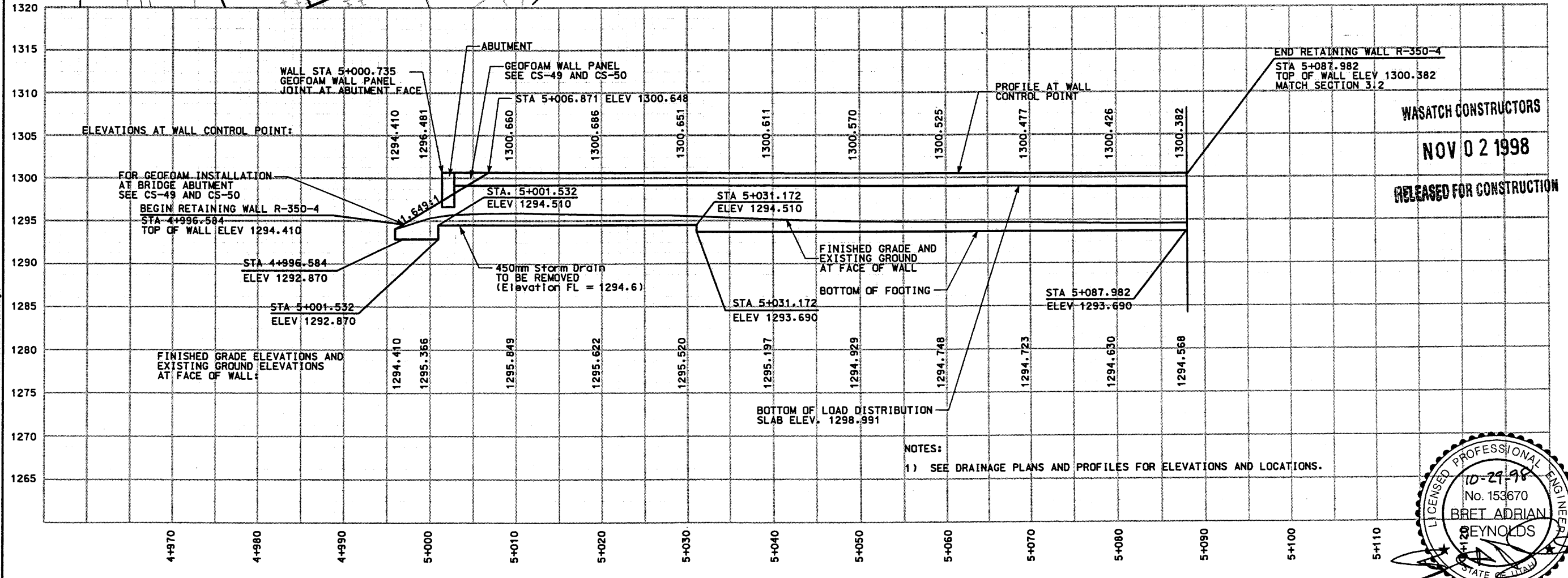
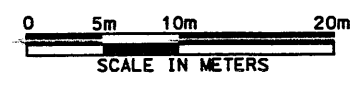
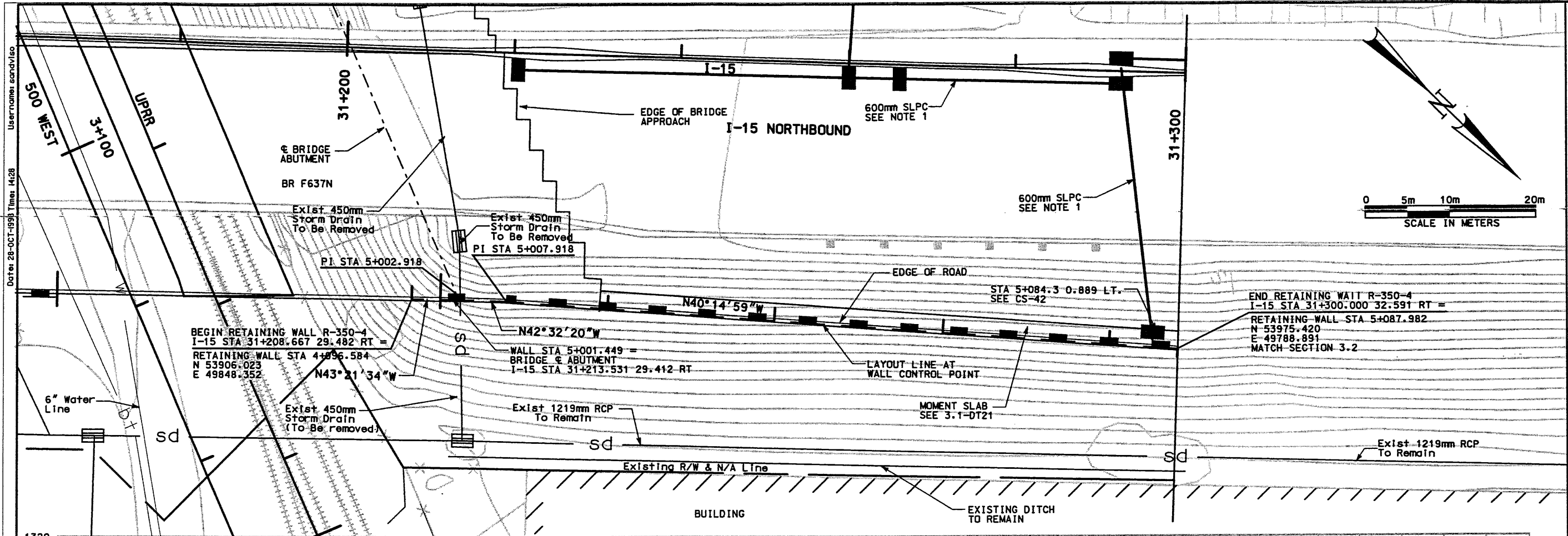

ELEVATION VIEW - FACE OF WALL

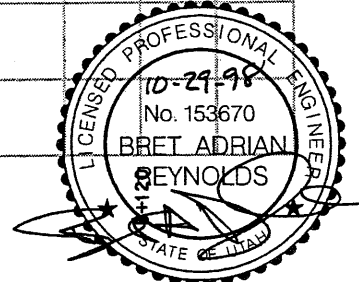

APPROVED FOR CONSTRUCTION		DESCRIPTION	
NO.	DATE	REVISION	ELEVATION AT ABUTMENT
1	4/14/98		
2	10/28/98		NOC - 0274
3			
4			
UTAH DEPARTMENT OF TRANSPORTATION		MK CENTENNIAL	
SVERDRUP/DE LEUW		DESIGN JOB	10/29/97
		CHECK JOB	11/12/97
		DESIGN JOB	11/13/97
		CHECK JOB	11/13/97
		DESIGN JOB	3/11/98
		CHECK JOB	3/19/98
I-15 CORRIDOR RECONSTRUCTION		SITUATION & LAYOUT R-350-4	
SECTION 3.1		PROJECT NUMBER #SP-15-(135)296	
SALT LAKE COUNTY		DWG. NO. 3.1R-350-4.1	
SHT. 1 OF 3		REF.	

WASATCH CONSTRUCTORS
 NOV 02 1998
 RELEASED FOR CONSTRUCTION

NOTES:
 1) SEE DRAINAGE PLANS AND PROFILES FOR ELEVATIONS AND LOCATIONS.

Usernames: sarradviso
 Date: 28-OCT-1998 Time: 14:28
 File: P:\115.cadd\115.cadd\115_97\sheet_31_rctwall_04_01.dgn

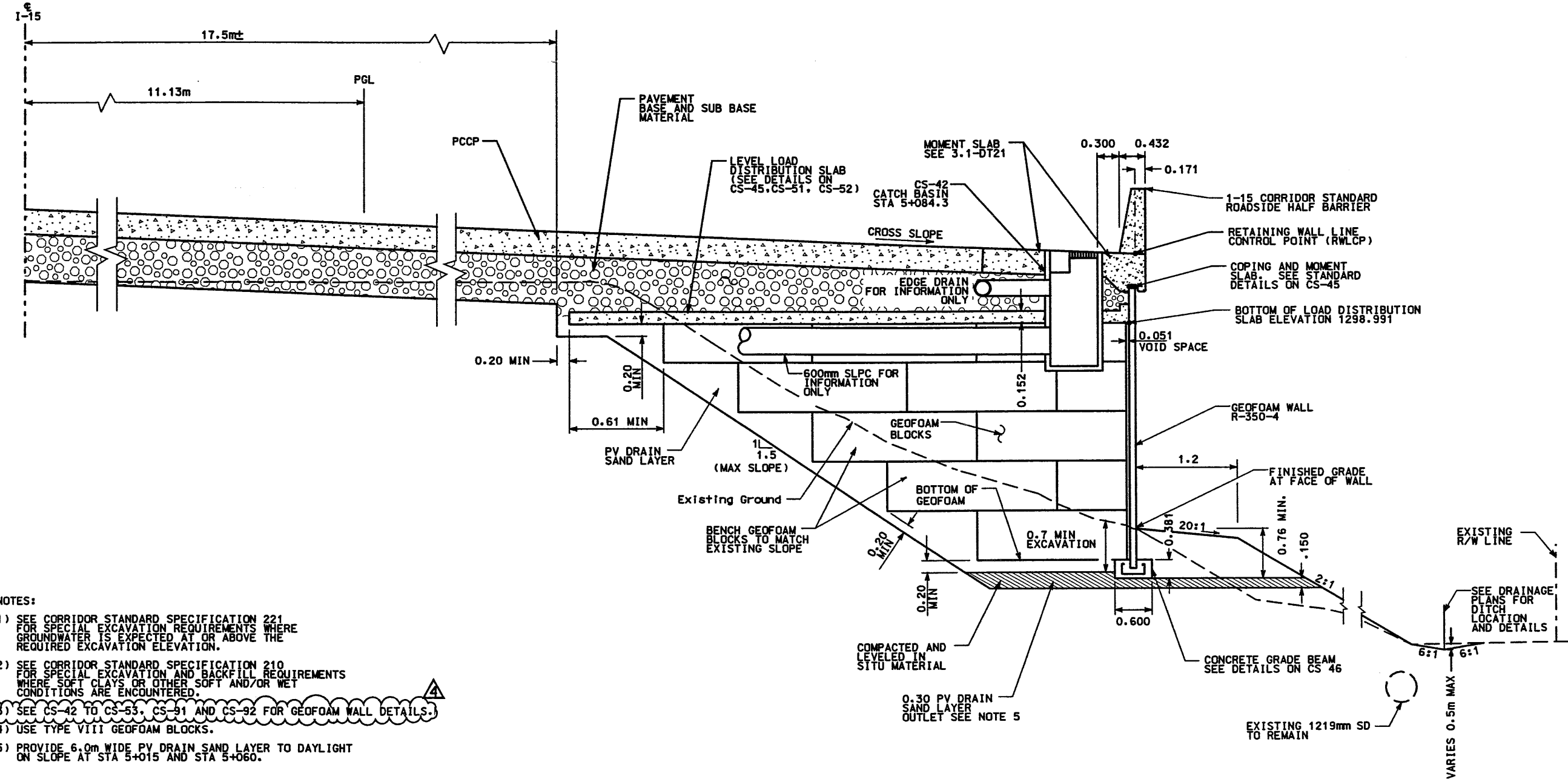

- NOTES:**
- SEE CORRIDOR STANDARD SPECIFICATION 221 FOR SPECIAL EXCAVATION REQUIREMENTS WHERE GROUNDWATER IS EXPECTED AT OR ABOVE THE REQUIRED EXCAVATION ELEVATION.
 - SEE CORRIDOR STANDARD SPECIFICATION 210 FOR SPECIAL EXCAVATION AND BACKFILL REQUIREMENTS WHERE SOFT CLAYS OR OTHER SOFT AND/OR WET CONDITIONS ARE ENCOUNTERED.
 - SEE CS-42 TO CS-53, CS-91 AND CS-92 FOR GEOFOAM WALL DETAILS.
 - USE TYPE VIII GEOFOAM BLOCKS.
 - PROVIDE 6.0m WIDE PV DRAIN SAND LAYER TO DAYLIGHT ON SLOPE AT STA 5+015 AND STA 5+060.

RETAINING WALL DETAILS
WALL R-350-4
(GEOFOAM WALL)
N.T.S.

WASATCH CONSTRUCTORS
 APR 20 1998
 RELEASED FOR CONSTRUCTION

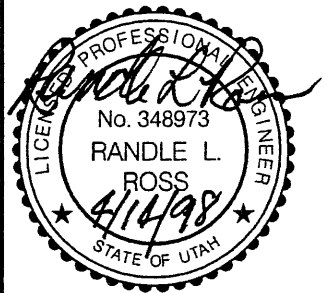

APPROVED FOR CONSTRUCTION		DESCRIPTION	
NO.	DATE	ORIGINAL ISSUE	REVISE
1	11/19/97	11/19/97	11/19/97
2	1/21/98	1/21/98	1/21/98
3	3/25/98	3/25/98	3/25/98
4	4/14/98	4/14/98	4/14/98
UTAH DEPARTMENT OF TRANSPORTATION		WBS NO. 3112300	
MK CENTENNIAL SVERDRUP/DE LEUW		CHECK C/J/D 11/14/97	
DESIGN	11/13/97	DESIGN	11/13/97
DRAWN	11/13/97	DRAWN	11/13/97
QUANT.	11/13/97	QUANT.	11/13/97
DATE	11/13/97	DATE	11/13/97
PROJECT MANAGER	Randle L. Ross	PROJECT MANAGER	Randle L. Ross
APPROVAL	11/18/97	APPROVAL	11/18/97
DATE	11/18/97	DATE	11/18/97
1-15 CORRIDOR RECONSTRUCTION		WALL DETAIL R-350-4	
SECTION 3.1		PROJECT NUMBER #SP-15-7(135)296	
SALT LAKE COUNTY		DWG. NO. 3.1R-350-4.2	
SHT.	2	OF	3
REF.			

DATE OF ISSUE: 11/15/97

PROJECT NO. 15-7(135)1296

THE INFORMATION ON THIS SHEET HAS BEEN DELETED

WASATCH CONSTRUCTORS
MAR 13 1998
RELEASED FOR CONSTRUCTION



PRELIMINARY
NOT FOR CONSTRUCTION

1-15 CORRIDOR RECONSTRUCTION WALL DETAIL R-350-4		UTAH DEPARTMENT OF TRANSPORTATION M.K. CENTENNIAL SEVERDUP/DE LEBL		APPROVED FOR CONSTRUCTION	
SECTION 3.1		DESIGNED BY: Brett A. Reynolds CHECKED BY: [Signature]		NO. DATE	DESCRIPTION
PROJECT NUMBER: MSP-15-7(135)1296		DATE: 11/15/97		1 11/15/97	WALL DETAIL R-350-4
SALT LAKE COUNTY		DATE: 11/15/97		2 11/15/97	WALL DETAIL R-350-4
SHEET NO. 3		DATE: 11/15/97		3 11/15/97	WALL DETAIL R-350-4
TOTAL SHEETS 3		DATE: 11/15/97		4 11/15/97	WALL DETAIL R-350-4

Username: almonrjh

Date: 12-JAN-1999 Time: 09:35

Filename: c:\p1\115_cadd\13_97\Fig_99\sheet_3_files\wall3_rctwall-1.dwg

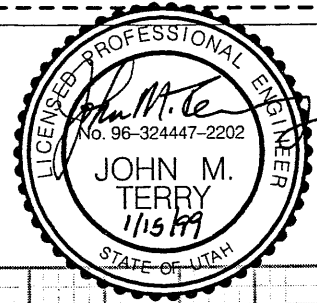
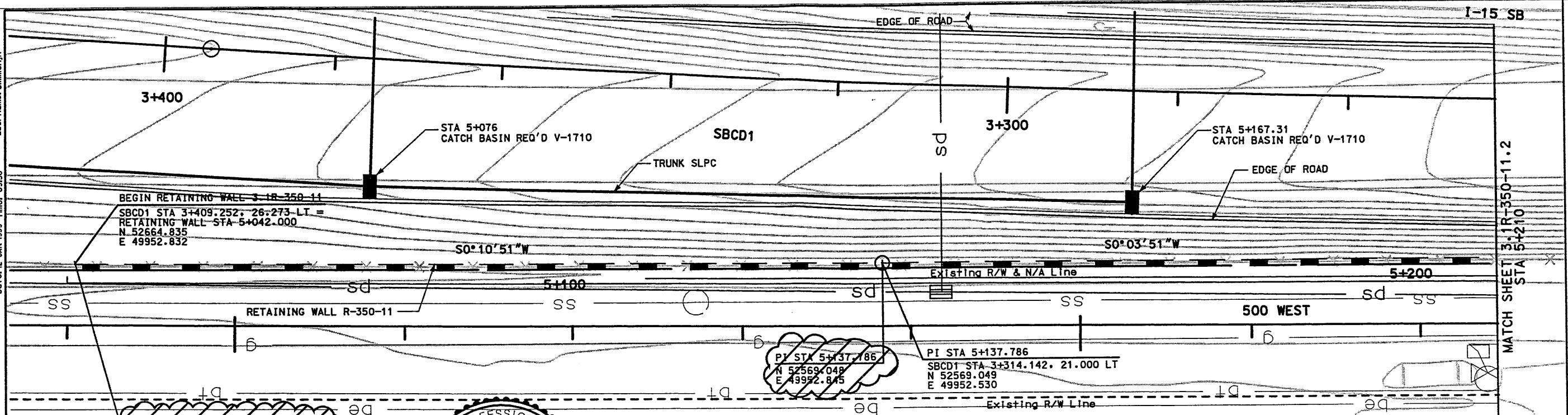

SEALED FOR RELEASE NO. 5 ONLY.
 (REALIGNMENT OF RETAINING WALL
 CONTROL POINT DUE TO FIRST STAGE
 SETTLEMENT AND SECOND STAGE
 MSE PANEL ALIGNMENT)

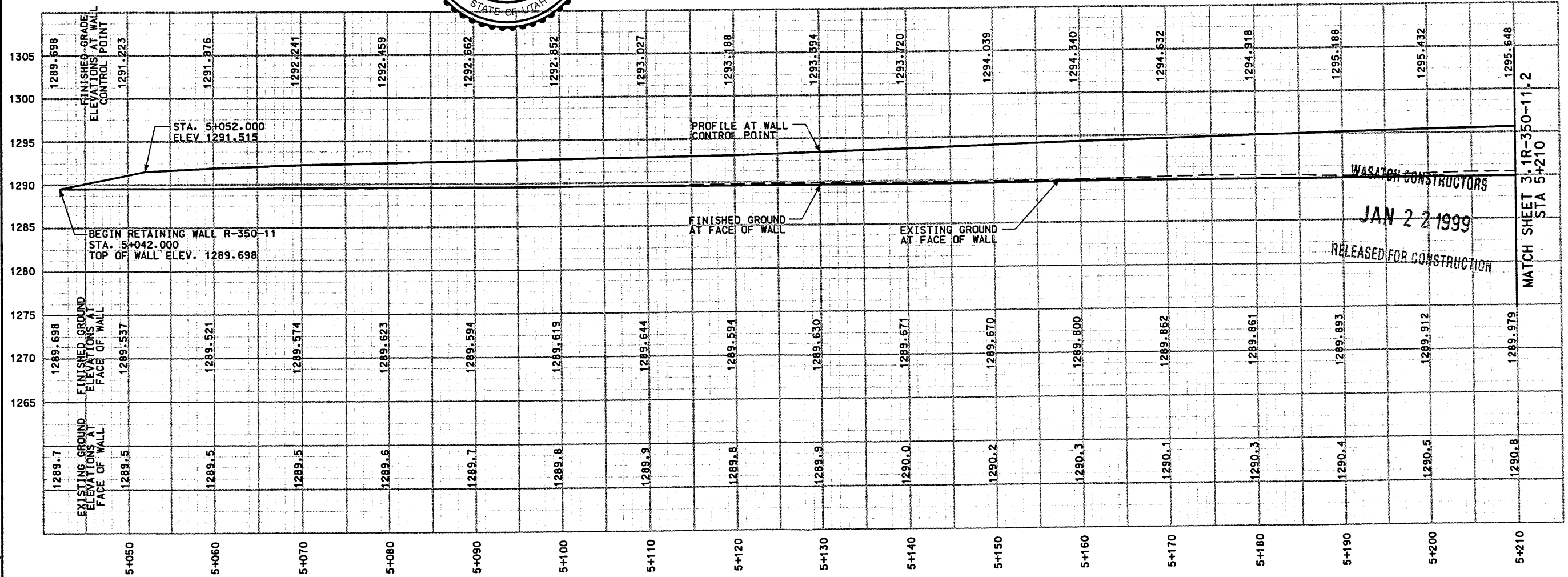
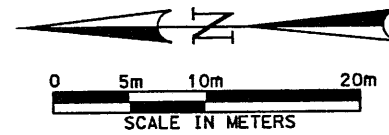

APPROVED FOR CONSTRUCTION		DESCRIPTION	
NO.	DATE	NO.	DATE
1	3/25/98	1	98 EARLY G/D/P
2	4/14/98	2	DESIGN CHANGE
3	5/12/98	3	98 EARLY FINAL ROADWAY
4	1/12/99	4	RELEASE FOR SECOND STAGE CONSTRUCTION ONLY

UTAH DEPARTMENT OF TRANSPORTATION		M/K CENTENNIAL	
SVERDRUP/DE LEUW		WBS NO. 3112408	
DESIGN DMC	7/29/97	CHECK	C.J.O.
DESIGN	8/04/97	PROJECT DESIGN ENGINEER	Bret A. Reynolds
DRAWN	M.V.M.	CHECK	C.J.O.
QUANT.	J.B.W.	CHECK	J.A.B.
DATE	3/17/98	DATE	3/19/98
APPROVED	8/04/97	PROJECT MANAGER	Randle L. Ross
DATE	8/04/97	PROJECT NUMBER	#SP-15-7(135)296

I-15 CORRIDOR RECONSTRUCTION	
SITUATION & LAYOUT R-350-II	
SECTION 3.I	
COUNTY SALT LAKE	
DWG. NO. 3.1R-350-11.1	
SHT. 1	OF 16
REF.	

RFC After Final Approval

Filename: ca:\dgn\15_cadd\13_97\revision_files\walls\03wall-11.dgn

Date: 16-MAY-1998 Time: 15:48

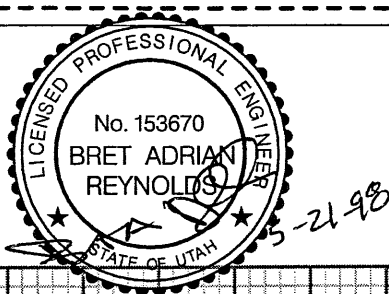
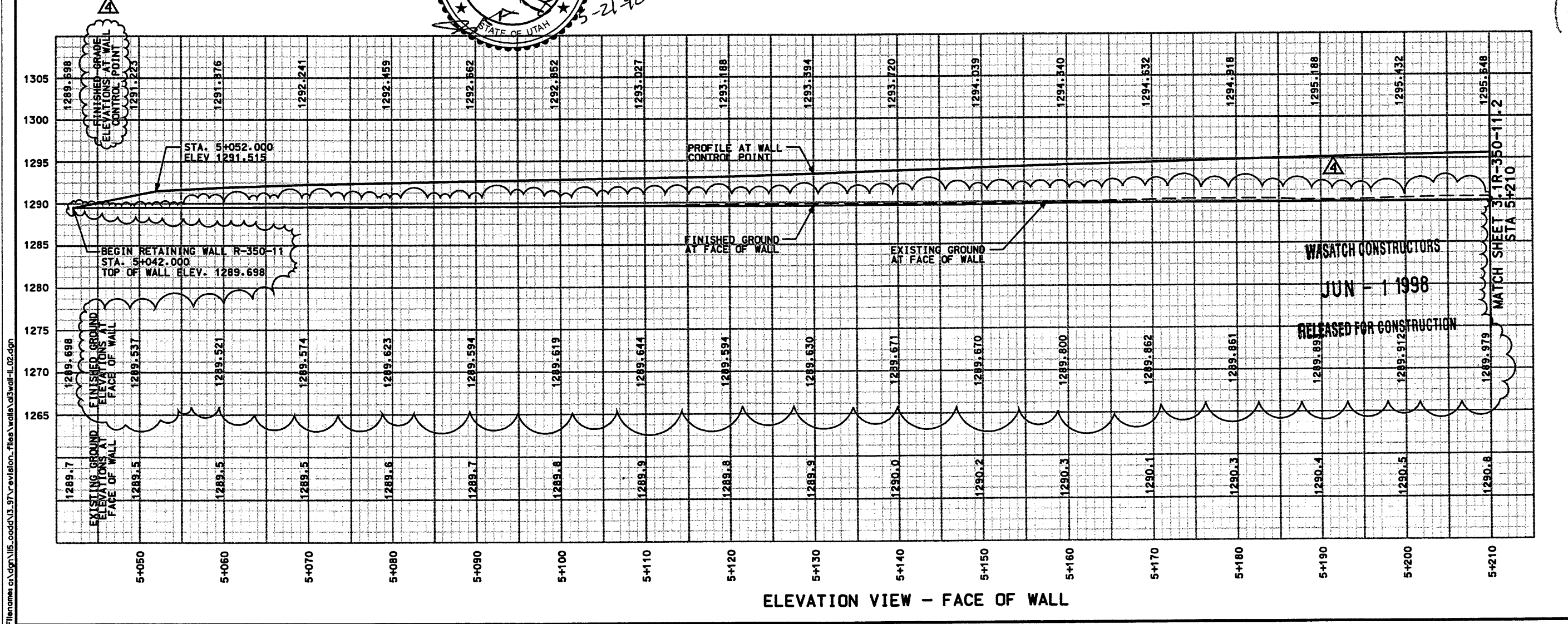

BEGIN RETAINING WALL 3.1R-350-11
 SBCD1 STA 3+409.272, 25.959 RT =
 RETAINING WALL STA 5+042.000
 N = 52664.834
 E = 49953.147

ELEVATION VIEW - FACE OF WALL

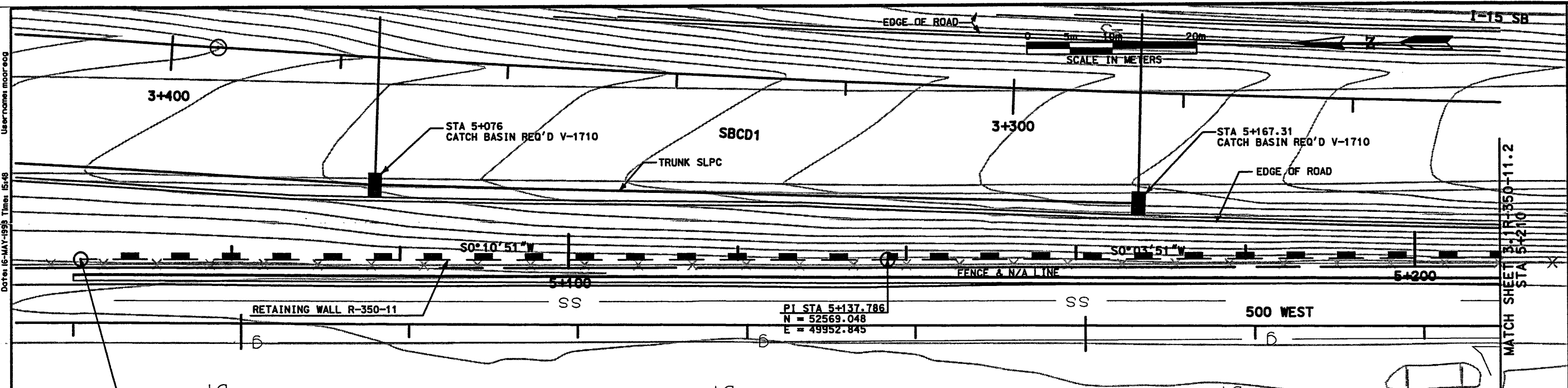

APPROVED FOR CONSTRUCTION	
NO.	DATE
Δ	12/04/97
Δ	3/25/98
Δ	4/14/98
Δ	5/21/98
DESCRIPTION	
ORIGINAL ISSUE	
98 EARLY 60/P	
DESIGN CHANGE	
98 EARLY FINAL ROADWAY	
UTAH DEPARTMENT OF TRANSPORTATION	
MK CENTENNIAL	
SVERDRUP/DE LEUW	
DESIGN DMC	7/29/97
CHECK	CJD
DATE	9/04/97
DESIGN	MMW
CHECK	CJD
DATE	9/04/97
DRAWN	MMW
CHECK	JAB
DATE	3/19/98
QUANT.	JBN
CHECK	JAB
DATE	3/19/98
PROJECT NUMBER	#SP-15-7(135)296
SECTION	SECTION 3J
SITUATION & LAYOUT	R-350-II
RECONSTRUCTION	
SALT LAKE COUNTY	
DWG. NO. 3.1R-350-11.1	
SHT	1 of 16
REF.	

WASATCH CONSTRUCTORS
 JUN - 1 1998
 RELEASED FOR CONSTRUCTION

MATCH SHEET 3.1R-350-11.2
 STA 5+210

Users: ramesh.silmon@h

Date: 12-JUN-1999 Time: 10:24

Filename: c:\dgn\15_cadd\15_97a\fd_99\sheet_1\files\wall\3_rfc\wall-1_02.fdo.dgn

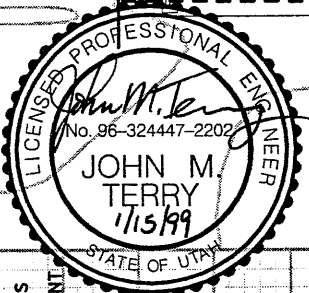
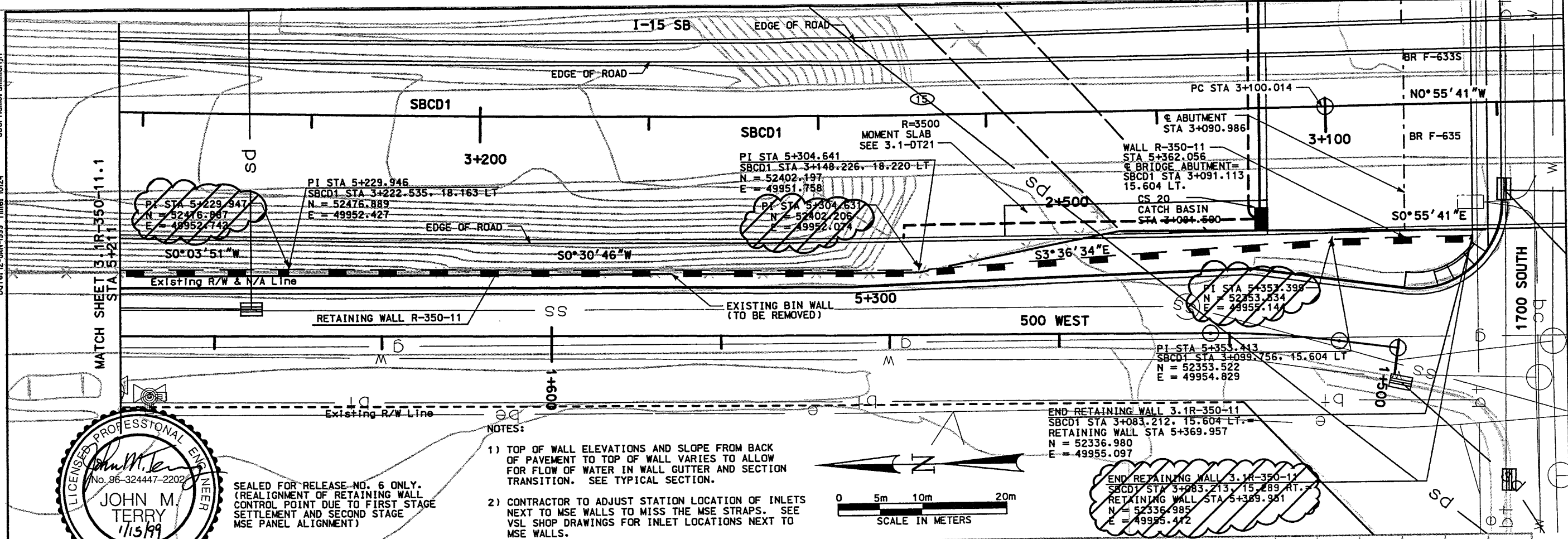

SEALED FOR RELEASE NO. 6 ONLY.
 (REALIGNMENT OF RETAINING WALL
 CONTROL POINT DUE TO FIRST STAGE
 SETTLEMENT AND SECOND STAGE
 MSE PANEL ALIGNMENT)

- NOTES:
- 1) TOP OF WALL ELEVATIONS AND SLOPE FROM BACK OF PAVEMENT TO TOP OF WALL VARIES TO ALLOW FOR FLOW OF WATER IN WALL GUTTER AND SECTION TRANSITION. SEE TYPICAL SECTION.
 - 2) CONTRACTOR TO ADJUST STATION LOCATION OF INLETS NEXT TO MSE WALLS TO MISS THE MSE STRAPS. SEE VSL SHOP DRAWINGS FOR INLET LOCATIONS NEXT TO MSE WALLS.

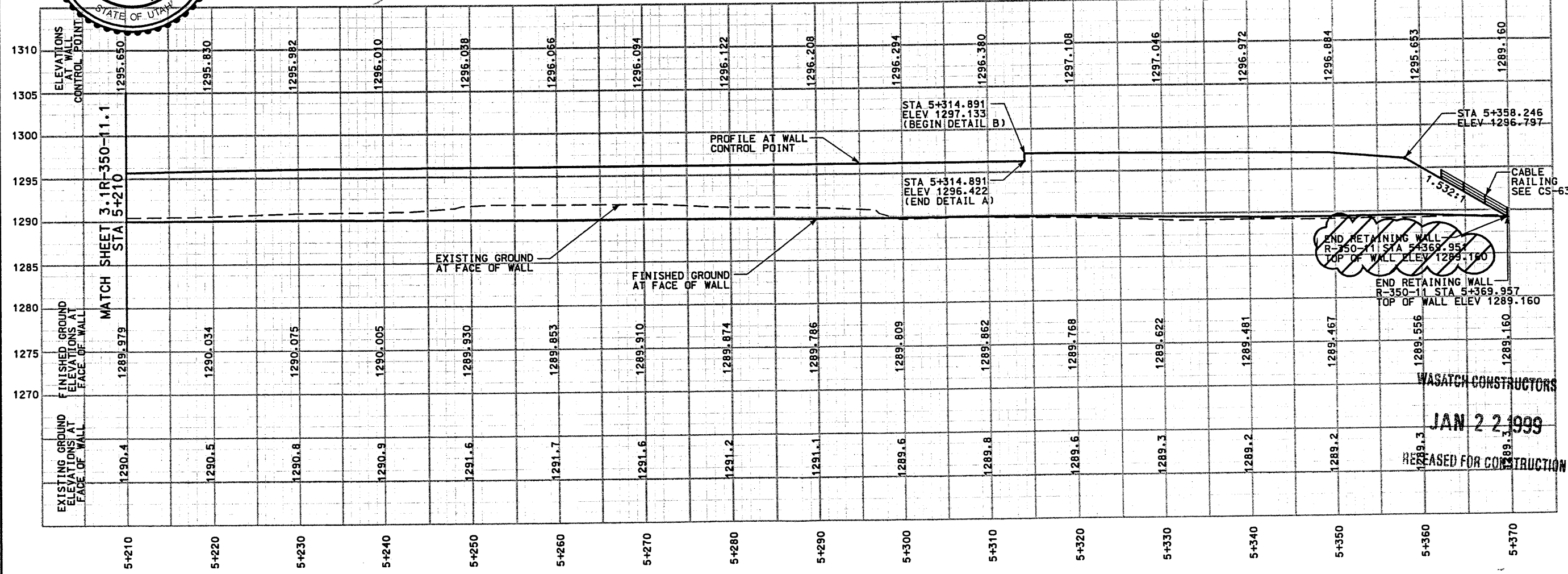
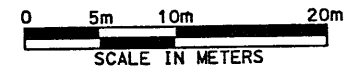

RELEASED FOR CONSTRUCTION
 JAN 22 1999
 WASATCH CONSTRUCTORS

APPROVED FOR CONSTRUCTION

NO.	DATE	DESCRIPTION
1	10/28/98	NOC - 0214
2	01/12/99	RELEASE FOR SECOND STAGE CONSTRUCTION ONLY
3	1/1	1/1
4	1/1	1/1

UTAH DEPARTMENT OF TRANSPORTATION
 MK CENTENNIAL
 SVERDRUP/DE LEW

DESIGN DMC	7/29/97	CHECK	CJO	8/04/97	WBS NO.	3112408
DRAWN	MMW	7/31/97	CHECK	CJO	8/04/97	
QUANT.	JBW	3/17/98	CHECK	JAB	3/19/98	

APPROVAL: 8/04/97, Bret A. Reynolds, PROJECT DESIGN ENGINEER
 APPROVED: 9/01/97, Randle L. Ross, PROJECT MANAGER

I-15 CORRIDOR RECONSTRUCTION
 SITUATION & LAYOUT R-350-II
 SECTION 3.1
 PROJECT NUMBER #SP-15-7(135)296

SALT LAKE COUNTY
 DWG. NO. 3.1R-350-11.2
 SHT 2 OF 16

RFC After Final Approval

Filename: c:\dgn\15_cadd\15_97\sheet_files\wall\3_rctwall_11.02.dgn

Date: 28-OCT-1998 Time: 10:09 User: rones webb

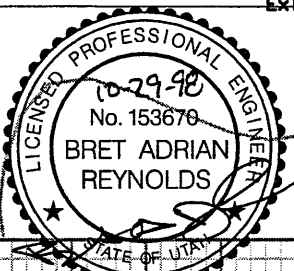
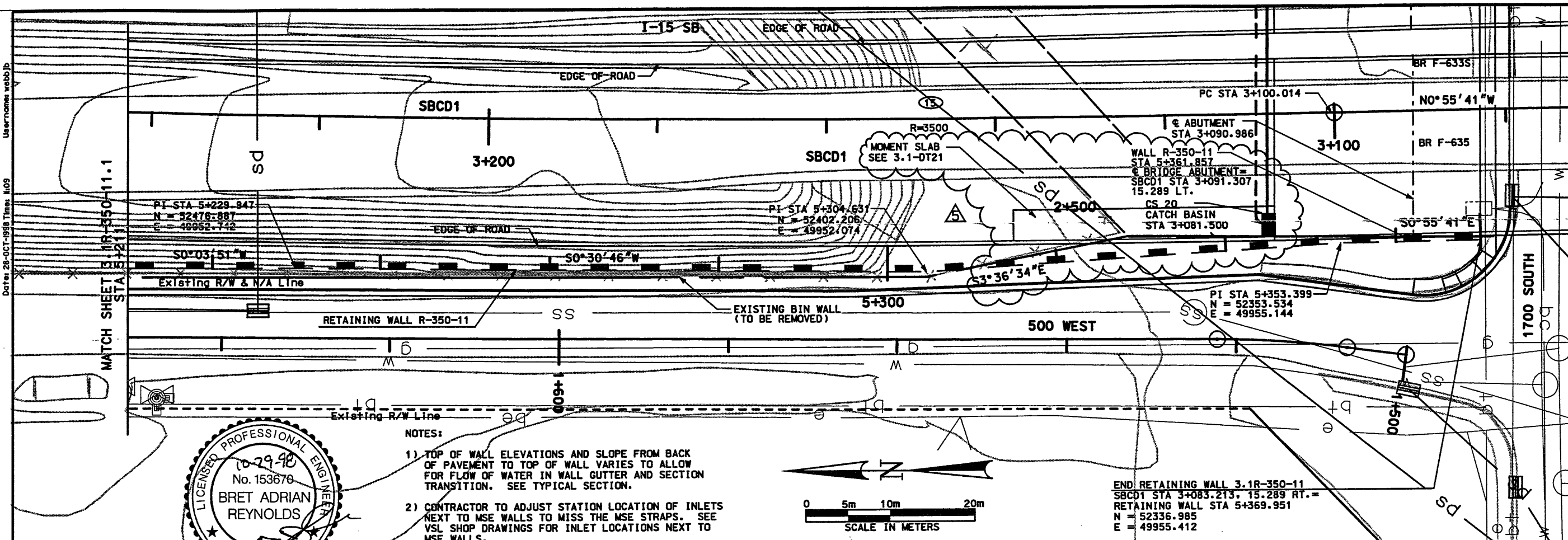

- NOTES:
- 1) TOP OF WALL ELEVATIONS AND SLOPE FROM BACK OF PAVEMENT TO TOP OF WALL VARIES TO ALLOW FOR FLOW OF WATER IN WALL GUTTER AND SECTION TRANSITION. SEE TYPICAL SECTION.
 - 2) CONTRACTOR TO ADJUST STATION LOCATION OF INLETS NEXT TO MSE WALLS TO MISS THE MSE STRAPS. SEE VSL SHOP DRAWINGS FOR INLET LOCATIONS NEXT TO MSE WALLS.

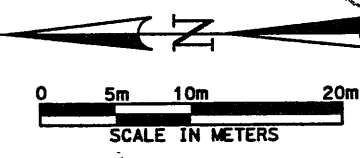

END RETAINING WALL 3.1R-350-11
 SBCD1 STA 3+083.213, 15.289 RT. =
 RETAINING WALL STA 5+369.951
 N = 52336.985
 E = 49955.412

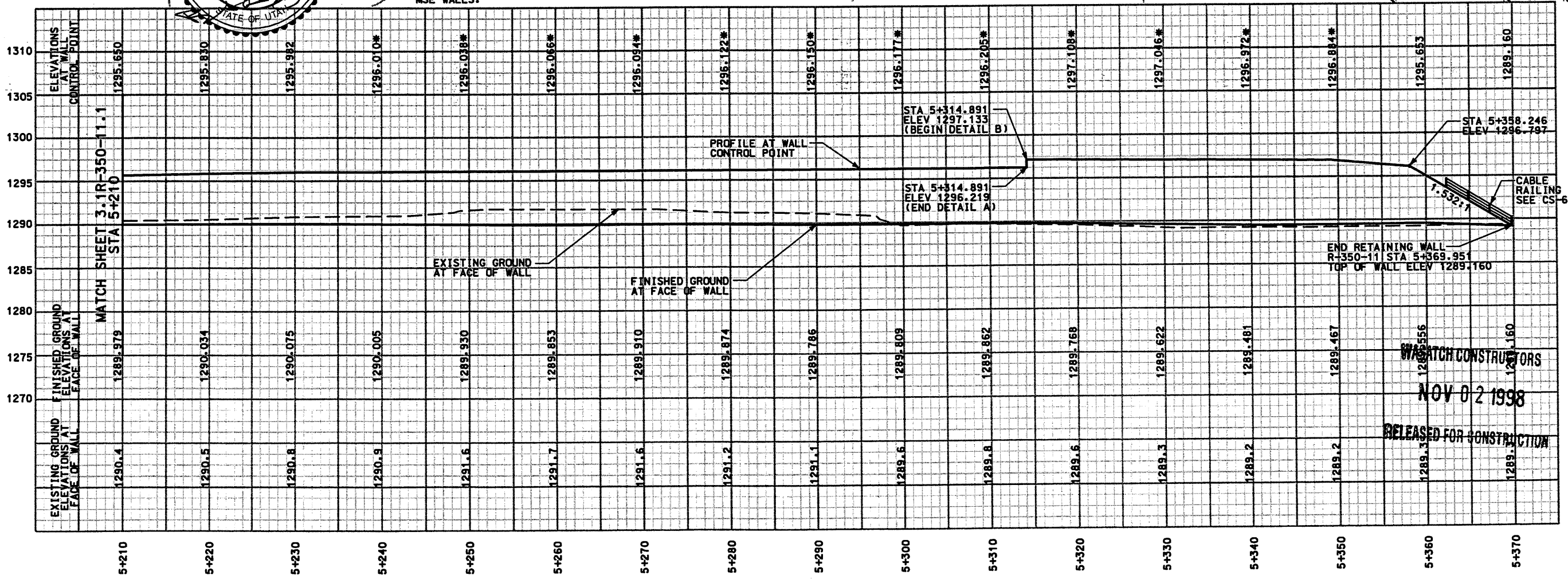

ELEVATION VIEW - FACE OF WALL

RELEASED FOR CONSTRUCTION
 NOV 02 1998
 MATCH CONSTRUCTORS

APPROVED FOR CONSTRUCTION	
NO.	DATE
1	10/28/98
2	11/11/98
3	11/11/98
4	11/11/98
DESCRIPTION	
NOC - 0274	
UTAH DEPARTMENT OF TRANSPORTATION	
MK CENTENNIAL	
SVERDRUP/DE LEUW	
APPROVAL DATE	APPROVAL DATE
8/04/97	8/04/97
Bret A. Reynolds	Randle L. Ross
PROJECT DESIGN ENGINEER	PROJECT MANAGER
REGION DMC	QUANT.
1/29/97	JWB
1/31/97	3/17/98
8/04/97	3/19/98
I-15 CORRIDOR RECONSTRUCTION	
SITUATION & LAYOUT R-350-II	
SECTION 3.1	
PROJECT NUMBER #SP-15-7(135)296	
SALT LAKE COUNTY	
DWG. NO. 3.1R-350-11.2	
SHT. 2 OF 16	
REF.	

RETAINING WALL DETAIL

WALL R-350-11
(2-STAGE MSE WALL)

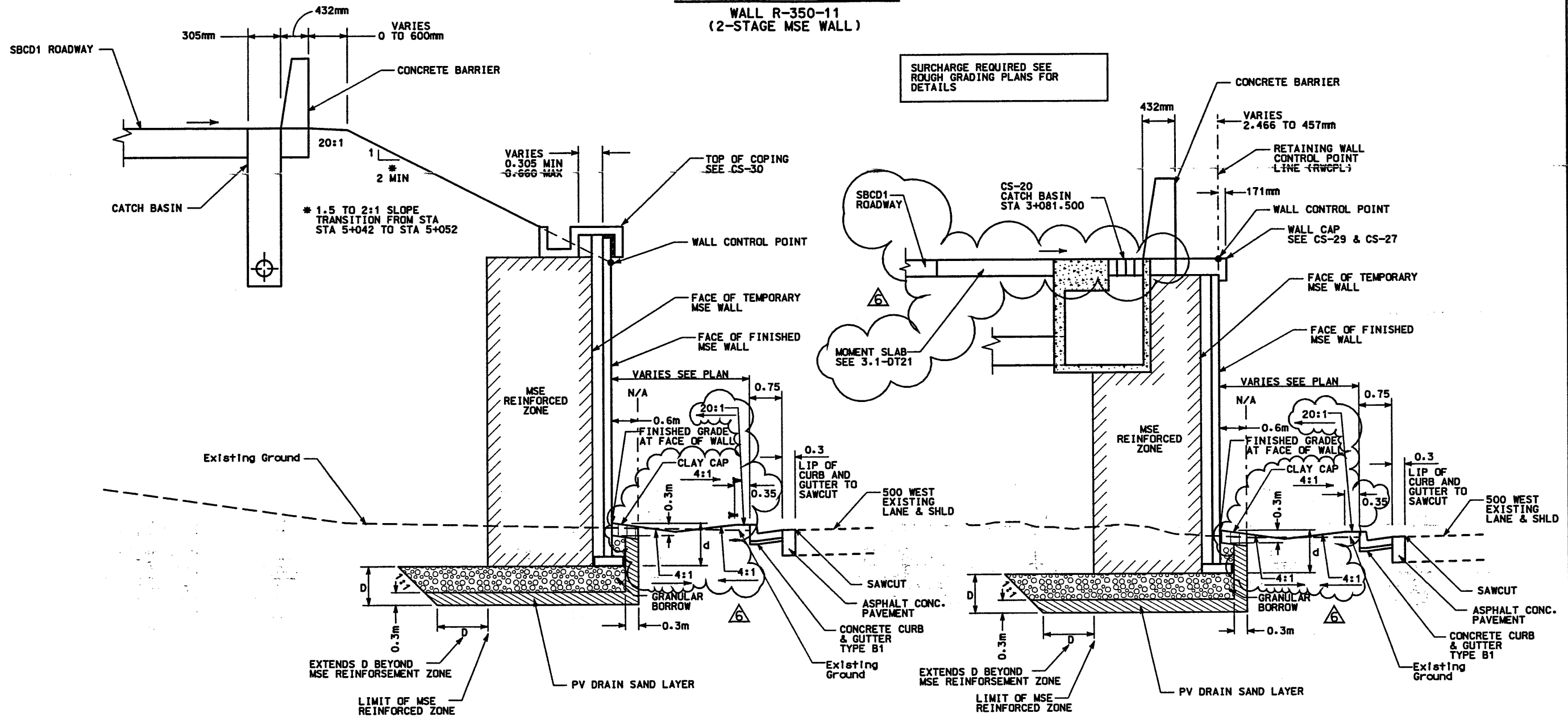

NOTES:

- 1) OVEREXCAVATE EXISTING SOILS TO DEPTH (D) OF 1.0m MINIMUM OR AS SHOWN ON VSL PLANS.
- 2) CONSTRUCT CLAY CAP WITH LOW PLASTIC SILTY CLAY (0.3m THICK) BETWEEN WALL AND N/A LINE.
- 3) SEE CORRIDOR STANDARD SPECIFICATION 221 FOR SPECIAL EXCAVATION REQUIREMENTS WHERE GROUNDWATER IS EXPECTED AT OR ABOVE THE REQUIRED EXCAVATION ELEVATION.
- 4) SEE CORRIDOR STANDARD SPECIFICATION 210 FOR SPECIAL EXCAVATION AND BACKFILL REQUIREMENTS WHERE SOFT CLAYS OR OTHER SOFT AND/OR WET CONDITIONS ARE ENCOUNTERED.
- 5) FOR INFORMATION ONLY. EXISTING STORM DRAIN REPLACEMENT WILL NOT HAPPEN DURING CONSTRUCTION OF WALL R-350-11. SEE DRAINAGE PLANS AND PROFILES FOR ELEVATIONS AND LOCATIONS.
- 6) CONTRACTOR SHALL PROTECT THE WALL WITH TEMPORARY CONCRETE BARRIER AS REQUIRED FOR STAGE CONSTRUCTION OF 500 WEST AND WALL R-350-11.

d = EMBEDMENT DEPTH (SEE VSL DETAILS)
D = DESIGN DEPTH OF STRUCTURAL FILL BENEATH WALL (SEE VSL DETAILS)

DETAIL A
STA 5+042 TO STA 5+314.891

DETAIL B
STA 5+314.891 TO STA 5+358.246

d = EMBEDMENT DEPTH (SEE VSL PLANS)
D = DESIGN DEPTH OF STRUCTURAL FILL BENEATH WALL (SEE VSL PLANS)

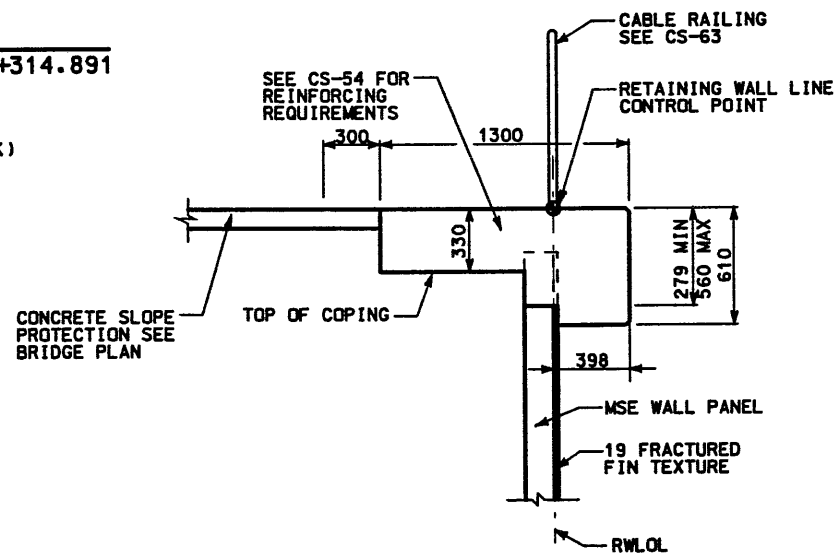

DETAIL C
STA 5+358.246 TO STA 5+369.951
NTS



APPROVED FOR CONSTRUCTION	
NO.	DATE
1	9/30/98
2	10/28/98
3	11/11/98
4	11/11/98

UTAH DEPARTMENT OF TRANSPORTATION	
MK CENTENNIAL	
SVERDRUP/DE LEUW	
DESIGN	CHECK
DMC	7/29/97
MVA	7/31/97
JBW	3/17/98
APPROVAL	DATE
Bret A. Reynolds	8/04/97
PROJECT DESIGN ENGINEER	
Raiddle L. Robb	8/04/97
PROJECT MANAGER	

1-15 CORRIDOR RECONSTRUCTION	
WALL DETAIL R-350-11	
SECTION 3.1	
PROJECT NUMBER #SP-15-7(135)296	
SALT LAKE COUNTY	
DWG. NO. 3.1R-350-11.3	
SHT. 3 OF 16	
REF.	

WASATCH CONSTRUCTORS
NOV 02 1998
RELEASED FOR CONSTRUCTION

Date: 28-OCT-1998 Time: 11:17 User: rames webb\p

Users: ronas webb.jp Date: 28-OCT-1998 Time: 14:20

Filename: g:\dgn\15_cadd\15_s\sheet1_files\vdavis\13_r\retwall_11.04.dgn

RETAINING WALL DETAIL
WALL R-350-11
(2-STAGE MSE WALL)

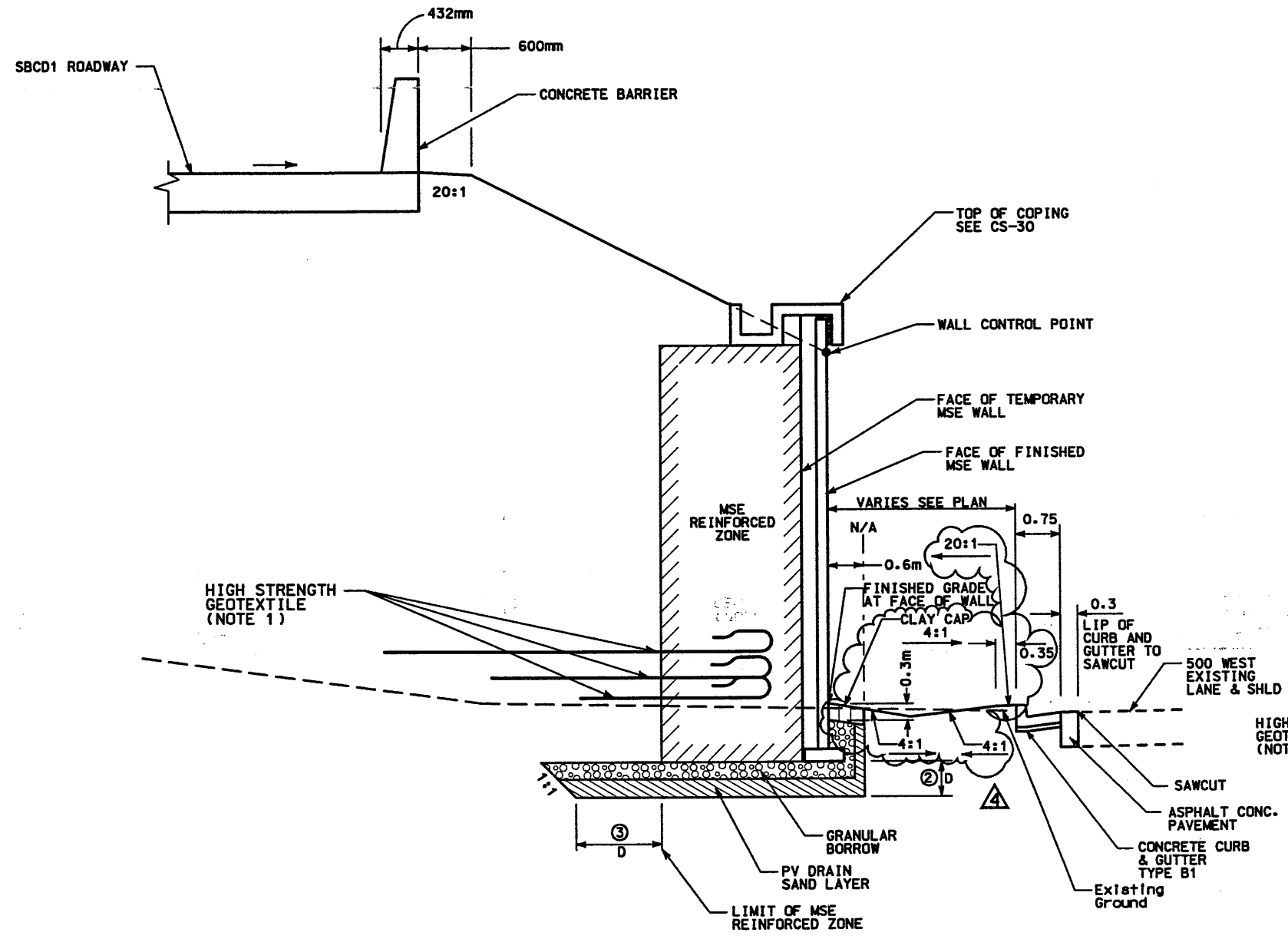

MSE WALL / GEOTEXTILE SCHEMATIC SECTION

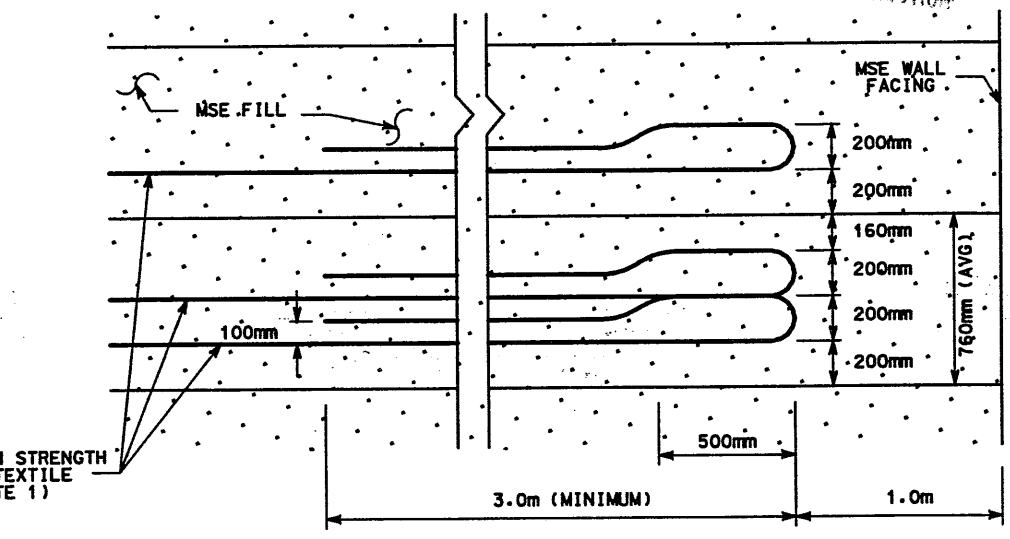
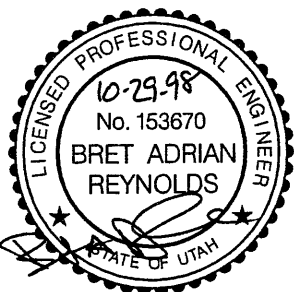

GEOTEXTILE "WRAP AROUND" ANCHORAGE WITHIN MSE WALL

- NOTES:**
- 1) SEE ROUGH GRADING PLANS AND DETAILS FOR ADDITIONAL INFORMATION REGARDING PLACEMENT OF GEOTEXTILE OUTSIDE OF MSE WALL REINFORCEMENT ZONE.
 - 2) THE DEPTH (D) IS AS SHOWN ON WALL DRAWINGS.
 - 3) FROM WALL STA. 5+280 TO 5+308 THE DISTANCE FROM THE BACK OF MSE REINFORCED ZONE TO THE 1:1 SLOPE IS D/2.
 - 4) CONTRACTOR SHALL PROTECT THE WALL WITH TEMPORARY CONCRETE BARRIER AS REQUIRED FOR STAGE CONSTRUCTION OF 500 WEST AND WALL R-350-11.

WASATCH CONSTRUCTORS
NOV 02 1998
RELEASED FOR CONSTRUCTION
WASATCH CONSTRUCTORS
NOV 02 1998
RELEASED FOR CONSTRUCTION

APPROVED FOR CONSTRUCTION		DESCRIPTION	
NO.	DATE	NO.	DATE
1	12/09/97	1	12/09/97
2	3/25/98	2	3/25/98
3	5/21/98	3	5/21/98
4	10/28/98	4	10/28/98
UTAH DEPARTMENT OF TRANSPORTATION		WBS NO. 3112800	
MK CENTENNIAL SVDRUP/DE LEUW		DESIGN C/JD 8/04/97	
Bret A. Reynolds		CHECK C/JD 7/29/97	
PROJECT DESIGN ENGINEER		DRAW M/M 7/29/97	
8/04/97		QUANT. J/W 3/17/98	
DATE		CHECK C/JD 3/19/98	
APPROVED 8/04/97		DATE	
DATE		DATE	
I-15 CORRIDOR RECONSTRUCTION		SECTION 3.1	
WALL DETAIL R-350-11		#SP-15-7 (135)296	
COUNTY		PROJECT NUMBER	
SALT LAKE			
DWG. NO.			
3.1R-350-11.4			
SHT. 4 OF 16			
REF.			

REFERENCE (X-UTM.DWG)

H:\RE_EARTH\PROJECT\239-0007\13SERIES\13-111\SUBMITL-4\RE-1

FINAL PLOT 12-18-98

NOTE:
 BACKFILL THE WALL GAP TO AN ELEVATION EQUAL TO 1.5m ABOVE FINISHED GRADE DUE TO THE POTENTIAL FOR TRAFFIC IMPACT ON THE PRECAST WALL PANELS FROM THE ADJACENT ROADWAY. SEE VSL STANDARD DRAWING STD-20 FOR ADDITIONAL DETAILS.

APPROVED FOR CONSTRUCTION		
NO.	DATE	DESCRIPTION
△	12-02-97	RELEASE FOR 1ST STAGE CONST. ONLY
△	12-17-98	RELEASE FOR 2ND. STAGE CONST.

BRIDGE
(BR F-635)

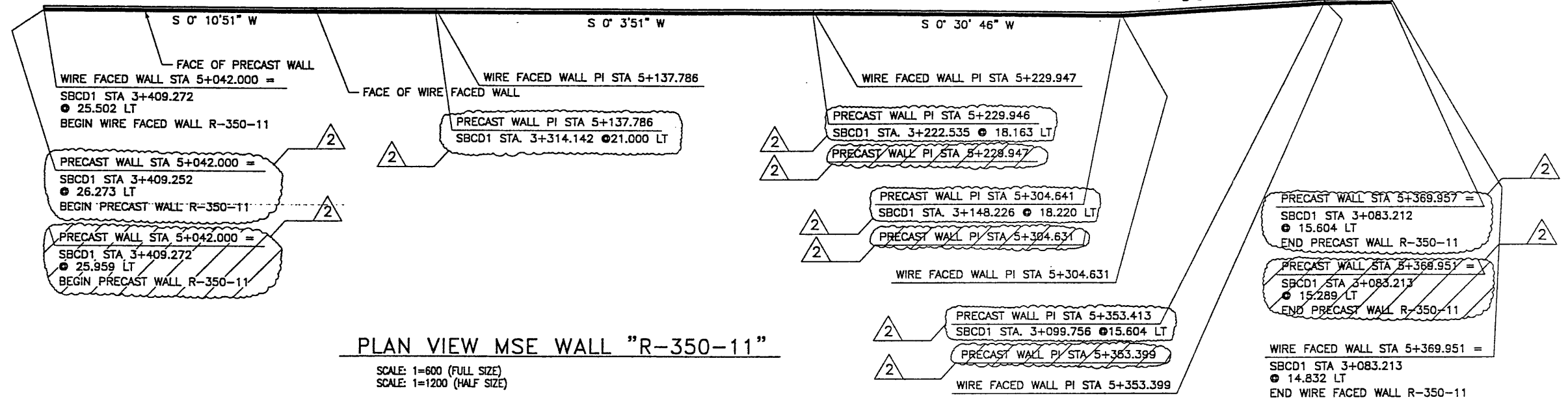
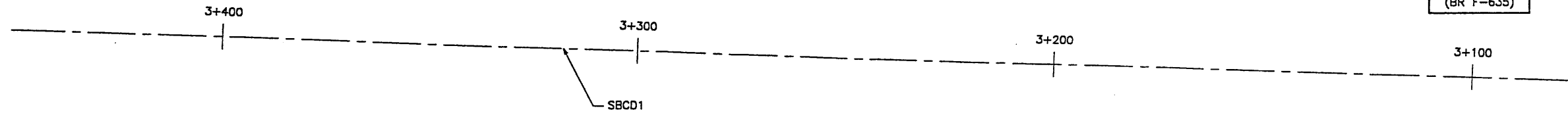

PLAN VIEW MSE WALL "R-350-11"

SCALE: 1=600 (FULL SIZE)
 SCALE: 1=1200 (HALF SIZE)

NOTE:
 THE WALL CONNECTIONS ON WALL 350-11 MAY BE ROTATED A MAXIMUM OF 42° VERTICALLY (COL 116-122) AND 55° VERTICALLY (COL 15-115). SEE DETAIL "SECTION ROTATED" ON VSL STANDARD DRAWING NO. 18 FOR MORE INFORMATION.

2ND STAGE DESIGN
 BASED ON POST SETTLEMENT SURVEY OF THE WIRE FACE, LATERAL OUT WARD DISPLACEMENTS RANGED FROM 83mm TO 272mm MEASURED AT THE BASE OF THE WALL.

DESIGN PARAMETERS	
ANGLE OF INTERNAL FRICTION (SELECT) = 34°	
ANGLE OF INTERNAL FRICTION (BASE) = 30°	
ANGLE OF INTERNAL FRICTION (RANDOM) = 34°	
UNIT WEIGHT BACKFILL = 135 PCF. (21.2 KN/M ³)	
TRAFFIC SURCHARGE = 250 PSF	
SEISMIC ACCELERATION COFF. = 0.27g (TYP)	
SEISMIC ACCELERATION COFF. = 0.68g (AT BRIDGE ABUTMENTS)	
DESIGN CRITERIA	
SAFETY FACTOR (OVERTURNING) = 2.0	
SAFETY FACTOR (SLIDING) = 1.5	
SAFETY FACTOR (PULLOUT) = 1.5	
DESIGN LIFE = 75 YEARS	

RETAINED EARTH INDEX	
RE-1	PLAN WIRE FACED WALL R-350-11, NOTES & DESIGN CRITERIA
RE-2	WALL CONNECTION DETAILS @ STAGE CONST.
RE-3	TYPICAL DETAILS
RE-4	TYPICAL CROSS SECTIONS @ WIRE FACED WALL
RE-5	TYPICAL CROSS SECTION
RE-6	WIRE FACED WALL R-350-11
RE-7	WIRE FACED WALL R-350-11
RE-8	WIRE FACED WALL R-350-11
RE-9	WIRE FACED WALL R-350-11
RE-10	WIRE FACED WALL R-350-11
RE-11	WIRE FACED WALL R-350-11
RE-12	TYPICAL CROSS SECTIONS
RE-13	WALL R-350-11 - 2ND STAGE PRECAST WALL
RE-14	WALL R-350-11 - 2ND STAGE PRECAST WALL
RE-15	WALL R-350-11 - 2ND STAGE PRECAST WALL
RE-16	SPECIAL PANEL DETAILS
RE-17	SPECIAL PANEL DETAILS
RE-18	SPECIAL PANEL DETAILS

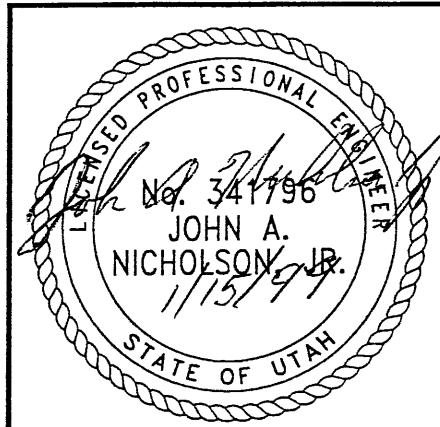

CERTIFIED FOR INTERNAL STABILITY OF RETAINED EARTH™ STRUCTURES ONLY. EXTERNAL STABILITY, INCLUDING BUT NOT LIMITED TO FOUNDATION AND SLOPE STABILITY, IS THE RESPONSIBILITY OF THE OWNER. DESIGN IS BASED ON THE ASSUMPTION THAT THE MATERIAL WITHIN THE RETAINED EARTH™ MASS, METHODS OF CONSTRUCTION, AND QUALITY OF PREFABRICATED MATERIALS CONFORM TO THE MANUFACTURER'S SPECIFICATION.

METRIC

NO.	DATE	DESCRIPTION	NO.	DATE	BY
△	12-02-97	RELEASE FOR 1ST STAGE CONST. ONLY			
△	12-17-98	RELEASE FOR 2ND. STAGE CONST.			

NO.	DATE	BY	REVISION

RETAINED EARTH™ WALLS
 PLAN VIEW MSE WALL "R-350-11"
 UTAH I-15 INTERCHANGE
 SALT LAKE COUNTY, UTAH
 UTAH DEPARTMENT OF TRANSP.

DWG. NO.
3.1R-350-11.5

JOB NO.
239-0007

SHT. NO.
RE-1

VSL CORPORATION
 2610 Piedmont Place, Suite 200
 Raleigh, NC 27607-7818
 Telephone: (919) 701-1680
 Fax: (919) 701-1685

ATLANTA, GA / DALLAS, TX / RALEIGH, NC (CORPORATE OFFICE)
 MAUMEE, OH / SAN JOSE, CA / SPRINGFIELD, VA

WASATCH CONSTRUCTOR
 JAN 22 1999
 RELEASED FOR CONSTRUCTION

RFC After Final Approval

H:\RE_EARTH\PROJECT\239-0007\13SERIES\SUBMITL-4\RE-1 FINAL PL 2-02-97

APPROVED FOR CONSTRUCTION		
NO.	DATE	DESCRIPTION
△	12-02-97	RELEASE FOR 1ST STAGE CONST. ONLY <i>OL</i>

BRIDGE
(BR F-635)

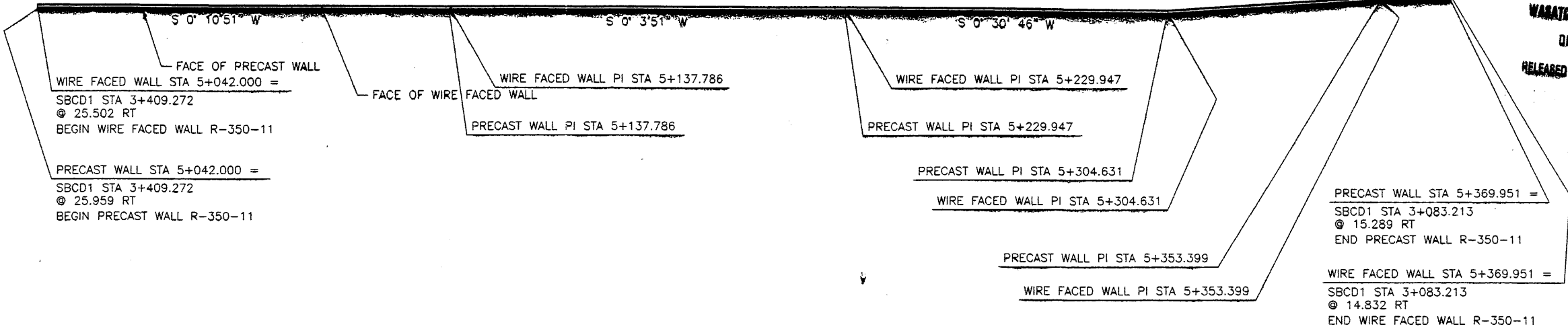
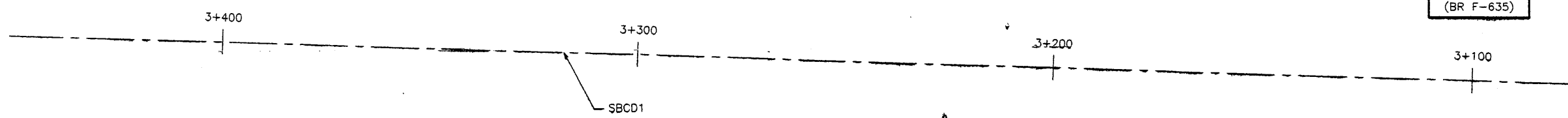

WARATCH CONSTRUCTORS
DEC 10 1997
RELEASED FOR CONSTRUCTION

PLAN VIEW MSE WALL "R-350-11"

SCALE: 1=600 (FULL SIZE)
SCALE: 1=1200 (HALF SIZE)

DESIGN PARAMETERS
ANGLE OF INTERNAL FRICTION (SELECT) = 34°
ANGLE OF INTERNAL FRICTION (BASE) = 30°
ANGLE OF INTERNAL FRICTION (RANDOM) = 34°
UNIT WEIGHT BACKFILL = 135 PCF. (21.2 KN/M ³)
TRAFFIC SURCHARGE = 250 PSF
SEISMIC ACCELERATION COFF. = 0.27g (TYP)
SEISMIC ACCELERATION COFF. = 0.68g (AT BRIDGE ABUTMENTS)
DESIGN CRITERIA
SAFETY FACTOR (OVERTURNING) = 2.0
SAFETY FACTOR (SLIDING) = 1.5
SAFETY FACTOR (PULLOUT) = 1.5
DESIGN LIFE = 75 YEARS

RETAINED EARTH INDEX
RE-1 PLAN WIRE FACED WALL R-350-11, NOTES & DESIGN CRITERIA
RE-2 WALL CONNECTION DETAILS @ STAGE CONST.
RE-3 TYPICAL DETAILS
RE-4 TYPICAL CROSS SECTIONS @ WIRE FACED WALL
RE-5 TYPICAL CROSS SECTION
RE-6 WIRE FACED WALL R-350-11
RE-7 WIRE FACED WALL R-350-11
RE-8 WIRE FACED WALL R-350-11
RE-9 WIRE FACED WALL R-350-11
RE-10 WIRE FACED WALL R-350-11
RE-11 WIRE FACED WALL R-350-11
RE-12 TYPICAL CROSS SECTIONS

SHT 50F16
METRIC

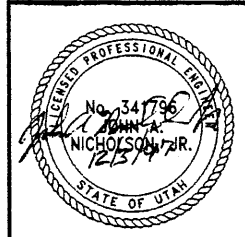

CERTIFIED FOR INTERNAL STABILITY OF RETAINED EARTH™ STRUCTURES ONLY. EXTERNAL STABILITY, INCLUDING BUT NOT LIMITED TO FOUNDATION AND SLOPE STABILITY, IS THE RESPONSIBILITY OF THE OWNER. DESIGN IS BASED ON THE ASSUMPTION THAT THE MATERIAL WITHIN THE RETAINED EARTH™ MASS, METHODS OF CONSTRUCTION, AND QUALITY OF PREFABRICATED MATERIALS CONFORM TO THE MANUFACTURER'S SPECIFICATION.

NO.	DATE	REVISION	BY	CHK

DES. 09-22-97	MM
DRN. 09-22-97	DDO
CHK. 09-22-97	MM

VSL CORPORATION
2840 Plaza Place, Suite 200
Raleigh, NC 27612
Telephone: (919) 781-6272
Fax: (919) 781-4969

VSL
ATLANTA, GA / DALLAS, TX / FALCON, NC (CORPORATE OFFICE)
MIAMI, FL / SAN JOSE, CA / SPRINGFIELD, VA

RETAINED EARTH™ WALLS
PLAN VIEW MSE WALL "R-350-11"
UTAH I-15 INTERCHANGE
SALT LAKE COUNTY, UTAH
UTAH DEPARTMENT OF TRANSP.

SCALE:	3.1R-350-11.5
JOB NO.:	239-0007
	RE-1

H:\RE_EARTH\PROJECT\239-0007\13SERIES\SUBMITL-4\RE-2

FINAL PL -02-97

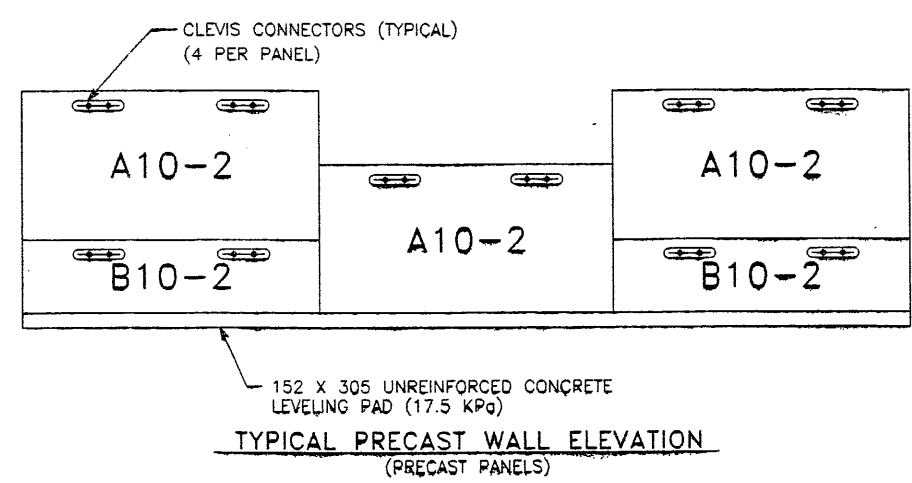
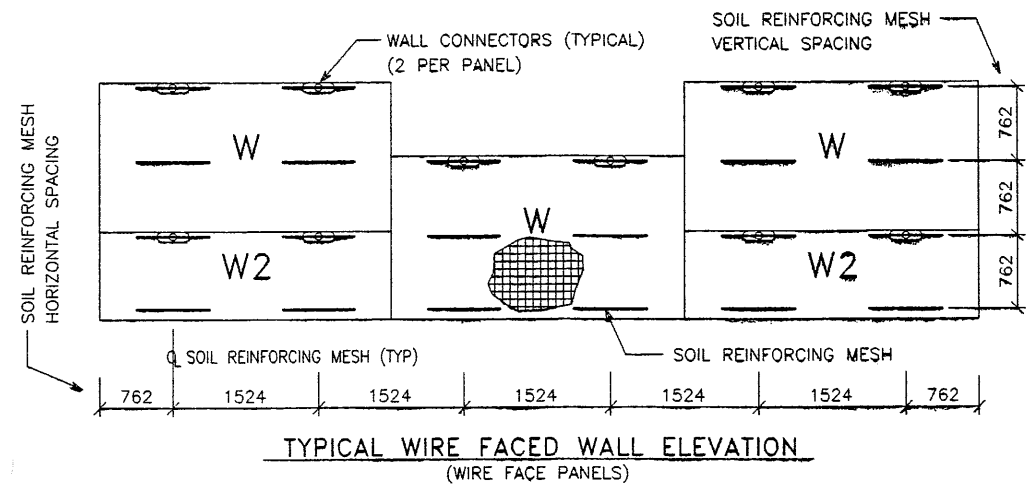
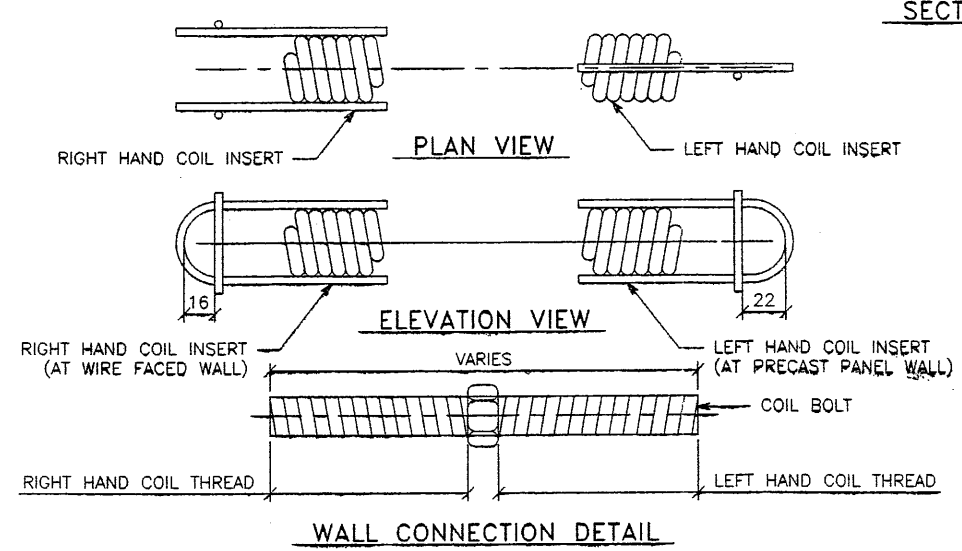
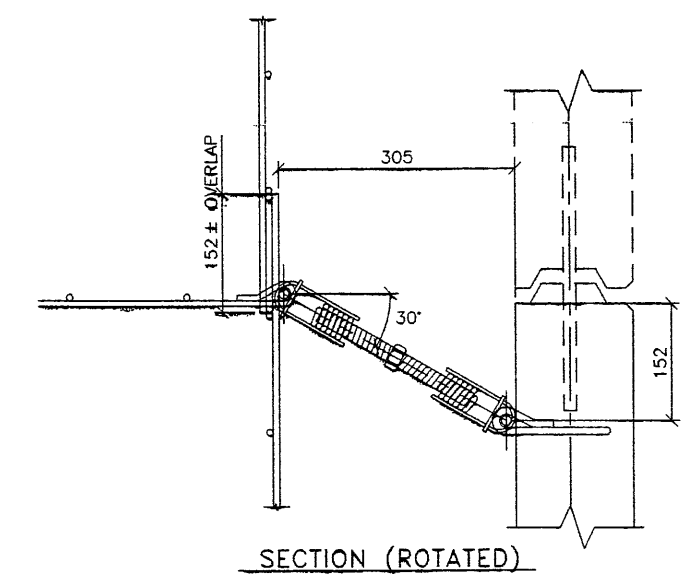
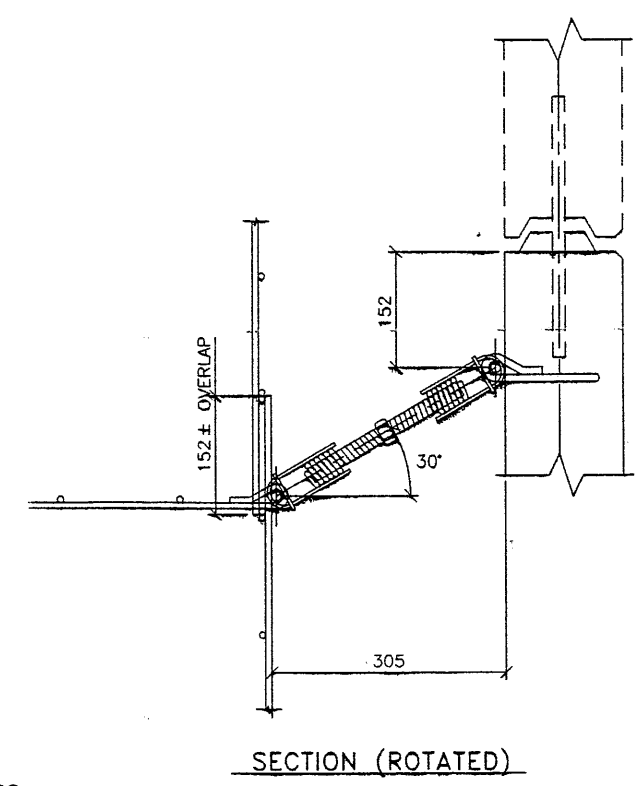
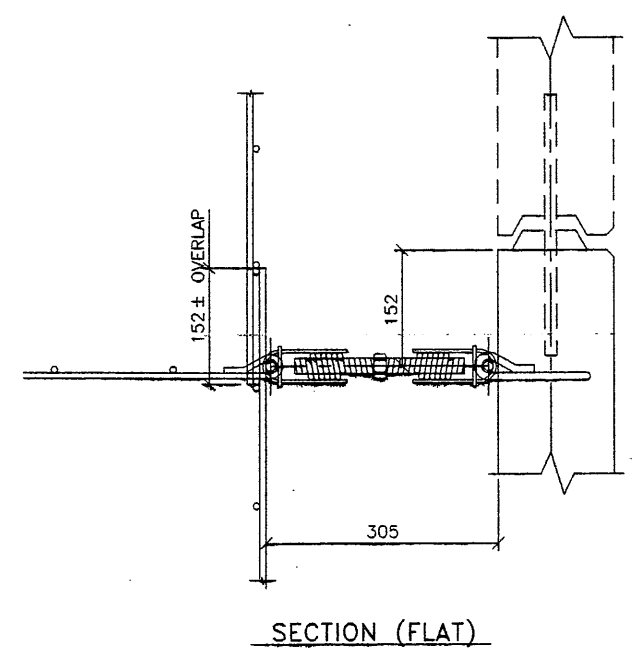
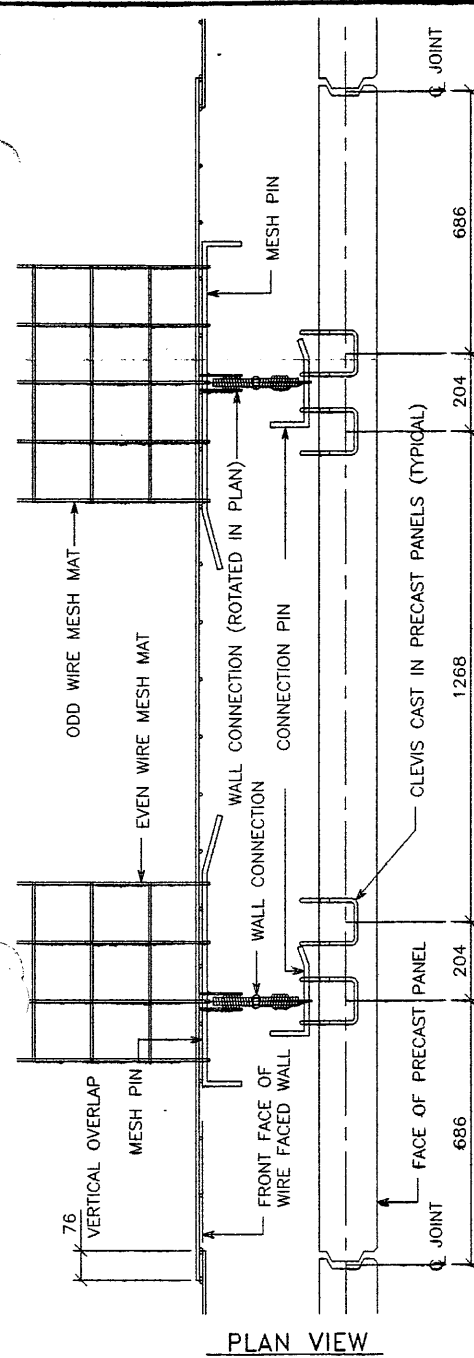

APPROVED FOR CONSTRUCTION		
NO.	DATE	DESCRIPTION
△	12-02-97	RELEASE FOR 1ST STAGE CONST. ONLY ✓

WARATCH CONSTRUCTORS
DEC 10 1997
RELEASED FOR CONSTRUCTION

DES.	09-22-97	MM	NO.		BY	CHK
DRN.	09-22-97	DDO	NO.			
CHK.	09-22-97	MM	NO.			
RETAINED EARTH™						
<p>VSL CORPORATION 2840 Pitts Place, Suite 200 Raleigh, NC 27612 781-6272 Telephone: (919) 781-6272 Fax: (919) 781-4869</p> <p>ATLANTA, GA / DALLAS, TX / RALEIGH, NC (CORPORATE OFFICE) MIAMI, FL / SAN JOSE, CA / SPRINGFIELD, VA</p>						
<p>RETAINED EARTH™ WALLS WIRE FACED WALL "R-350-11" WALL CONNECTION DETAILS @ STAGE CONST.</p> <p>UTAH 1-15 INTERCHANGE SALT LAKE COUNTY, UTAH UTAH DEPARTMENT OF TRANSP.</p>						
<p>SCALE: 3.1R-350-11.6</p> <p>JOB NO: 239-0007</p> <p>RE-2</p>						

CERTIFIED FOR INTERNAL STABILITY OF RETAINED EARTH™ STRUCTURES ONLY. EXTERNAL STABILITY, INCLUDING BUT NOT LIMITED TO FOUNDATION AND SLOPE STABILITY, IS THE RESPONSIBILITY OF THE OWNER. DESIGN IS BASED ON THE ASSUMPTION THAT THE MATERIAL WITHIN THE RETAINED EARTH™ MASS, METHODS OF CONSTRUCTION, AND QUALITY OF PREFABRICATED MATERIALS CONFORM TO THE MANUFACTURER'S SPECIFICATION.

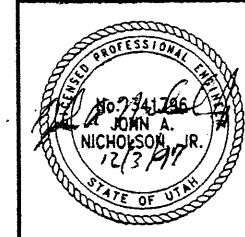

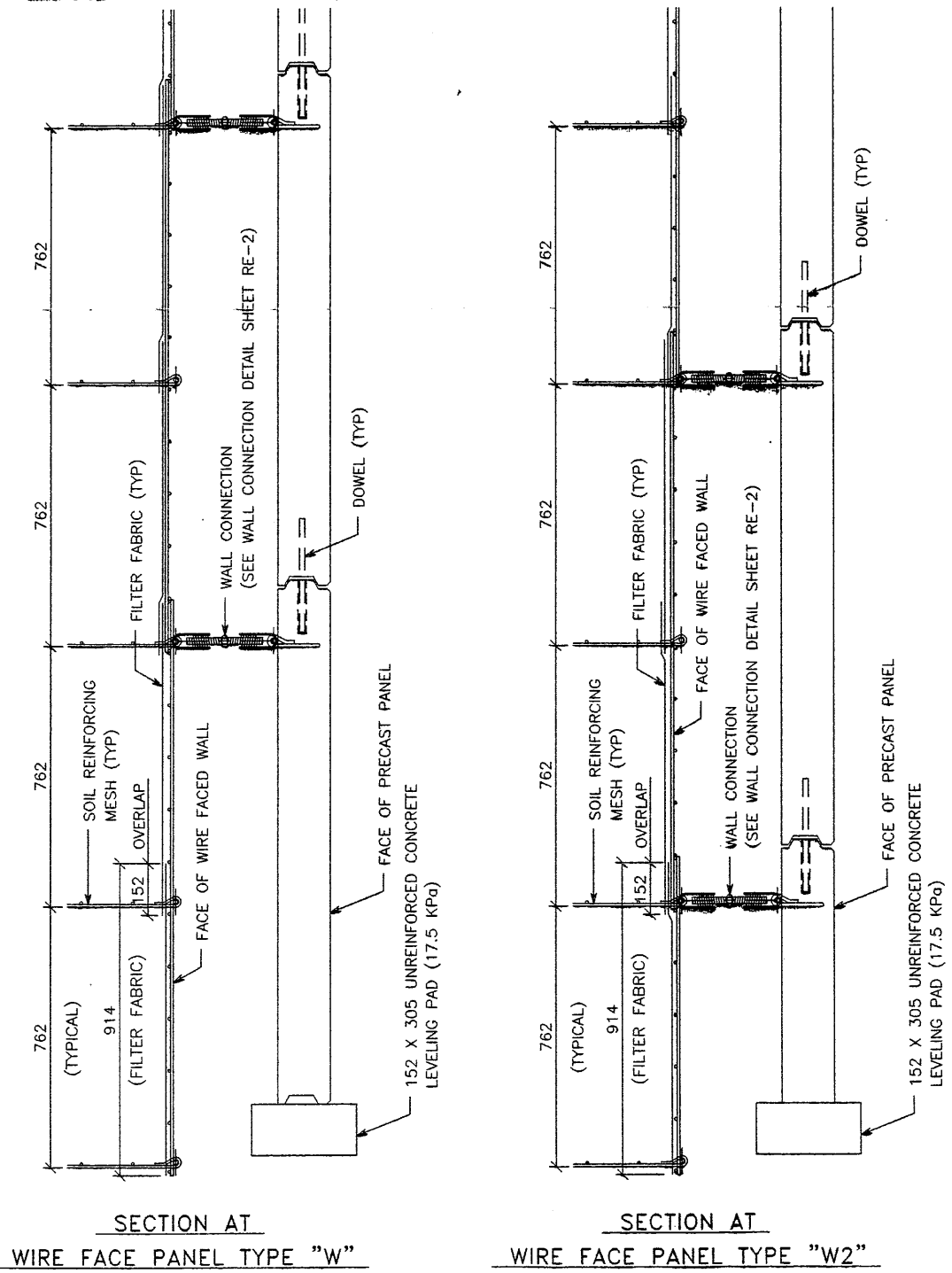

SECTION AT WIRE FACE PANEL TYPE "W"

SECTION AT WIRE FACE PANEL TYPE "W2"

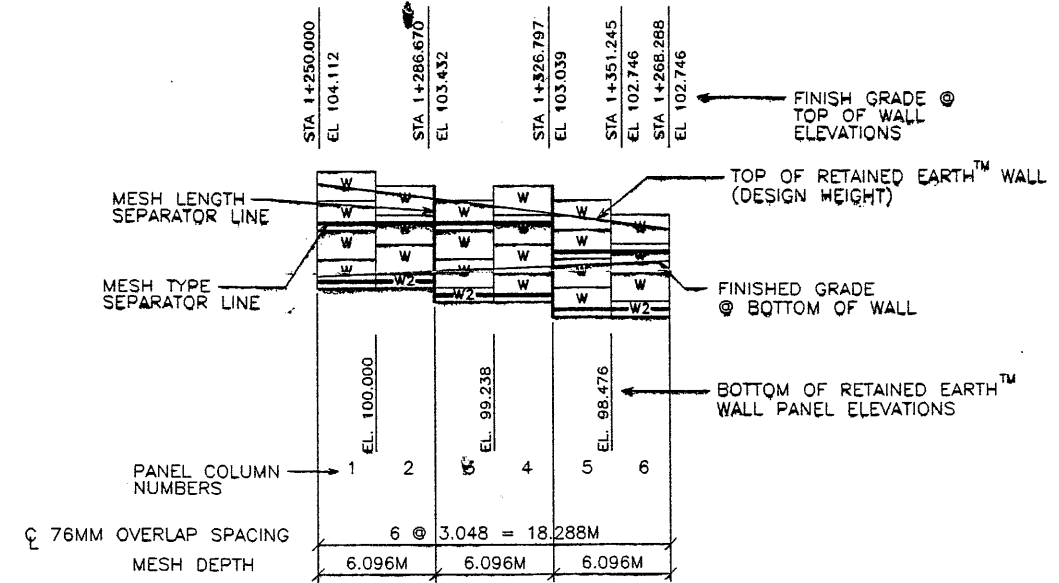
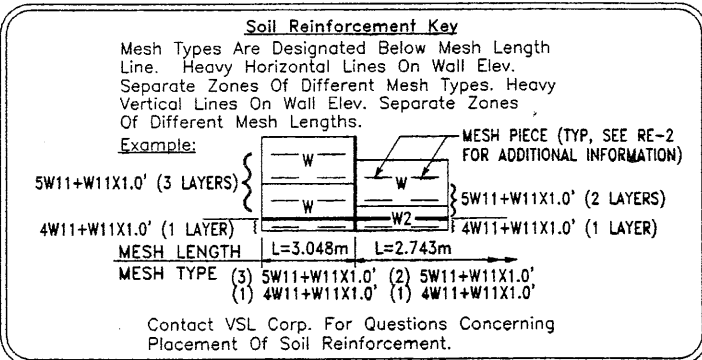

1 WIRE FACED WALL ELEVATION KEY (FRONT FACE SHOWN)

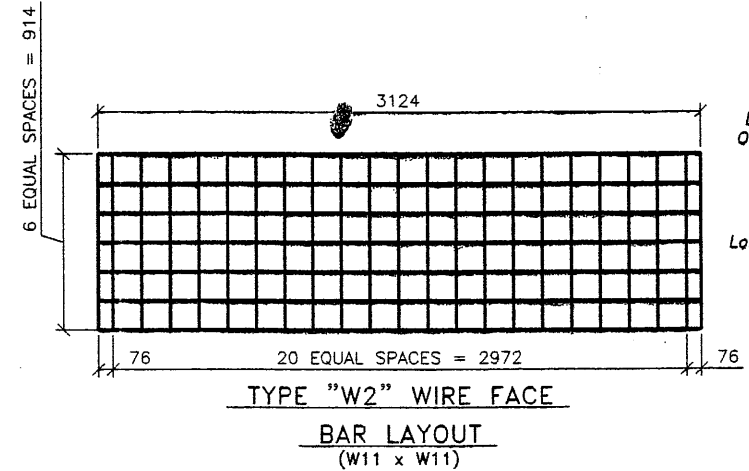

TYPE "W2" WIRE FACE BAR LAYOUT (W11 x W11)

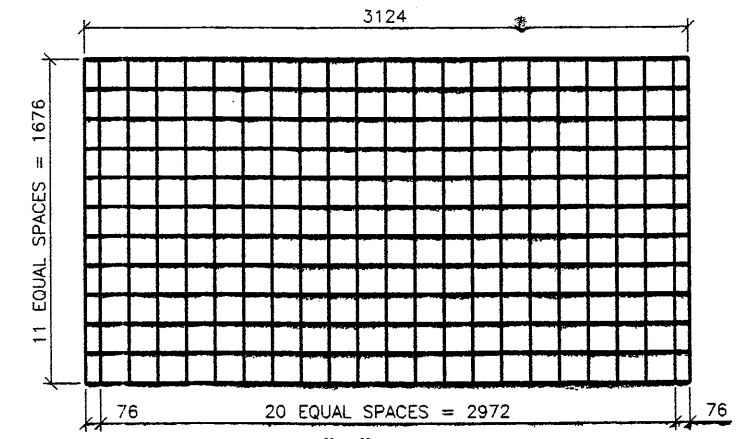

TYPE "W" WIRE FACE BAR LAYOUT (W11 x W11)

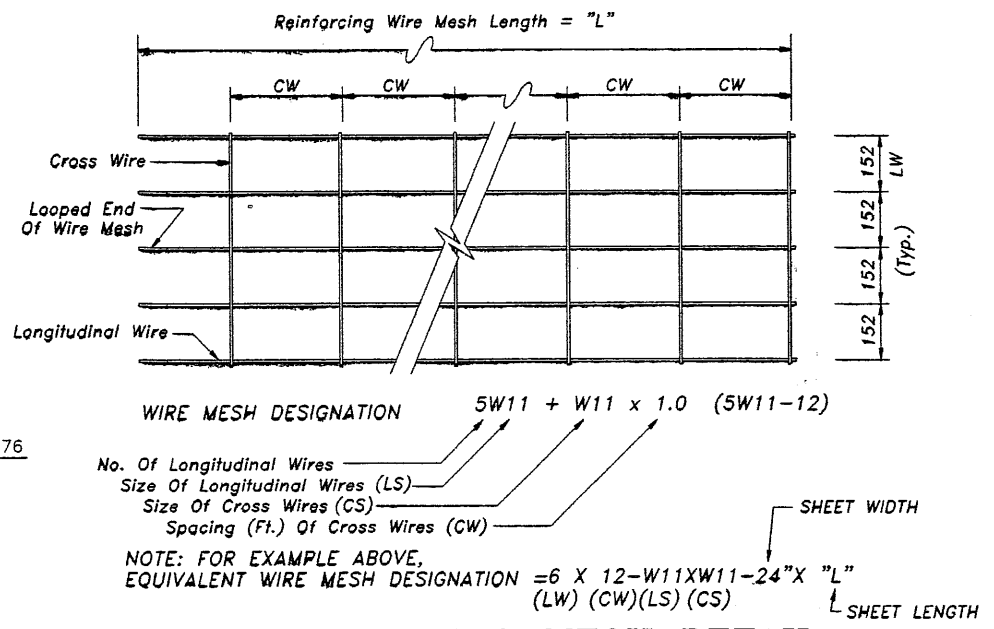

REINFORCING MESH DETAIL

NOTE: W11 (71 sq mm) And W20 (129 sq mm) Steel Wire Material And Welding Of Cross Wires And Loops Shall Conform To ASTM A82 And ASTM 185, Fy = 448 MPa. Mesh Shall Be Galvanized To ASTM A-123 To A Minimum Effective Thickness Of 0.086 mm.

SHT 70F16 METRIC

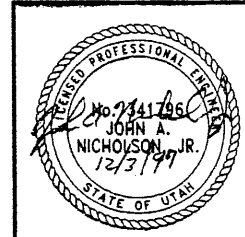

CERTIFIED FOR INTERNAL STABILITY OF RETAINED EARTH™ STRUCTURES ONLY. EXTERNAL STABILITY, INCLUDING BUT NOT LIMITED TO FOUNDATION AND SLOPE STABILITY, IS THE RESPONSIBILITY OF THE OWNER. DESIGN IS BASED ON THE ASSUMPTION THAT THE MATERIAL WITHIN THE RETAINED EARTH™ MASS, METHODS OF CONSTRUCTION, AND QUALITY OF PREFABRICATED MATERIALS CONFORM TO THE MANUFACTURER'S SPECIFICATION.

APPROVED FOR CONSTRUCTION		
NO.	DATE	DESCRIPTION
△	12-02-97	RELEASE FOR 1ST STAGE CONST. ONLY

DES.	09-22-97	MM	VSL CORPORATION 2840 Plaza Place, Suite 200 Raleigh, NC 27612 Telephone: (919) 781-6272 Fac: (919) 781-4869	ATLANTA, GA / DALLAS, TX / RALEIGH, NC (CORPORATE OFFICE) MIAMI, FL / SAN JOSE, CA / SPRINGFIELD, VA	NO.		DATE		REVISION		BY	CHK	
DRN.	09-22-97	DDO											
CHK.	09-22-97	MM											

UTAH I-15 INTERCHANGE
SALT LAKE COUNTY, UTAH
UTAH DEPARTMENT OF TRANSP.

SCALE: 3.1R-350-11.7
JOB NO: 239-0007
RE-3

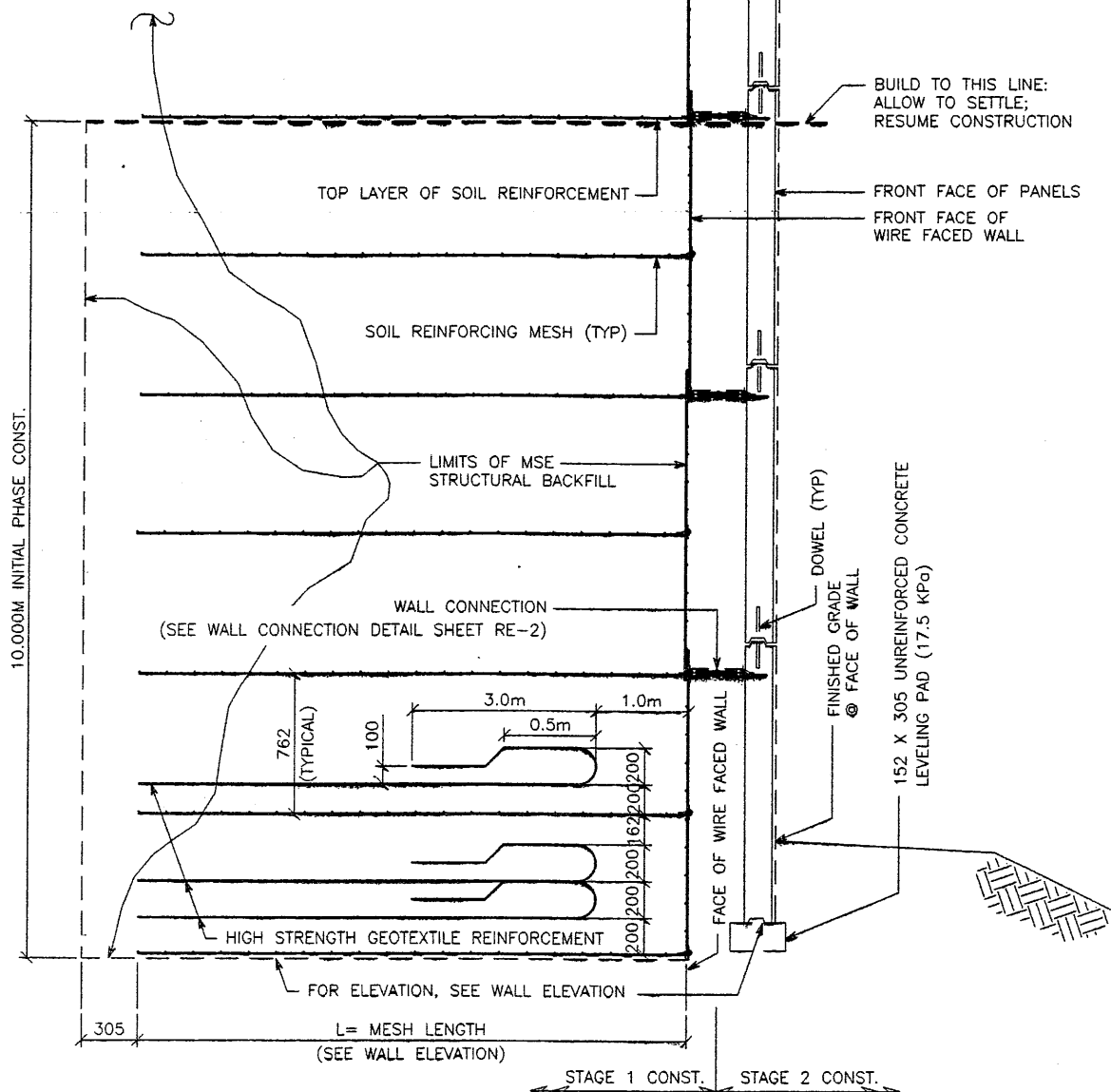

**TYPICAL CROSS SECTION
AT VERTICAL PHASE CONST.**
SCALE: 1:20 (FULL SIZE)
SCALE: 1:40 (HALF SIZE)

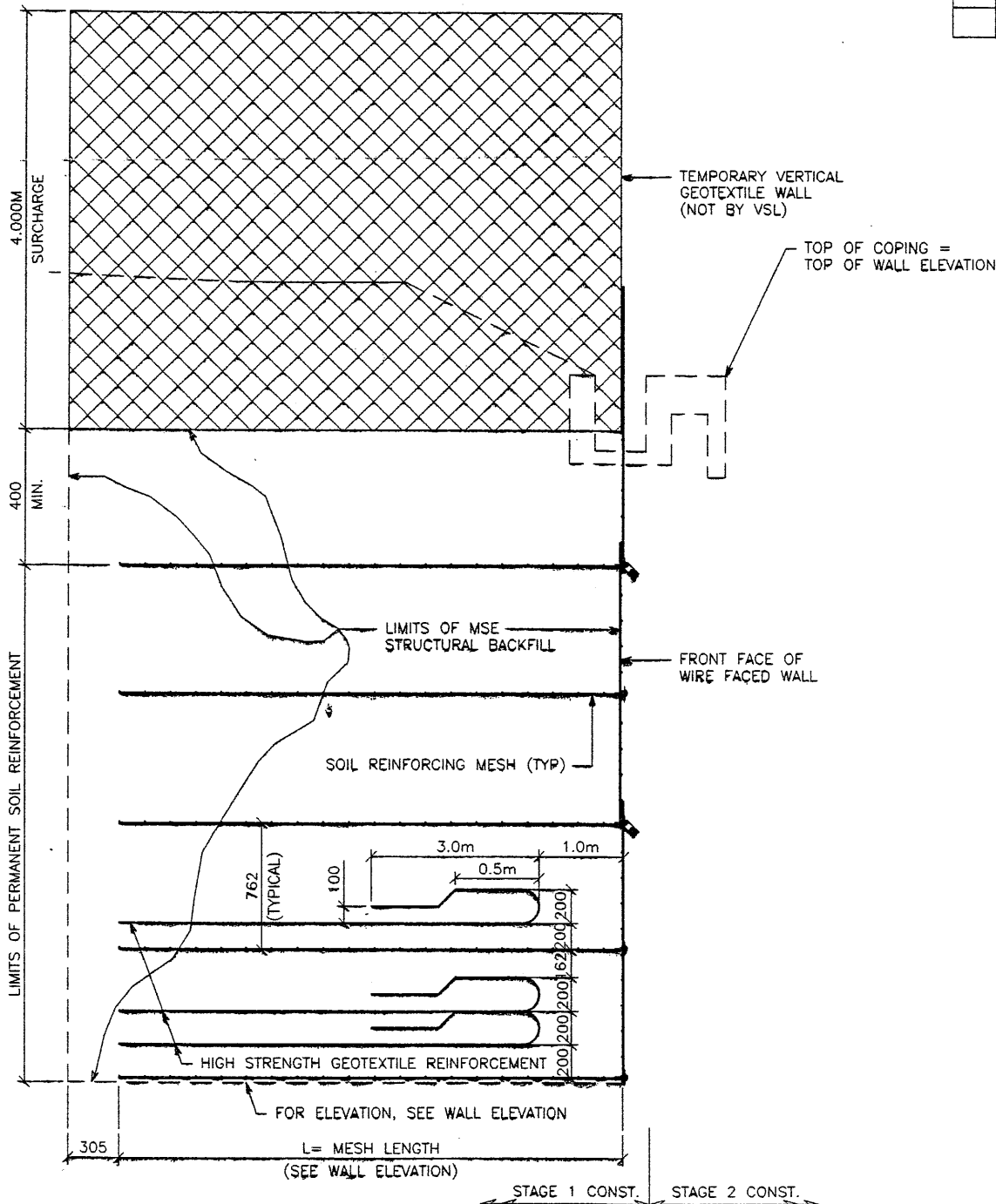

**TYPICAL CROSS SECTION
AT FINAL PHASE OF WIRE FACE WALL**
SCALE: 1:20 (FULL SIZE)
SCALE: 1:40 (HALF SIZE)

APPROVED FOR CONSTRUCTION		
NO.	DATE	DESCRIPTION
1	12-02-97	RELEASE FOR 1ST STAGE CONST. ONLY <i>ov</i>

WASATCH CONSTRUCTORS
DEC 10 1997
RELEASED FOR CONSTRUCTION

DES.	DRN.	CHK.	NO.	DATE	REVISION
09-22-97	MM				
09-22-97	DDO				
09-22-97	MM				

VSL CORPORATION
2800 Pineda Plaza, Suite 200
Houston, TX 77057
Phone: (713) 781-6272
Fax: (713) 781-6889

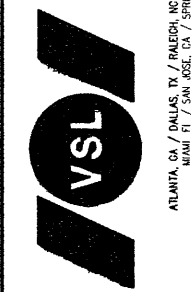

VSL Corporation (VSL) is not responsible for the design, construction, or maintenance of any structure. The use of any information in this document is at the user's discretion. VSL is not liable for any damage or injury resulting from the use of this document. THE USER ASSUMES ALL LIABILITY FOR THE DESIGN, CONSTRUCTION, AND MAINTENANCE OF ANY STRUCTURE.

RETAINED EARTH™ WALLS
WIRE FACED WALL "R-350-11"
TYPICAL SECTIONS @ WIRE FACED WALL
UTAH I-15 INTERCHANGE
SALT LAKE COUNTY, UTAH
UTAH DEPARTMENT OF TRANSP.

SHT 8 OF 16
METRIC

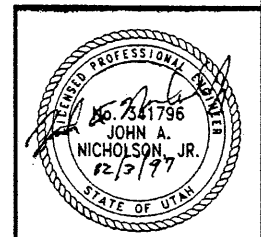

CERTIFIED FOR INTERNAL STABILITY OF RETAINED EARTH™ STRUCTURES ONLY. EXTERNAL STABILITY, INCLUDING BUT NOT LIMITED TO FOUNDATION AND SLOPE STABILITY, IS THE RESPONSIBILITY OF THE OWNER. DESIGN IS BASED ON THE ASSUMPTION THAT THE MATERIAL WITHIN THE RETAINED EARTH™ MASS, METHODS OF CONSTRUCTION, AND QUALITY OF PREFABRICATED MATERIALS CONFORM TO THE MANUFACTURER'S SPECIFICATION.

SCALE:	3.1R-350-11.8
JOB NO.:	239-0007
	RE-4

APPROVED FOR CONSTRUCTION		
NO.	DATE	DESCRIPTION
△	12-02-97	RELEASE FOR 1ST STAGE CONST. ONLY <i>dl</i>

COLUMN #'S	DEPTH, METERS
1-35	1.0M
36-41	1.5M
42-52	2.0M
53-61	2.5M
62-66	3.0M
67-93	3.5M
94-122	*

* 5.0M OR EXCAVATE TO ELEVATION 1286.500

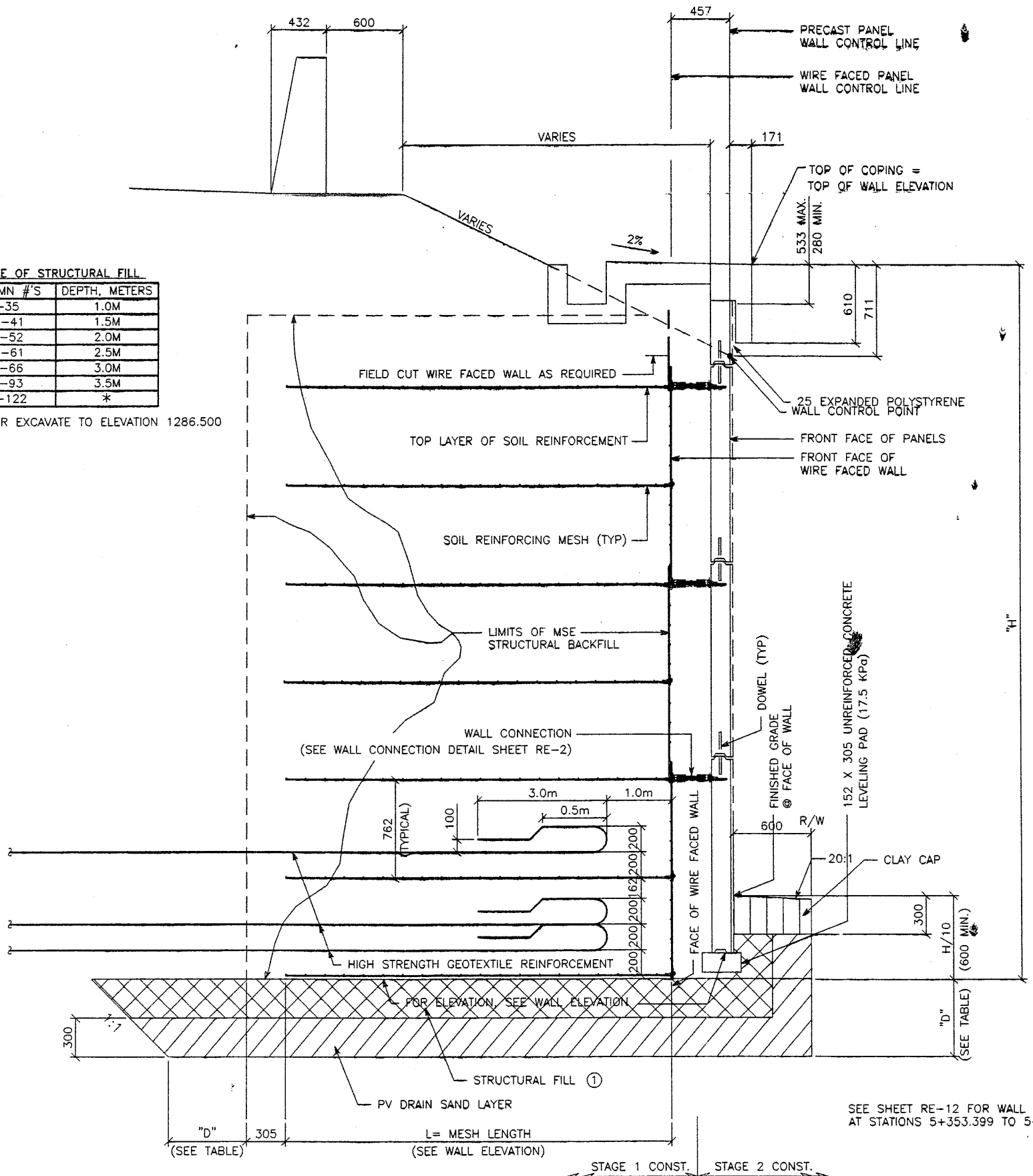

TYPICAL CROSS SECTION STA 5+042.000 TO 5+353.399
(SEE DWG. NO. 3.1R-350-11.4 FOR ADDITIONAL INFORMATION)

SCALE: 1:20 (FULL SIZE)
SCALE: 1:40 (HALF SIZE)

SEE SHEET RE-12 FOR WALL SECTIONS AT STATIONS 5+353.399 TO 5+369.951

WASATCH CONSTRUCTORS
DEC 10 1997
RELEASED FOR CONSTRUCTION

VSL CORPORATION
2840 Plaza Place, Suite 200
Raleigh, NC 27612
Telephone: (919) 781-6272
Fax: (919) 781-4989



USE: CONSULTING ENGINEER
I am a duly licensed professional engineer in the State of North Carolina. I am the author of the design and construction of the structure shown on this sheet. The use of this sheet for any other purpose without my written consent is prohibited. My license number is 12137.

RETAINED EARTH™ WALLS
WIRE FACED WALL "R-350-11"
TYPICAL CROSS SECTION
UTAH I-15 INTERCHANGE

SHT 9 OF 16
METRIC

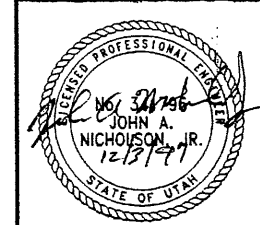

CERTIFIED FOR INTERNAL STABILITY OF RETAINED EARTH™ STRUCTURES ONLY. EXTERNAL STABILITY, INCLUDING BUT NOT LIMITED TO FOUNDATION AND SLOPE STABILITY, IS THE RESPONSIBILITY OF THE OWNER. DESIGN IS BASED ON THE ASSUMPTION THAT THE MATERIAL WITHIN THE RETAINED EARTH™ MASS, METHODS OF CONSTRUCTION, AND QUALITY OF PREFABRICATED MATERIALS CONFORM TO THE MANUFACTURER'S SPECIFICATION.

SCALE: 3.1R-350-1
JOB NO: 239-000
RE-5

H:\RE_EARTH\PROJECT\239-0007\13SERIES\13-111\SUBMITL-4\RE-5
FINAL PLOT 12-02-97

H:\RE_EARTH\PROJECT\239-0007\13SERIES\13-11\13-11.dwg

FINAL PL 12-02-97

APPROVED FOR CONSTRUCTION		
NO.	DATE	DESCRIPTION
1	12-02-97	RELEASE FOR 1ST STAGE CONST. ONLY

BEGIN WIRE FACED WALL R-350-11
 WIRE FACED WALL STA 5+042.000 =
 SB CD1 STA 3+409.272
 @ 25.502 RT

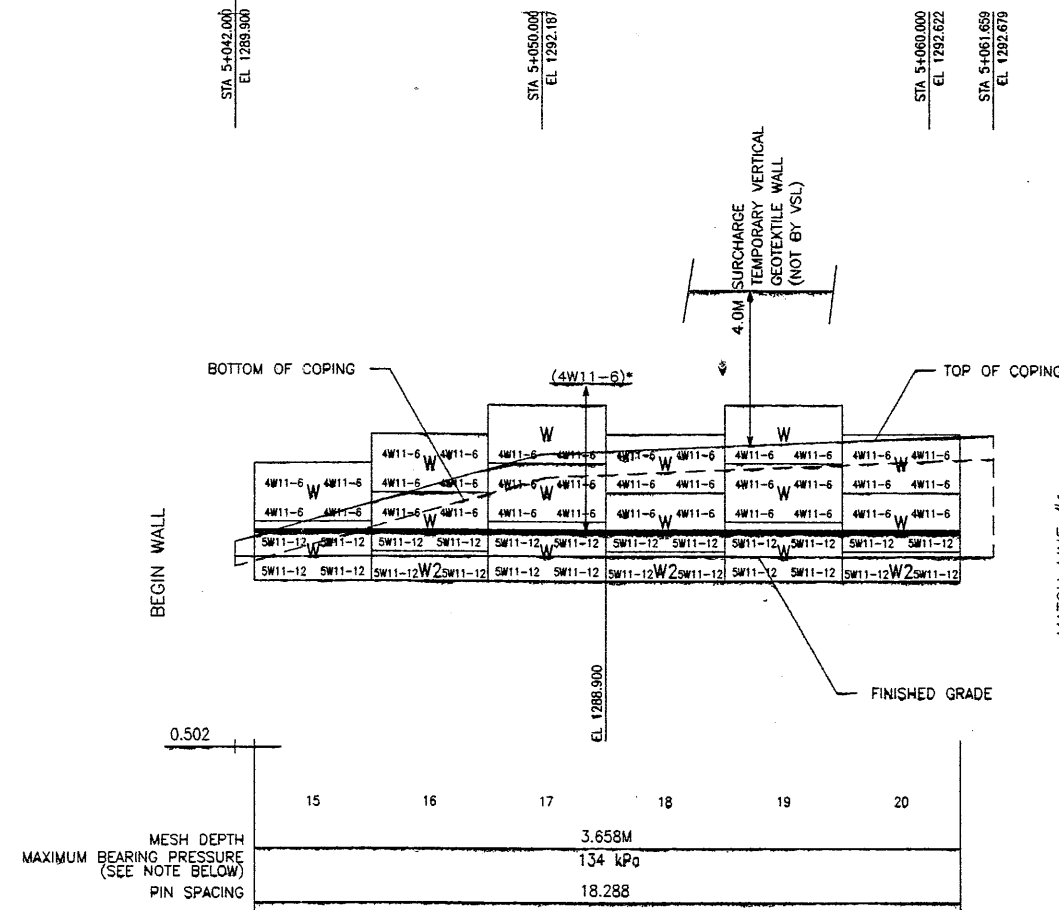

RETAINING WALL "R-350-11" - 1ST STAGE: WIRE FACED WALL
 (FRONT FACE SHOWN) SCALE 1:100 (FULL SIZE)
 (TOTAL SURFACE AREA OF FACING = 2,438.66 SM) SCALE 1:200 (HALF SIZE)

WASATCH CONSTRUCTORS
 DEC 10 1997
 RELEASED FOR CONSTRUCTION

VSL CORPORATION
 2840 Pinedale Place, Suite 200
 Tualatin, OR 97146
 Tel: (503) 761-4272
 Fax: (503) 761-4889



VSL Corporation (VSL) right in all design, specifications and calculations on the wall. The use of such information in any other project without the written consent of VSL is prohibited. VSL is not responsible for the material and/or any other use of this information.

* INDICATES SOIL REINFORCING TYPE MESH TO BE USED ON ADDITIONAL WIRE WALL FACING ADDED AFTER SETTLEMENT.

SHT 10 OF 16
 METRIC

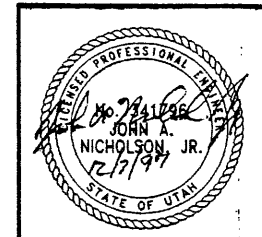

CERTIFIED FOR INTERNAL STABILITY OF RETAINED EARTH™ STRUCTURES ONLY. EXTERNAL STABILITY, INCLUDING BUT NOT LIMITED TO FOUNDATION AND SLOPE STABILITY, IS THE RESPONSIBILITY OF THE OWNER. DESIGN IS BASED ON THE ASSUMPTION THAT THE MATERIAL WITHIN THE RETAINED EARTH™ MASS, METHODS OF CONSTRUCTION, AND QUALITY OF PREFABRICATED MATERIALS CONFORM TO THE MANUFACTURER'S SPECIFICATION.

RETAINED EARTH™ WALLS	3.1R-350-11.10
WALL "R-350-11" - 1ST STAGE: WIRE FACED WALL	JOB NO:
UTAH I-15 INTERCHANGE	239-0007
SALT LAKE COUNTY, UTAH	RE-6

H:\RE_EARTH\PROJECT\239-0007\13SERIES\13-111-4\W13-111
FINAL PLL -02-97

APPROVED FOR CONSTRUCTION		
NO.	DATE	DESCRIPTION
△	12-02-97	RELEASE FOR 1ST STAGE CONST. ONLY <i>OV</i>

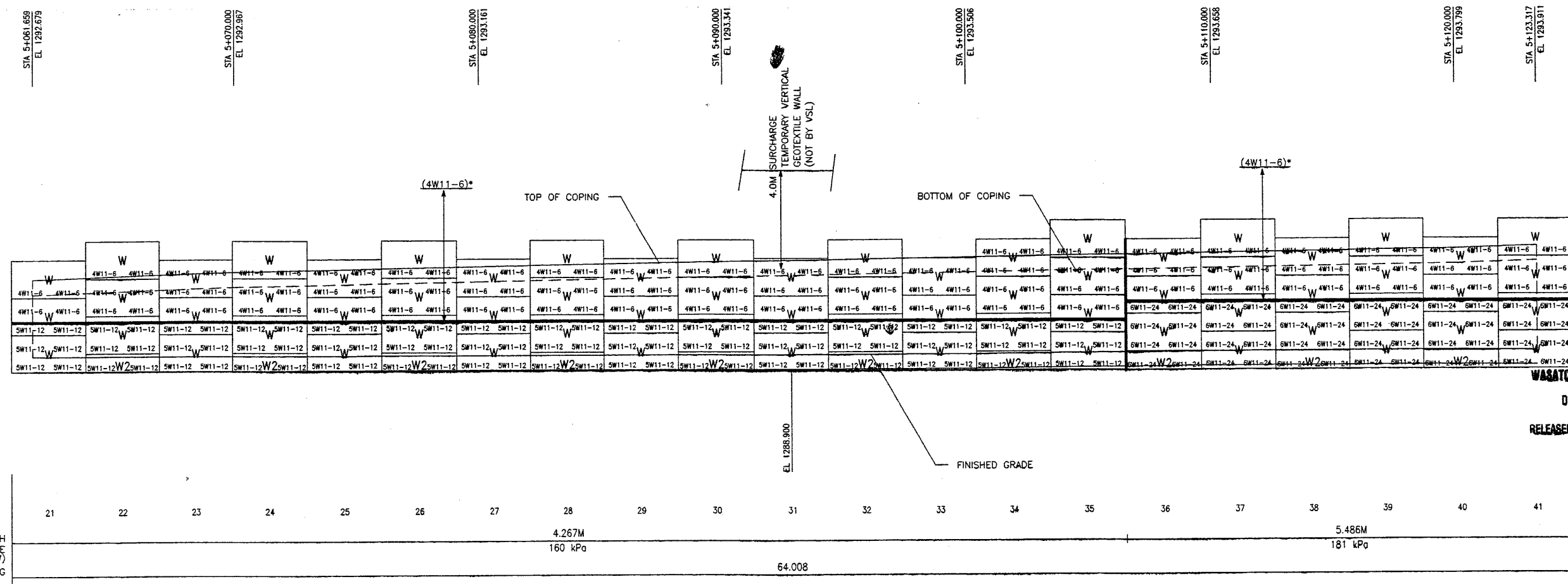

WASATCH CONSTRUCTORS
DEC 10 1997
RELEASED FOR CONSTRUCTION

RETAINING WALL "R-350-11" - 1ST STAGE: WIRE FACED WALL
(FRONT FACE SHOWN)
(TOTAL SURFACE AREA OF FACING = 2,438.66 SM)

SCALE 1:100 (FULL SIZE)
SCALE 1:200 (HALF SIZE)

* INDICATES SOIL REINFORCING TYPE MESH TO BE USED ON ADDITIONAL WIRE WALL FACING ADDED AFTER SETTLEMENT.

SHT 11 OF 16
METRIC

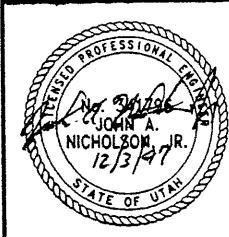

CERTIFIED FOR INTERNAL STABILITY OF RETAINED EARTH™ STRUCTURES ONLY. EXTERNAL STABILITY, INCLUDING BUT NOT LIMITED TO FOUNDATION AND SLOPE STABILITY, IS THE RESPONSIBILITY OF THE OWNER. DESIGN IS BASED ON THE ASSUMPTION THAT THE MATERIAL WITHIN THE RETAINED EARTH™ MASS, METHODS OF CONSTRUCTION, AND QUALITY OF PREFABRICATED MATERIALS CONFORM TO THE MANUFACTURER'S SPECIFICATION.

DES. 10-20-97 MM
DRN. 10-20-97 DDO
CHK. 10-20-97 MM

VSL CORPORATION
2940 Plaza Place, Suite 200
Raleigh, NC 27612
Telephone: (919) 781-6272
Fax: (919) 781-6889

ATLANTA, GA / DALLAS, TX / RALEIGH, NC (CORPORATE OFFICE)

RETAINED EARTH™
WALL "R-350-11" - 1ST STAGE: WIRE FACED WALL
UTAH I-15 INTERCHANGE
SALT LAKE COUNTY, UTAH
UTAH DEPARTMENT OF TRANSP.

SCALE:
3.1R-350-11.11
JOB NO:
239-0007
RE-7

H:\RE_EARTH\PROJECT\239-0007\13SERIES\13-111
 FINAL PL -02-97

APPROVED FOR CONSTRUCTION		
NO.	DATE	DESCRIPTION
1	12-02-97	RELEASE FOR 1ST STAGE CONST. ONLY <i>OK</i>

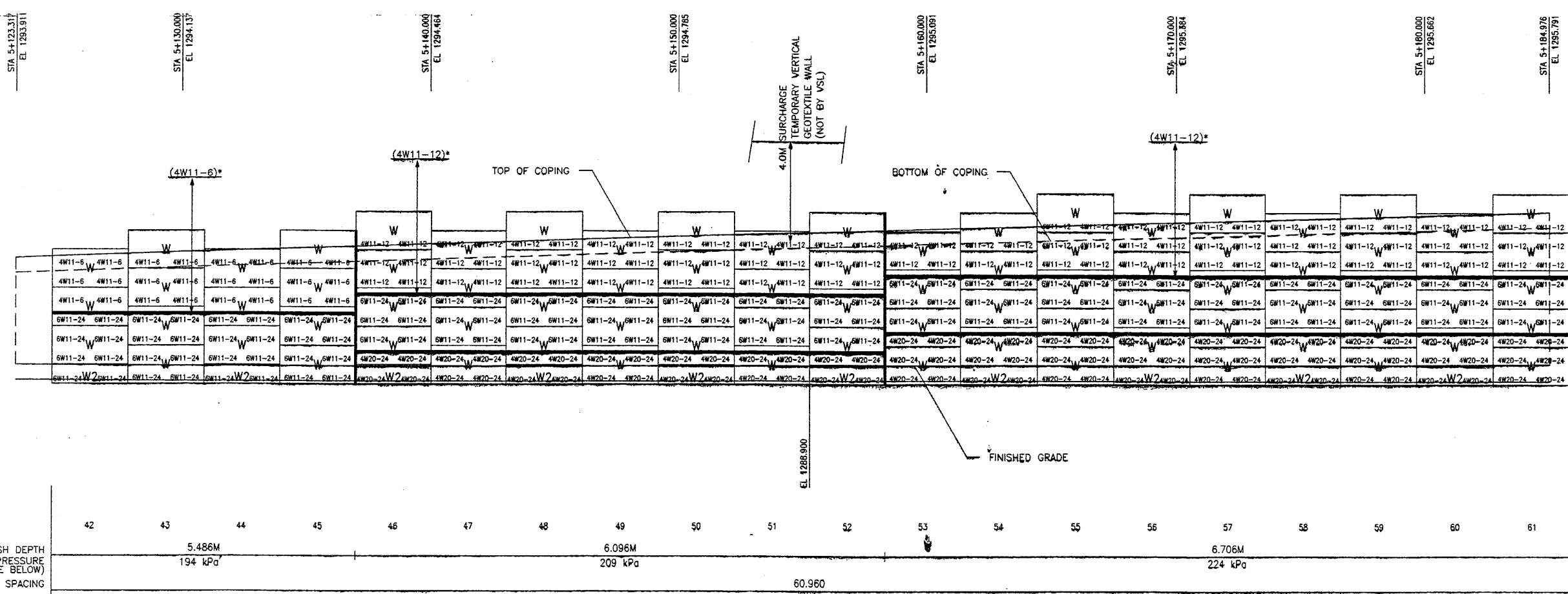

RETAINING WALL "R-350-11" - 1ST STAGE: WIRE FACED WALL
 (FRONT FACE SHOWN)
 (TOTAL SURFACE AREA OF FACING = 2,438.66 SM)
 SCALE 1:100 (FULL SIZE)
 SCALE 1:200 (HALF SIZE)

* INDICATES SOIL REINFORCING TYPE MESH TO BE USED ON ADDITIONAL WIRE WALL FACING ADDED AFTER SETTLEMENT.

WASATCH CONSTRUCTORS
 DEC 10 1997
 RELEASED FOR CONSTRUCTION

SHT 12 OF 16
 METRIC

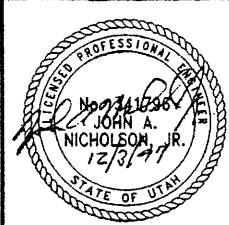

CERTIFIED FOR INTERNAL STABILITY OF RETAINED EARTH™ STRUCTURES ONLY. EXTERNAL STABILITY, INCLUDING BUT NOT LIMITED TO FOUNDATION AND SLOPE STABILITY, IS THE RESPONSIBILITY OF THE OWNER. DESIGN IS BASED ON THE ASSUMPTION THAT THE MATERIAL WITHIN THE RETAINED EARTH™ MASS, METHODS OF CONSTRUCTION, AND QUALITY OF PREFABRICATED MATERIALS CONFORM TO THE MANUFACTURER'S SPECIFICATION.

DES.	10-20-97	MM
DRN.	10-20-97	DDO
CHK.	10-20-97	MM
RETAINED EARTH™		

VSL CORPORATION
 9840 Pine Plaza, Suite 200
 Edinburg, TX 78742
 Telephone: (919) 781-6272
 Fax: (919) 781-6889

UTAH 1-15 INTERCHANGE
 SALT LAKE COUNTY, UTAH
 IUTAH DEPARTMENT OF TRANSPORTATION

SCALE:	3.1R-350-11.12
JOB NO.:	239-0007
RE-8	

H:\RE_EARTH\PROJECT\239-0007\13SERIES\13-111\13-111-4\W13-111
FINAL P.L.C. 12-02-97

APPROVED FOR CONSTRUCTION		
NO.	DATE	DESCRIPTION
1	12-02-97	RELEASE FOR 1ST STAGE CONST. ONLY <i>OV</i>

DES.	MM
10-20-97	MM
DRN.	DDO
10-20-97	DDO
CHK.	MM
10-20-97	MM

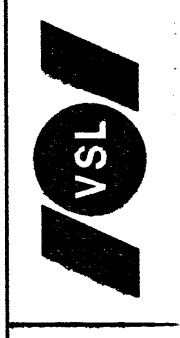

VSL CORPORATION
2840 Plaza Place, Suite 200
Raleigh, NC 27612
Telephone: (919) 781-6272
Fax: (919) 781-4869

RETAINED EARTH™ WALLS
WALL "R-350-11" - 1ST STAGE: WIRE FACED WALL
UTAH I-15 INTERCHANGE
SALT LAKE COUNTY, UTAH

SCALE:	3.1R-350-11.13
JOB NO:	239-0007
	RE-9

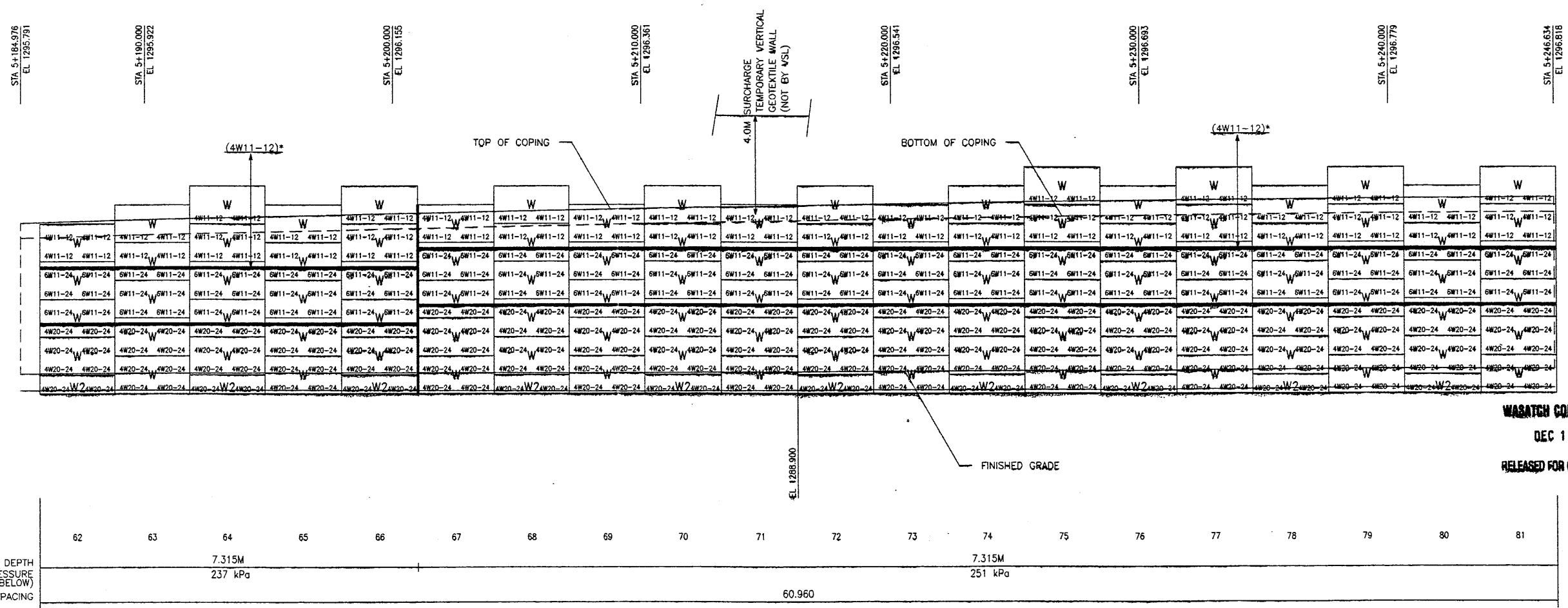

RETAINING WALL "R-350-11" - 1ST STAGE: WIRE FACED WALL
(FRONT FACE SHOWN) SCALE 1:100 (FULL SIZE)
(TOTAL SURFACE AREA OF FACING = 2,438.66 SM) SCALE 1:200 (HALF SIZE)

WASATCH CONSTRUCTORS
DEC 10 1997
RELEASED FOR CONSTRUCTION

SHT 13 OF 14
METRIC

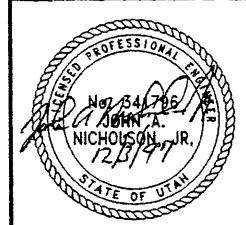

CERTIFIED FOR INTERNAL STABILITY OF RETAINED EARTH™ STRUCTURES ONLY. EXTERNAL STABILITY, INCLUDING BUT NOT LIMITED TO FOUNDATION AND SLOPE STABILITY, IS THE RESPONSIBILITY OF THE OWNER. DESIGN IS BASED ON THE ASSUMPTION THAT THE MATERIAL WITHIN THE RETAINED EARTH™ MASS, METHODS OF CONSTRUCTION, AND QUALITY OF PREFABRICATED MATERIALS CONFORM TO THE MANUFACTURER'S SPECIFICATION.

* INDICATES SOIL REINFORCING TYPE MESH TO BE USED ON ADDITIONAL WIRE WALL FACING ADDED AFTER SETTLEMENT.

4W13-111

H:\RE_EARTH\PROJECT\239-0007\1SERIES\13-11

-02-97

FINAL PI

APPROVED FOR CONSTRUCTION		
NO.	DATE	DESCRIPTION
1	10-02-97	RELEASE FOR 1ST STAGE CONST. ONLY

DES.	MM	DRN.	DDO	CHK.	MM	NO.	DATE	REVISION

VSL CORPORATION
 2840 Riva Plaza, Suite 200
 Raleigh, NC 27612
 Telephone: (919) 781-6272
 Fax: (919) 781-4868

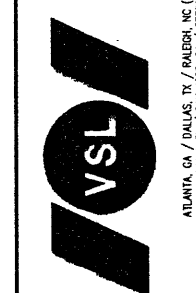

ATLANTA, GA / DALLAS, TX / RALEIGH, NC (CORPORATE OFFICE)
 MIAMI, FL / SAN JOSE, CA / SPRINGFIELD, VA

RETAINED EARTH™ WALLS
 WALL "R-350-11" - 1ST STAGE: WIRE FACED WALL
 UTAH I-15 INTERCHANGE
 SALT LAKE COUNTY, UTAH
 UTAH DEPARTMENT OF TRANSP.

WASATCH CONSTRUCTORS
 DEC 10 1997
 RELEASED FOR CONSTRUCTION

SHT 14 OF 16
 METRIC

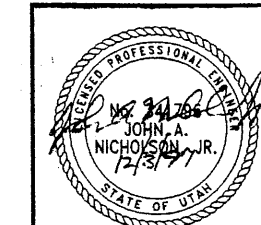

SCALE:
 3.1R-350-11.14
 JOB NO:
 239-0007
 RE-10

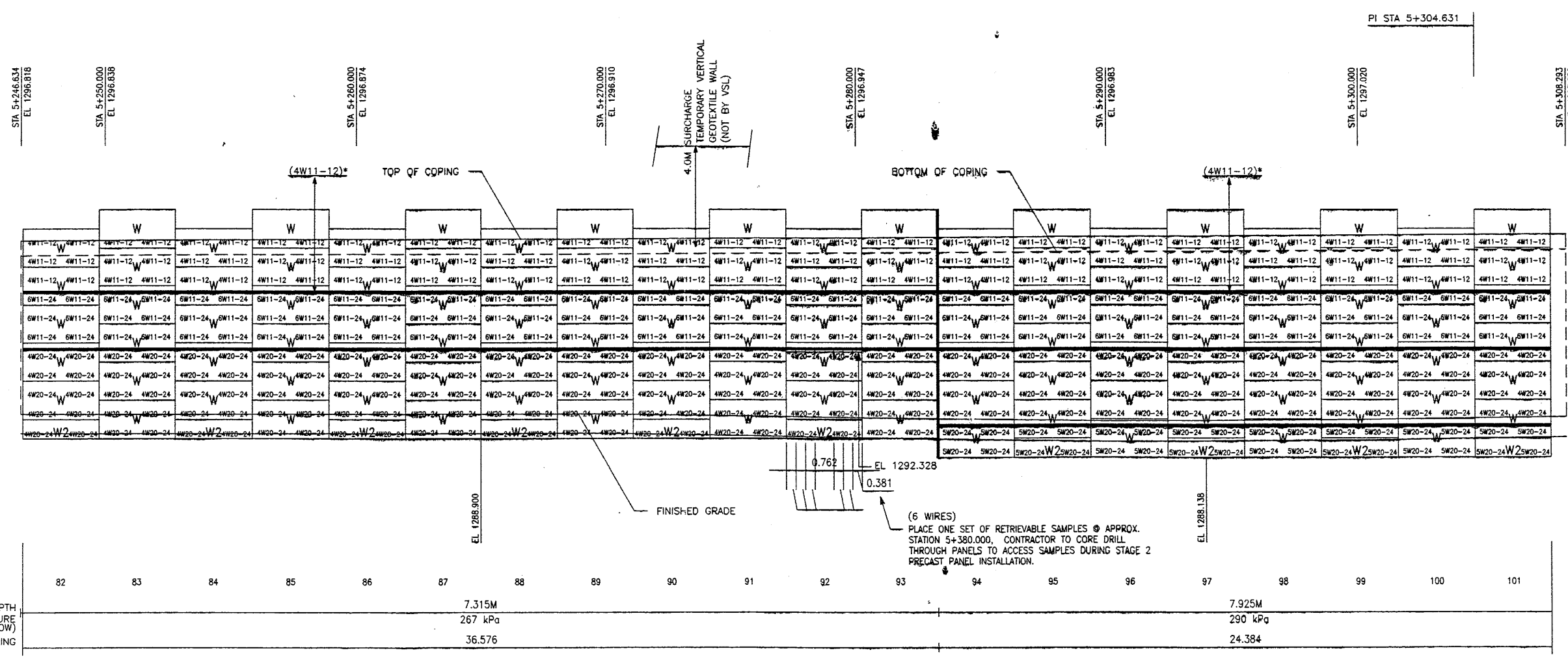

RETAINING WALL "R-350-11" - 1ST STAGE: WIRE FACED WALL
 (FRONT FACE SHOWN) SCALE 1:100 (FULL SIZE)
 (TOTAL SURFACE AREA OF FACING = 2,438.66 SM) SCALE 1:200 (HALF SIZE)

* INDICATES SOIL REINFORCING TYPE MESH TO BE USED ON ADDITIONAL WIRE WALL FACING ADDED AFTER SETTLEMENT.

CERTIFIED FOR INTERNAL STABILITY OF RETAINED EARTH™ STRUCTURES ONLY. EXTERNAL STABILITY, INCLUDING BUT NOT LIMITED TO FOUNDATION AND SLOPE STABILITY, IS THE RESPONSIBILITY OF THE OWNER. DESIGN IS BASED ON THE ASSUMPTION THAT THE MATERIAL WITHIN THE RETAINED EARTH™ MASS, METHODS OF CONSTRUCTION, AND QUALITY OF PREFABRICATED MATERIALS CONFORM TO THE MANUFACTURER'S SPECIFICATION.

APPROVED FOR CONSTRUCTION		
NO.	DATE	DESCRIPTION
1	12-02-97	RELEASE FOR 1ST STAGE CONST. ONLY

NOTE: PILES TO BE LOCATED PRIOR TO ERECTION OF WIRE FACED WALL. SOIL REINFORCEMENT TO BE FIELD ADJUSTED TO AVOID PILES.

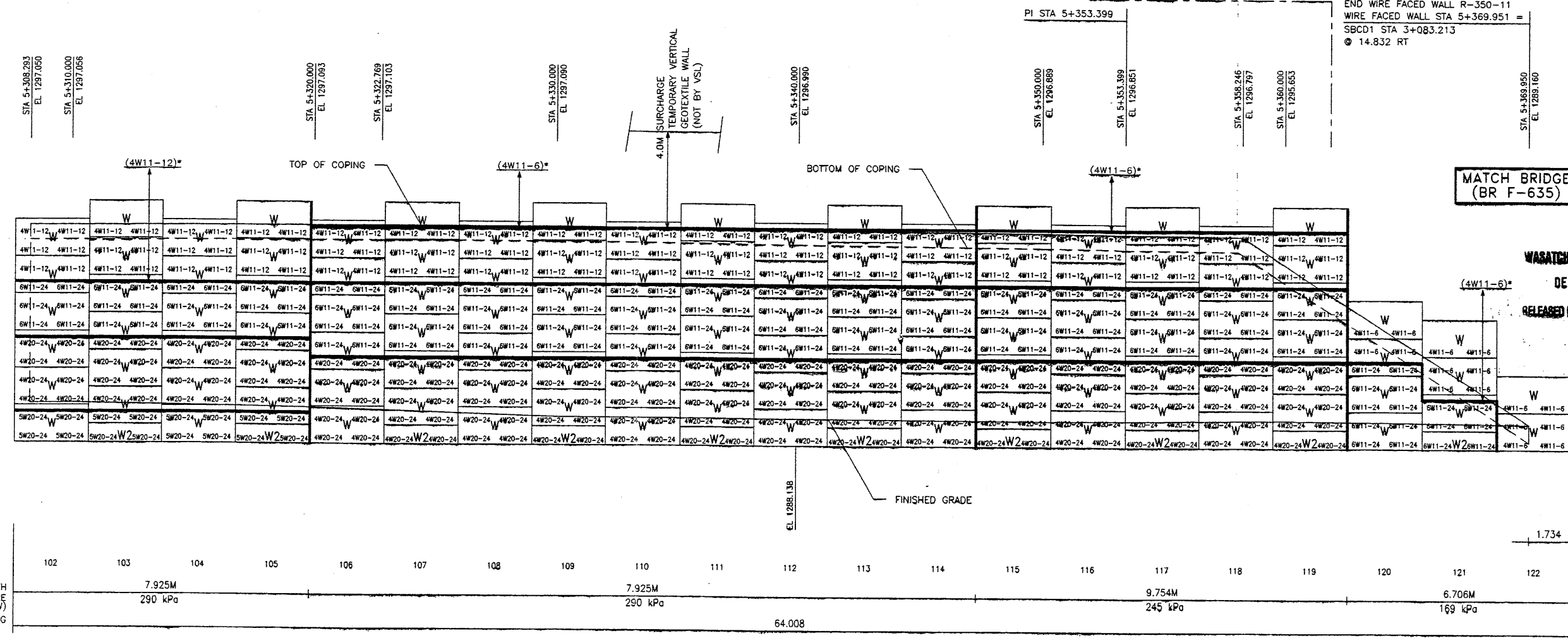
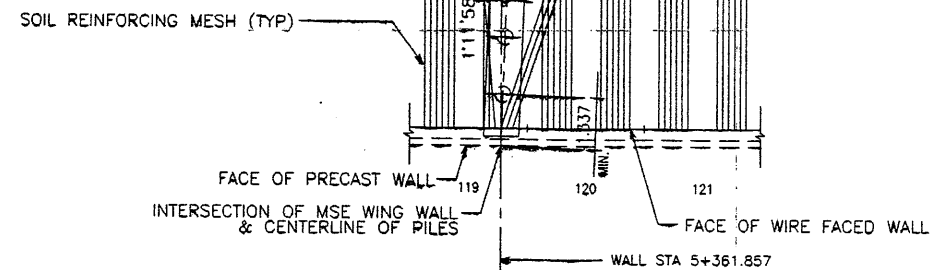

MATCH BRIDGE (BR F-635)

WASATCH CONSTRUCTORS
DEC 10 1997
RELEASED FOR CONSTRUCTION

RETAINING WALL "R-350-11" - 1ST STAGE: WIRE FACED WALL

(FRONT FACE SHOWN)
(TOTAL SURFACE AREA OF FACING = 2,438.66 SM)

SCALE 1:100 (FULL SIZE)
SCALE 1:200 (HALF SIZE)

SHT 15 OF 16
METRIC

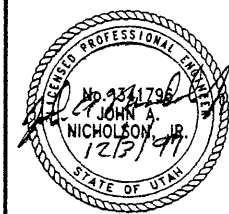

CERTIFIED FOR INTERNAL STABILITY OF RETAINED EARTH™ STRUCTURES ONLY. EXTERNAL STABILITY, INCLUDING BUT NOT LIMITED TO FOUNDATION AND SLOPE STABILITY, IS THE RESPONSIBILITY OF THE OWNER. DESIGN IS BASED ON THE ASSUMPTION THAT THE MATERIAL WITHIN THE RETAINED EARTH™ MASS, METHODS OF CONSTRUCTION, AND QUALITY OF PREFABRICATED MATERIALS CONFORM TO THE MANUFACTURER'S SPECIFICATION.

DES.	10-20-97	MM	NO.	DATE
DRN.	10-20-97	DDO	NO.	DATE
CHK.	10-20-97	MM	NO.	DATE

BY: CHK

REVISION

RETAINED EARTH™

VSL CORPORATION
2840 Plaza Place, Suite 200
Raleigh, NC 27612
Telephone: (919) 781-6272
Fax: (919) 781-4669

ATLANTA, GA / DALLAS, TX / FREDERICK, MD (CORPORATE OFFICE)
MIAMI, FL / SAN JOSE, CA / SPRINGFIELD, VA

VSL

UTAH 1-15 INTERCHANGE
SALT LAKE COUNTY, UTAH
UTAH DEPARTMENT OF TRANSP.

RETAINED EARTH™ WALLS
WALL "R-350-11" - 1ST STAGE: WIRE FACED WALL

SCALE:
3.1R-350-11.15
JOB NO:
239-0007
RE-11

H:\RE_EARTH\PROJECT\239-0007\13SERIES\13-111\SUBMITL-4\RE-12

FINAL PLOT 12-02-97

TABLE OF STRUCTURAL FILL

COLUMN #'S	DEPTH, METERS
1-35	1.0M
36-41	1.5M
42-52	2.0M
53-61	2.5M
62-66	3.0M
67-93	3.5M
94-122	*

* 5.0M OR EXCAVATE TO ELEVATION 1286.500

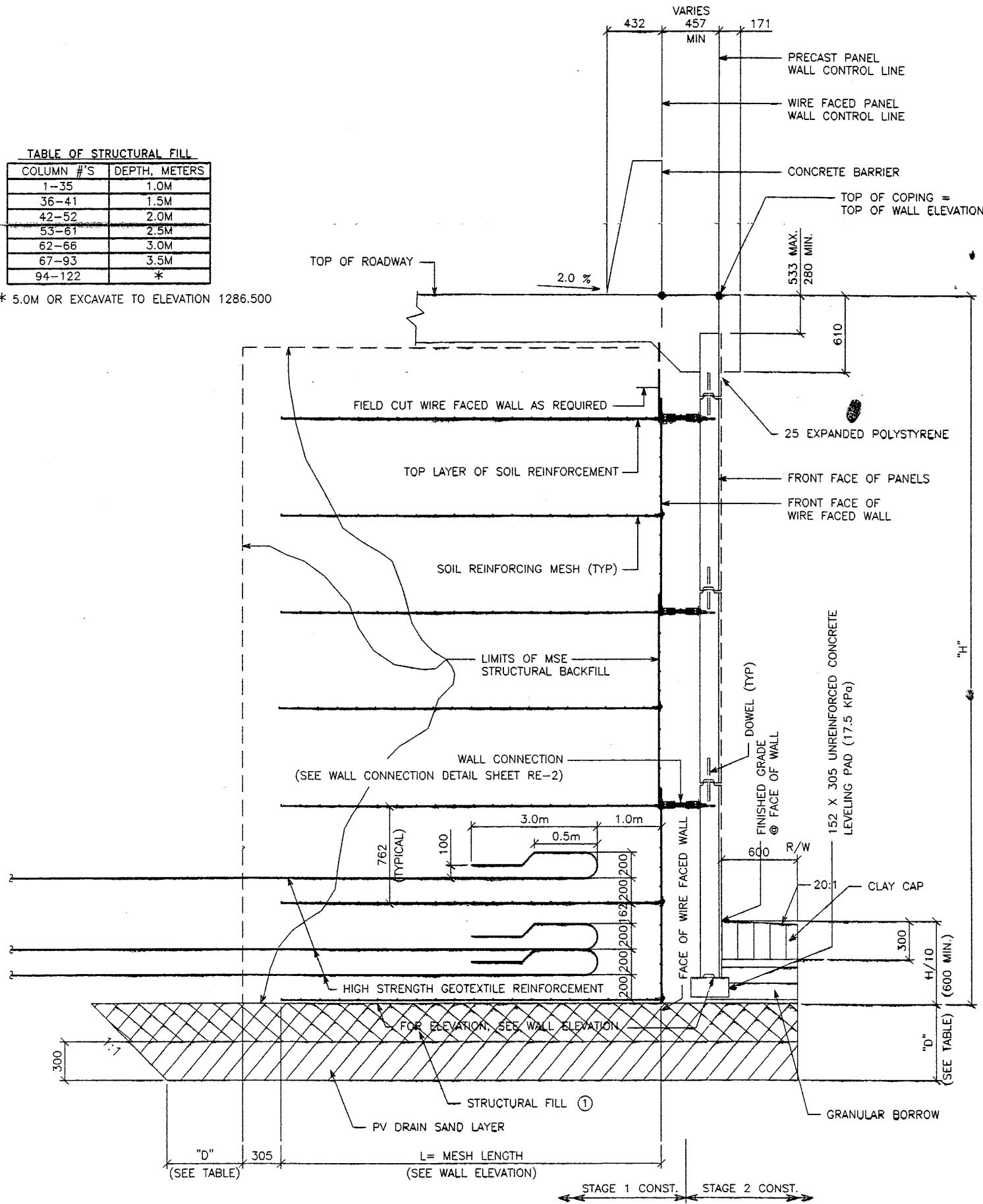

TYPICAL CROSS SECTION STA 5+353.399 TO 5+358.246

(SEE DWG. NO. 3.1R-350-11.4 FOR ADDITIONAL INFORMATION)

SCALE: 1:20 (FULL SIZE)

SCALE: 1:40 (HALF SIZE)

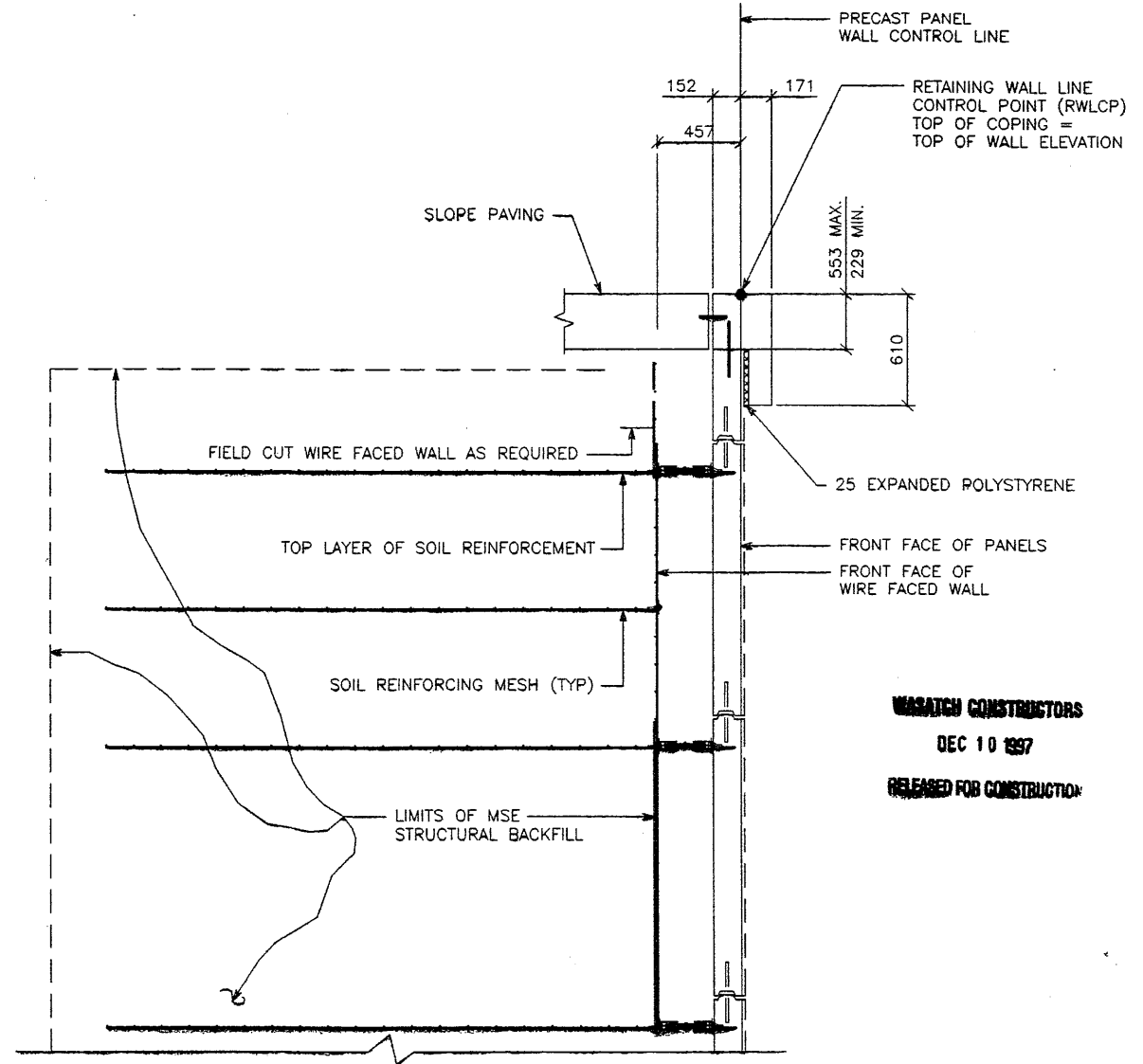

TYPICAL CROSS SECTION - STA 5+358.246 TO 5+369.951

(SEE DWG. NO. 3.1R-350-11.4 FOR ADDITIONAL INFORMATION)

SCALE: 1:20 (FULL SIZE)

SCALE: 1:40 (HALF SIZE)

SHT 16 OF 16
METRIC

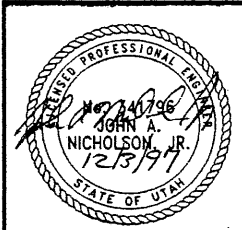

CERTIFIED FOR INTERNAL STABILITY OF RETAINED EARTH™ STRUCTURES ONLY. EXTERNAL STABILITY, INCLUDING BUT NOT LIMITED TO FOUNDATION AND SLOPE STABILITY, IS THE RESPONSIBILITY OF THE OWNER. DESIGN IS BASED ON THE ASSUMPTION THAT THE MATERIAL WITHIN THE RETAINED EARTH™ MASS, METHODS OF CONSTRUCTION, AND QUALITY OF PREFABRICATED MATERIALS CONFORM TO THE MANUFACTURER'S SPECIFICATION.

APPROVED FOR CONSTRUCTION

NO.	DATE	DESCRIPTION
△	12-02-97	RELEASE FOR 1ST STAGE CONST. ONLY <i>OK</i>

DES.	MM	DDO	MM
10-20-97			
DRN.	10-20-97		
CHK.	10-20-97		

VSL CORPORATION
2800 Plaza Place, Suite 200
Baltimore, MD 21287
Tel: (410) 781-6272
Fax: (410) 781-4869



WARREN CONSTRUCTORS
DEC 10 1997
RELEASED FOR CONSTRUCTION

RETAINED EARTH™ WALLS
WIRE FACED WALL "R-350-11"
TYPICAL CROSS SECTION
UTAH I-15 INTERCHANGE
SALT LAKE COUNTY, UTAH

SCALE: 3.1R-350-11.1

JOB NO:	239-0007

RE-12

BEGIN WALL R-350-11
WALL STA 5+042.000
SB CD1 STA 3+409.252
@ 28.273 LT
NOMINAL PANEL FACE (RWLOL)

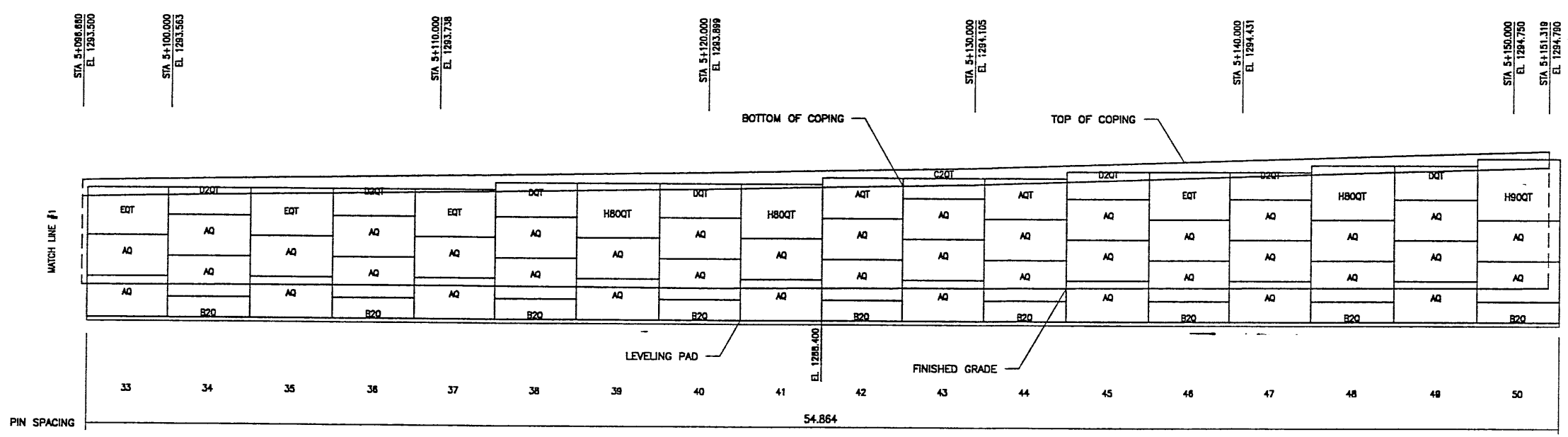
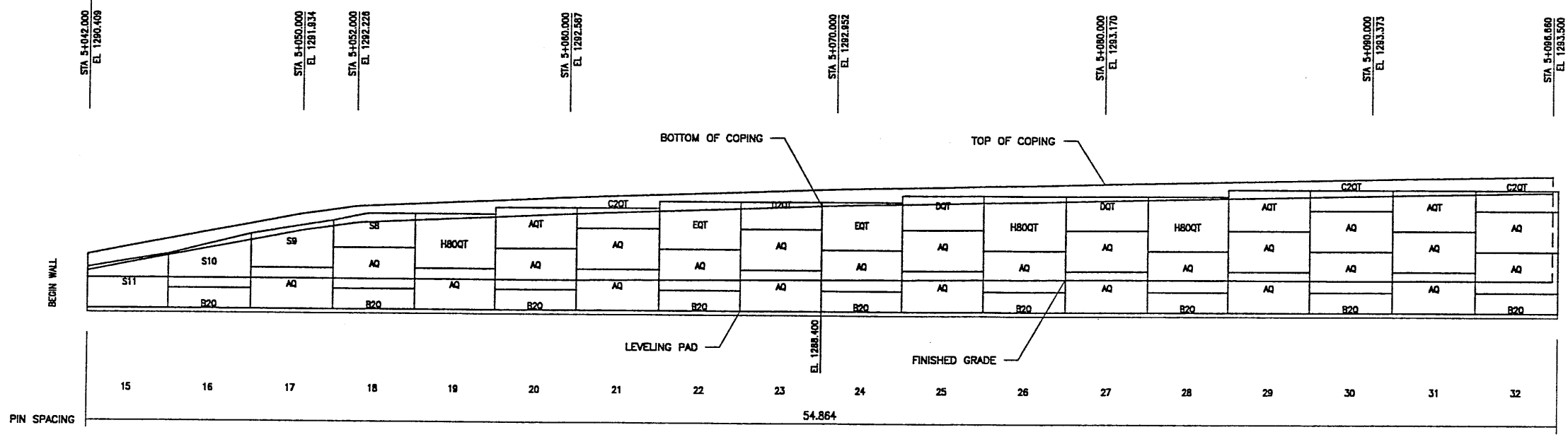

ELEVATION PRECAST WALL R-350-11
(FRONT FACE SHOWN)
(TOTAL SURFACE AREA OF PANELS = 2140.80 SM)
SCALE 1:100 (FULL SIZE)
SCALE 1:200 (HALF SIZE)

METRIC

CERTIFIED FOR INTERNAL STABILITY OF RETAINED EARTH™ STRUCTURES ONLY. EXTERNAL STABILITY, INCLUDING BUT NOT LIMITED TO FOUNDATION AND SLOPE STABILITY, IS THE RESPONSIBILITY OF THE OWNER. DESIGN IS BASED ON THE ASSUMPTION THAT THE MATERIAL WITHIN THE RETAINED EARTH™ MASS, METHODS OF CONSTRUCTION, AND QUALITY OF PREFABRICATED MATERIALS CONFORM TO THE MANUFACTURER'S SPECIFICATION.

APPROVED FOR CONSTRUCTION		
NO.	DATE	DESCRIPTION
△	12-17-98	RELEASE FOR 2ND. STAGE CONSTRUCTION

NO.	DATE	REVISION

DES.	12-17-98	JN
DRN.	12-17-98	DSW
CHK.	12-17-98	JN

VSL CORPORATION
2810 Plano Place, Suite 200
Raleigh, NC 27612
Telephone: (919) 781-6272
Fax: (919) 781-4869

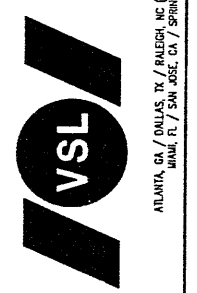

ATLANTA, GA / CHICAGO, IL / INGLEWOOD, CA (CORPORATE OFFICE)
JANAI, RI / SAN JOSE, CA / SPRINGFIELD, VA

MATCH LINE #2

MATCH LINE #1

WASATCH CONSTRUCTORS
JAN 22 1999
RELEASED FOR CONSTRUCTION

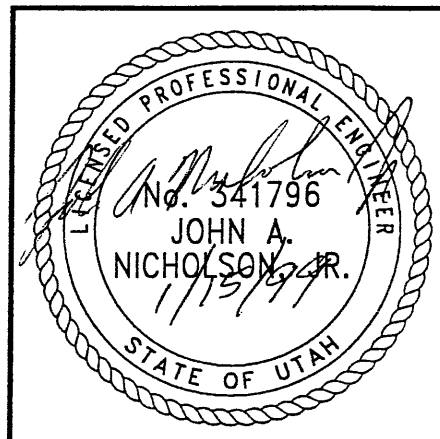

RETAINED EARTH™ WALLS
WALL "R-350-11" - 2ND STAGE: PRECAST WALL
UTAH 1-15 RECONSTRUCTION
SALT LAKE COUNTY, UTAH
UTAH DEPARTMENT OF TRANSP.

DWG. NO.	3.1R-350-11.17
JOB NO.	239-0007
SHT. NO.	RE-13

RFC After Final Approval

APPROVED FOR CONSTRUCTION		
NO.	DATE	DESCRIPTION
1	12-17-98	RELEASE FOR 2ND. STAGE CONSTRUCTION

DES.	DRN.	CHK.	RETAINED EARTH™	NO.	DATE	BY	CHK
12-17-98	JN	DSW					
12-17-98	JN						

VSL CORPORATION
 2840 Photo Place, Suite 200
 Raleigh, NC 27612
 Telephone: (919) 781-6272
 Fax: (919) 781-4869

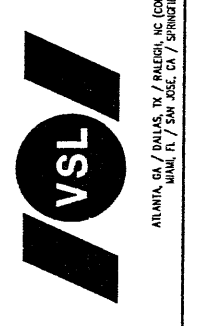

VSL Corporation ("VSL") owns a trade proprietary design and construction information not for sale. Such information is made available to the public for use in connection with the design and construction of retaining walls. VSL does not warrant the accuracy or completeness of the information provided, and VSL shall not be liable for any errors or omissions in the information provided.

RETAINED EARTH™ WALLS
 WALL "R-350-11" - 2ND STAGE: PRECAST WALL
 UTAH I-15 RECONSTRUCTION
 SALT LAKE COUNTY, UTAH
 UTAH DEPARTMENT OF TRANSP.

DWG. NO.	3.1R-350-11.18
JOB NO.	239-0007
SHT. NO.	RE-14

MATCH LINE #3

MATCH LINE #4

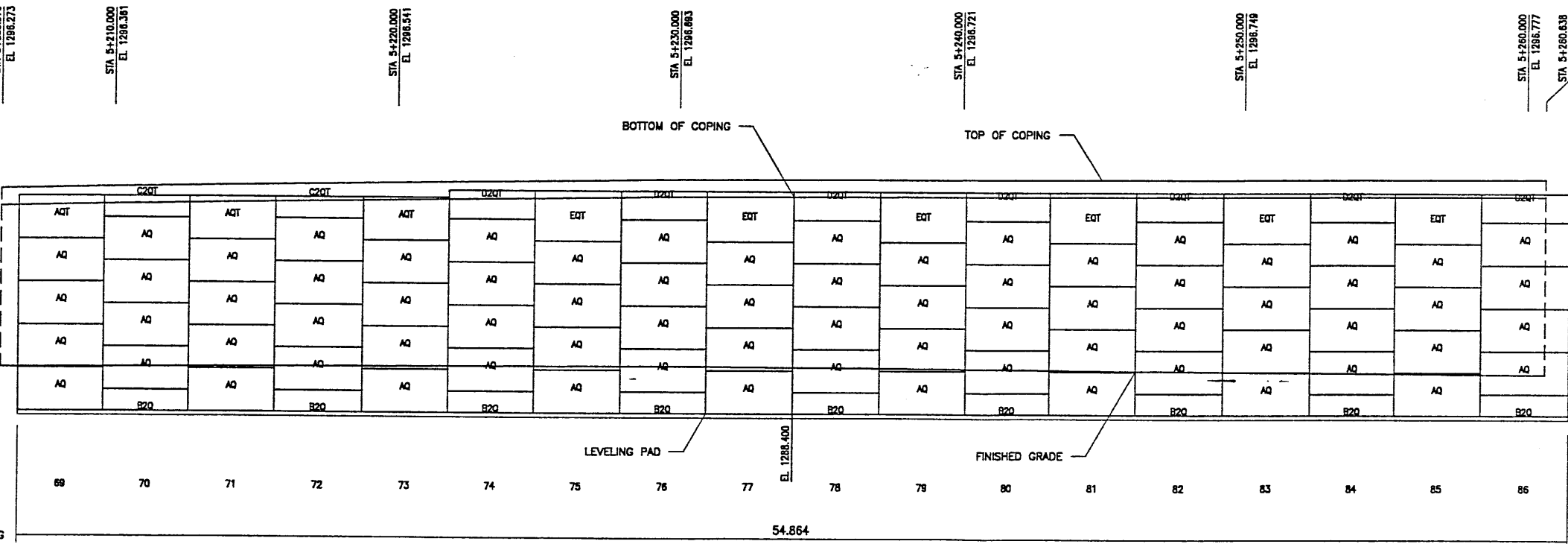
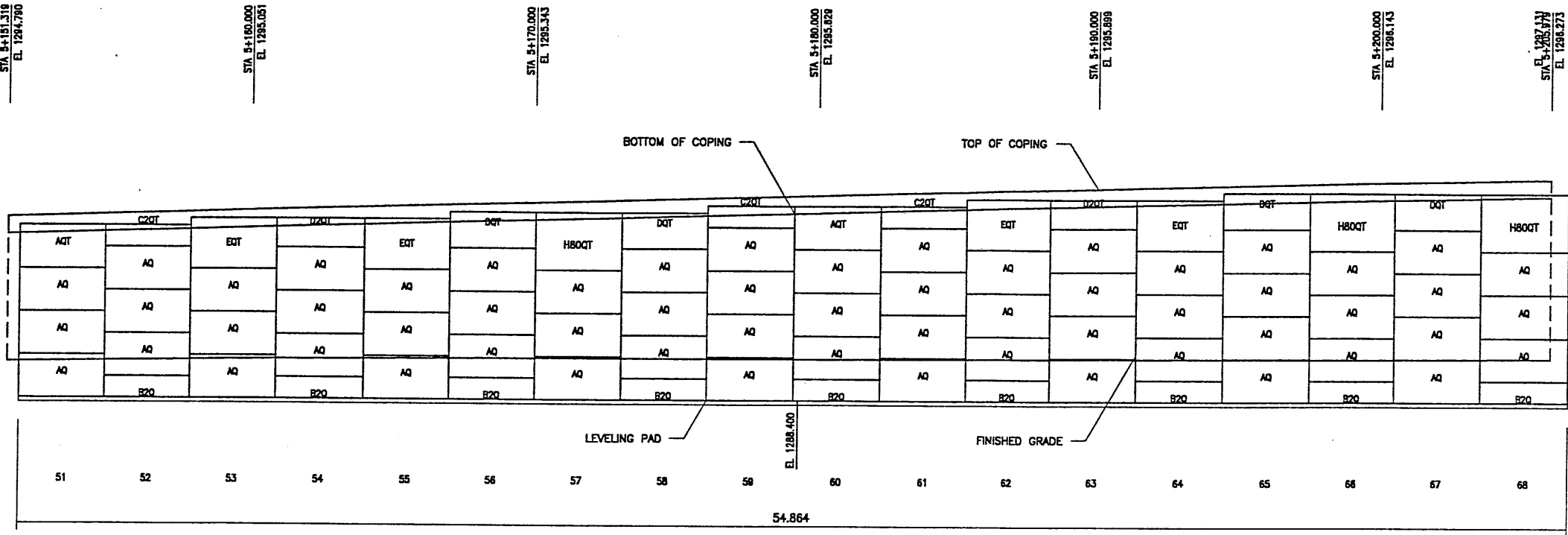

ELEVATION PRECAST WALL R-350-11

(FRONT FACE SHOWN) SCALE 1:100 (FULL SIZE)
 (TOTAL SURFACE AREA OF PANELS = 2140.90 SM) SCALE 1:200 (HALF SIZE)

METRIC

CERTIFIED FOR INTERNAL STABILITY OF RETAINED EARTH™ STRUCTURES ONLY. EXTERNAL STABILITY, INCLUDING BUT NOT LIMITED TO FOUNDATION AND SLOPE STABILITY, IS THE RESPONSIBILITY OF THE OWNER. DESIGN IS BASED ON THE ASSUMPTION THAT THE MATERIAL WITHIN THE RETAINED EARTH™ MASS, METHODS OF CONSTRUCTION, AND QUALITY OF PREFABRICATED MATERIALS CONFORM TO THE MANUFACTURER'S SPECIFICATION.

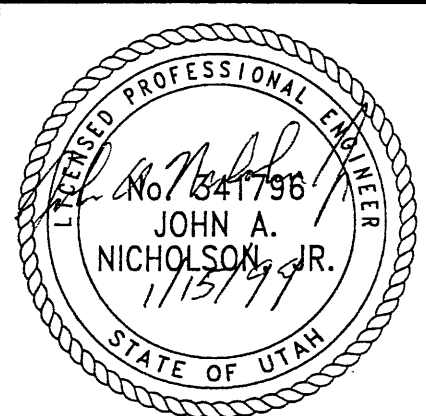

WASATCH CONSTRUCTORS
 JAN 22 1999
 RELEASED FOR CONSTRUCTION

RFC After Final Approval

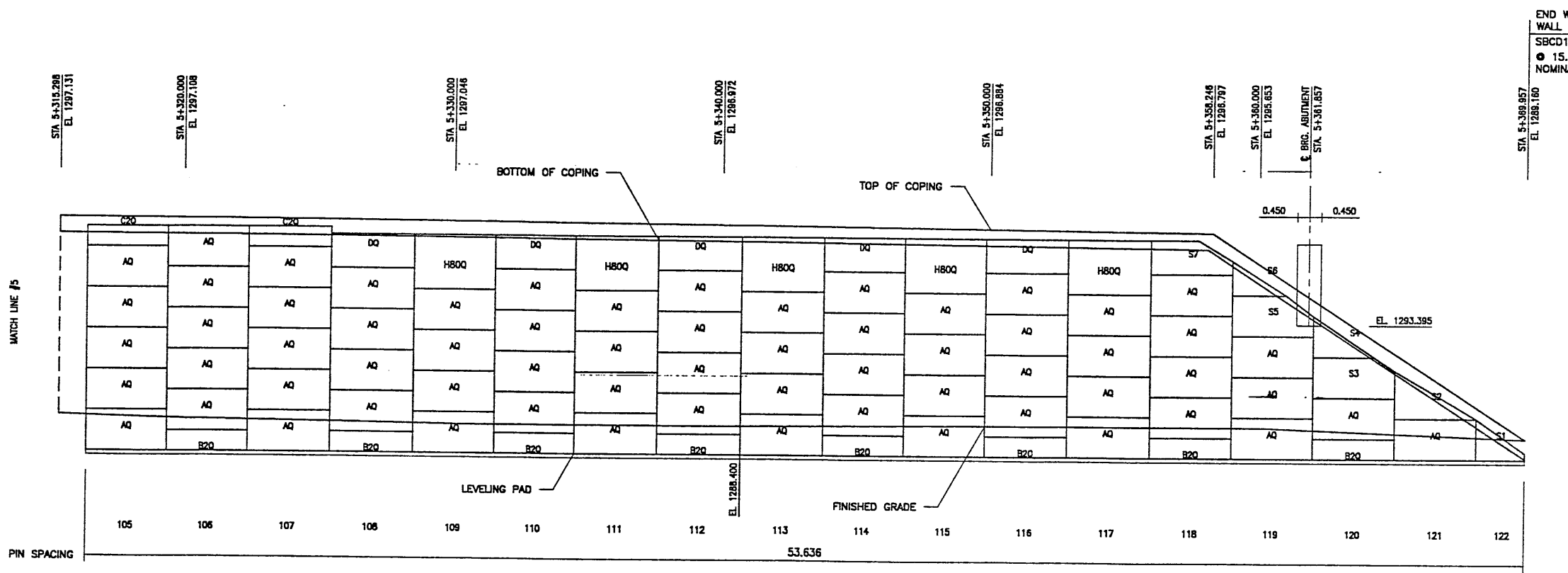
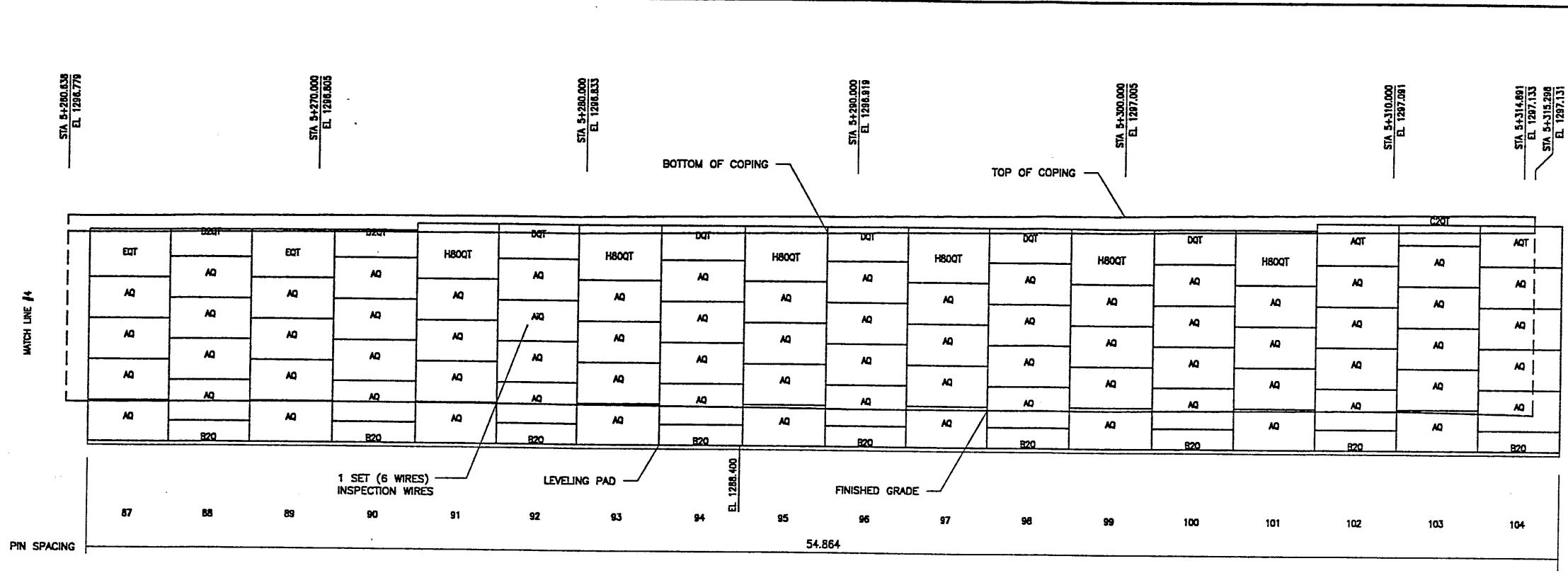

ELEVATION PRECAST WALL R-350-11
 (FRONT FACE SHOWN)
 (TOTAL SURFACE AREA OF PANELS = 2140.90 SM)
 SCALE 1:100 (FULL SIZE)
 SCALE 1:200 (HALF SIZE)

METRIC

CERTIFIED FOR INTERNAL STABILITY OF RETAINED EARTH™ STRUCTURES ONLY. EXTERNAL STABILITY, INCLUDING BUT NOT LIMITED TO FOUNDATION AND SLOPE STABILITY, IS THE RESPONSIBILITY OF THE OWNER. DESIGN IS BASED ON THE ASSUMPTION THAT THE MATERIAL WITHIN THE RETAINED EARTH™ MASS, METHODS OF CONSTRUCTION, AND QUALITY OF PREFABRICATED MATERIALS CONFORM TO THE MANUFACTURER'S SPECIFICATION.

APPROVED FOR CONSTRUCTION		
NO.	DATE	DESCRIPTION
△ 12-17-98		RELEASE FOR 2ND. STAGE CONSTRUCTION

DES.	DRN.	CHK.	RETAINED EARTH™	NO.	DATE	REVISION	BY	CHK
12-17-98	JUN							
12-17-98	DSW							
12-17-98	JUN							

VSL CORPORATION
 2840 Plaza Place, Suite 200
 Raleigh, NC 27612
 Telephone: (919) 781-6272
 Fax: (919) 781-6969

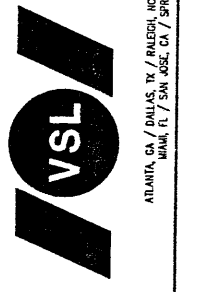

WASATCH CONSTRUCTION
 JAN 22 1999
 RELEASED FOR CONSTRUCTION

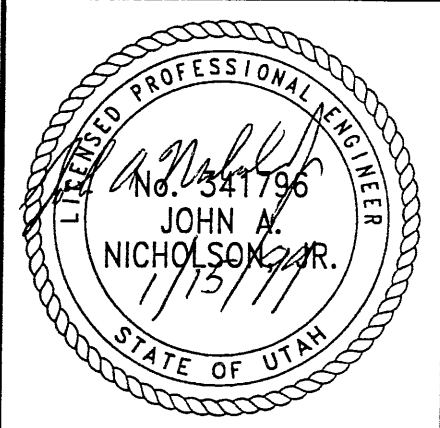

RETAINED EARTH™ WALLS
WALL "R-350-11" - 2ND STAGE: PRECAST WALL
UTAH I-15 RECONSTRUCTION
SALT LAKE COUNTY, UTAH
UTAH DEPARTMENT OF TRANSP.
DWG. NO.
3.1R-350-11.19
JOB NO:
239-0007
SHT. NO.
RE-15

RFC After Final Approval

Date: 16-MAY-1998 Time: 16:17 User: nmas.mcorrecg

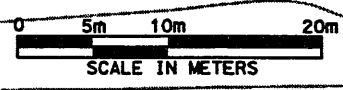
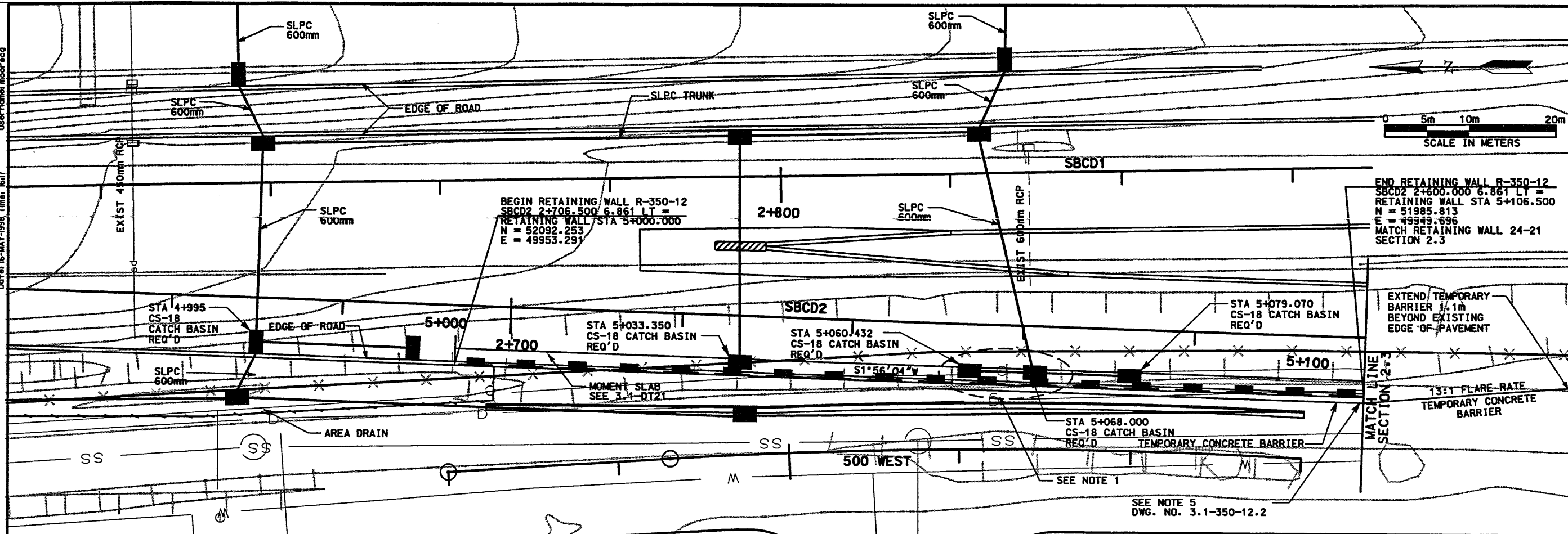

APPROVED FOR CONSTRUCTION		DESCRIPTION	
NO.	DATE		
1	10/06/97	ORIGINAL ISSUE	
2	3/25/98	98 EARLY G/D/P	
3	5/21/98	98 EARLY FINAL ROADWAY	

WBS NO.	3112800
CHECK	JAB 3/19/98
CHECK	JAB 3/17/98
CHECK	JAB 3/17/98

DESIGN DMC	7/29/97	CHECK	CJO 9/04/97
DRAWN	MVM 7/31/97	CHECK	CJO 9/04/97
QUANT.	JBW 3/17/98	CHECK	JAB 3/19/98

UTAH DEPARTMENT OF TRANSPORTATION	
MK CENTENNIAL SVERDRUP/DE LEUW	
APPROVAL	9/04/97 Bret A. Reynolds DATE PROJECT DESIGN ENGINEER
APPROVED	8/04/97 Raiddle L. Ross DATE PROJECT MANAGER
I-15 CORRIDOR RECONSTRUCTION SITUATION & LAYOUT R-350-12	
SECTION 3.1	
PROJECT NUMBER #SP-15-7(135)296	
SALT LAKE COUNTY	
DWG. NO. 3.1R-350-12.1	
SHT. 1 OF 8	

NOTES:
1) THE SHOULDER AREA BETWEEN THE CATCH BASINS AT STATIONS 5+062 AND 5+067 MUST BE GRADED TO CREATE POSITIVE DRAINAGE INTO THE BASINS, AND SO THAT THE LOW POINT IS AT THE BASINS.

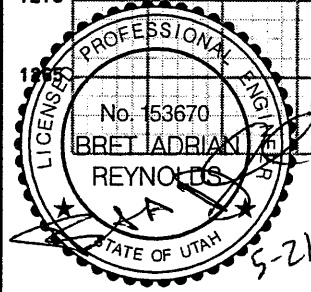
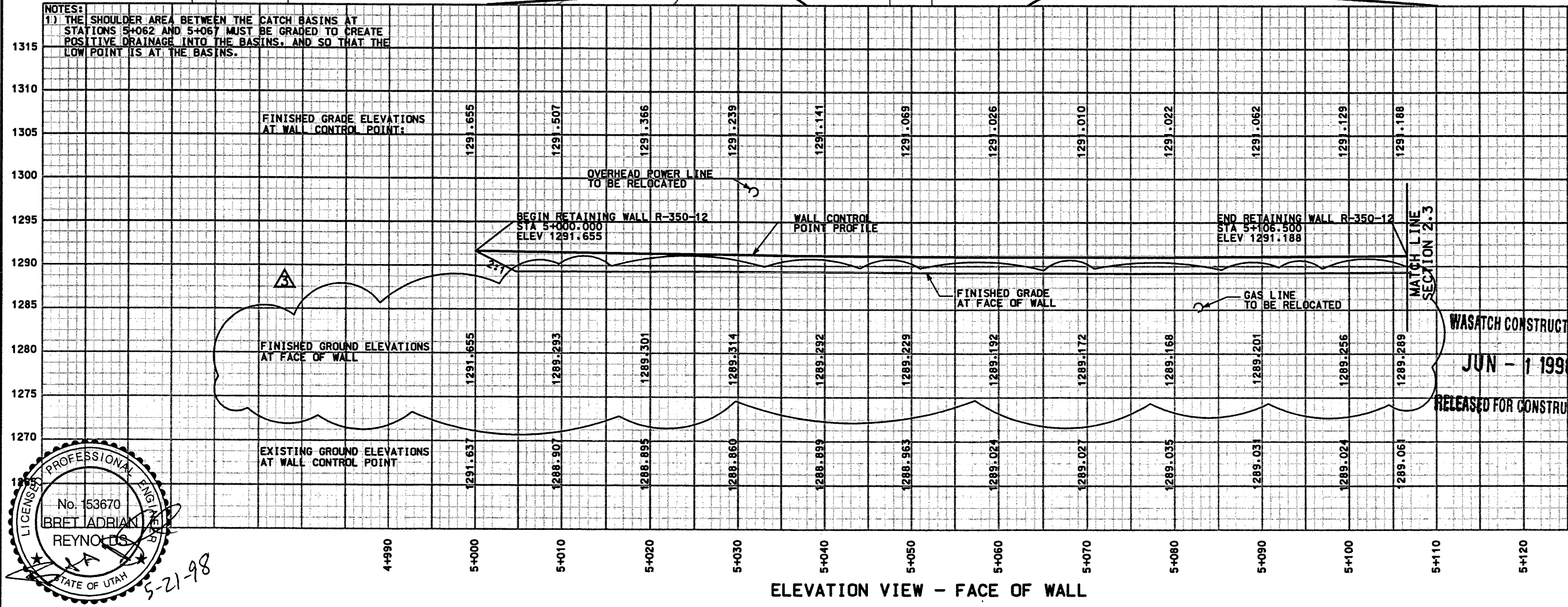

WASATCH CONSTRUCTORS
JUN - 1 1998
RELEASED FOR CONSTRUCTION

SEE NOTE 5
DWG. NO. 3.1-350-12.2

SEE NOTE 1

MATCH LINE
SECTION 2-3

13:1 FLARE-RATE
TEMPORARY CONCRETE
BARRIER

EXTEND TEMPORARY
BARRIER 1/1m
BEYOND EXISTING
EDGE OF PAVEMENT

STA 5+079.070
CS-18 CATCH BASIN
REQ'D

STA 5+060.432
CS-18 CATCH BASIN
REQ'D

STA 5+033.350
CS-18 CATCH BASIN
REQ'D

STA 4+995
CS-18
CATCH BASIN
REQ'D

BEGIN RETAINING WALL R-350-12
SBCD2 2+706.500 6.861 LT =
RETAINING WALL STA 5+000.000
N = 52092.253
E = 49953.291

END RETAINING WALL R-350-12
SBCD2 2+600.000 6.861 LT =
RETAINING WALL STA 5+106.500
N = 51985.813
E = 49949.696
MATCH RETAINING WALL 24-21
SECTION 2.3

RETAINING WALL DETAILS WALL R-350-12 (1-STAGE MSE WALL) N.T.S.

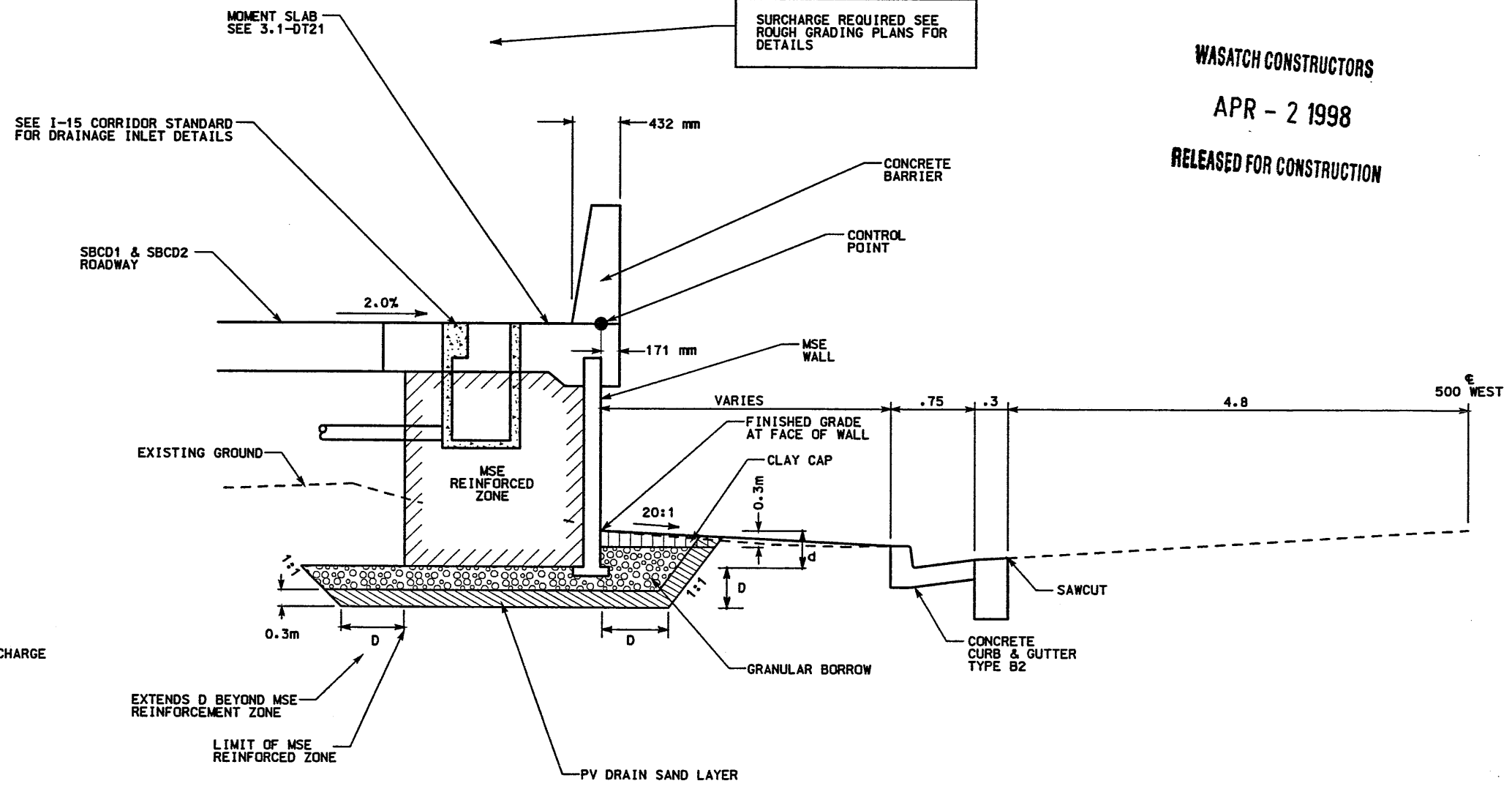

WASATCH CONSTRUCTORS
APR - 2 1998
RELEASED FOR CONSTRUCTION

NOTES:

- 1) OVEREXCAVATE EXISTING SOILS TO DEPTH (D) OF 1.0m MINIMUM OR AS SHOWN ON VSL PLANS.
- 2) CONSTRUCT CLAY CAP WITH LOW PLASTIC SILTY CLAY (0.3m THICK). CLAY CAP TO BE PLACED AFTER SURCHARGE HAS BEEN REMOVED.
- 3) SEE CORRIDOR STANDARD SPECIFICATION 221 FOR SPECIAL EXCAVATION REQUIREMENTS WHERE GROUNDWATER IS EXPECTED AT OR ABOVE THE REQUIRED EXCAVATION ELEVATION.
- 4) SEE CORRIDOR STANDARD SPECIFICATION 210 FOR SPECIAL EXCAVATION AND BACKFILL REQUIREMENTS WHERE SOFT CLAYS OR OTHER SOFT AND/OR WET CONDITIONS ARE ENCOUNTERED.
- 5) CONTRACTOR SHALL PROTECT SOUTH END OF WALL WITH TEMPORARY CONCRETE BARRIER AS REQUIRED FOR STAGE CONSTRUCTION OF 500 WEST AND WALL 24-21.

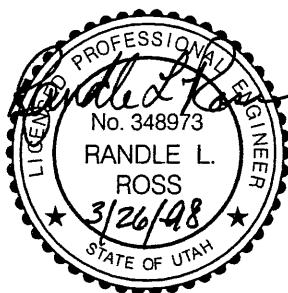

d = EMBEDMENT DEPTH (SEE VSL DETAILS)
D = DESIGN DEPTH OF STRUCTURAL FILL BENEATH WALL (SEE VSL DETAILS)

APPROVED FOR CONSTRUCTION		DESCRIPTION	
NO.	DATE	ORIGINAL ISSUE	
Δ	10/06/97	98 EARLY D/P/P	
Δ	3/25/98		
Δ	/ /		
Δ	/ /		
UTAH DEPARTMENT OF TRANSPORTATION MK O'BENTENIAL SVERDRUP/DE LEUW		DESIGN DMC	7/29/97
DESIGN	7/29/97	CHECK CJD	8/20/97
DRAWN	7/31/97	CHECK CJD	8/20/97
QUANT.	JBW	CHECK CJD	3/17/98
DESIGN	8/04/97	DATE	8/20/97
APPROVED	8/04/97	DATE	8/20/97
PROJECT DESIGN ENGINEER	Bret A. Reynolds	PROJECT MANAGER	Randle L. Ross
PROJECT NO.	3112300		
I-15 CORRIDOR RECONSTRUCTION WALL DETAIL R-350-12		SECTION 3.1	
PROJECT NUMBER		#SP-15-7(135)296	
SALT LAKE COUNTY		DWC. NO.	
3-R-350-12.2			
SHT.	2	OF	8
REF.			

E:\PROJECT\239-0007\13SERIES\13-112\RE-1

FINAL PLOT 10-01-97

APPROVED FOR CONSTRUCTION		
NO.	DATE	DESCRIPTION
1	10-01-97	RELEASE FOR CONSTRUCTION

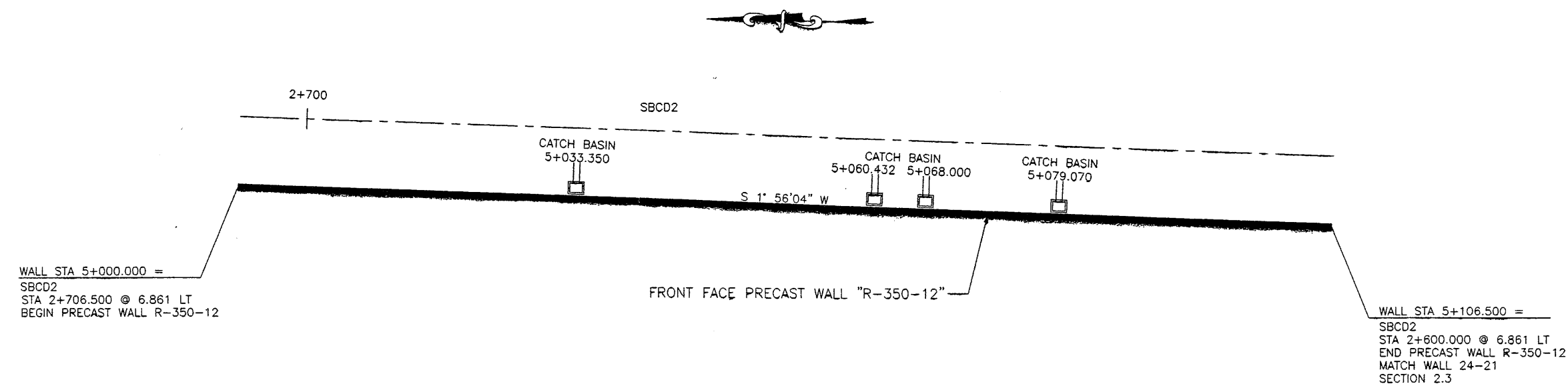

PLAN VIEW WALL "R-350-12"
 SCALE: 1=250 (FULL SIZE)
 SCALE: 1=500 (HALF SIZE)

GENERAL NOTES

- ALL WALLS ARE SHOWN FRONT FACE. NOTE STATIONING.
- PANEL TYPE IS DESIGNATED ON EACH PANEL. CONNECTOR LABELS INDICATE NUMBER OF CONNECTORS PER SOIL REINFORCING MESH LOCATION.
 EXAMPLE: 5B2-10 IS A "B2-10" PANEL WITH FIVE (5) CONNECTORS PER SOIL REINFORCING MESH LOCATION.
 IF NO CONNECTORS ARE SHOWN, FOUR (4) CONNECTOR PANELS SHALL BE USED:
- SOIL REINFORCING MESH TYPE IS DESIGNATED ON EACH PANEL. MESH LABELS INDICATE WIRE SIZE AND SPACING. LONGITUDINAL WIRE AND CROSSBAR SIZES ARE THE SAME UNLESS NOTED OTHERWISE:
 EXAMPLE: 4W11-6 MESH HAS FOUR (4) W11 LONGITUDINAL WIRES WITH W11 CROSSBARS AT 6" CENTERS.
 EXAMPLE: 5W11-6 MESH HAS FIVE (5) W11 LONGITUDINAL WIRES WITH W11 CROSSBARS AT 6" CENTERS.
- SEE RETAINED EARTH INSTALLATION MANUAL FOR PROPER WALL ERECTION PROCEDURES AND GUIDELINES.
- CONSTRUCTION PROCEDURES SHALL PREVENT BACKFILL SATURATION AND PONDING.
- HEAVY EQUIPMENT SHALL NOT BE USED WITHIN ONE METER OF THE BACK OF THE RETAINED EARTH PANELS. HAND COMPACTORS SHALL BE USED IN THIS AREA.
- CARE SHALL BE TAKEN TO PREVENT DAMAGE TO GALVANIZING. DAMAGED GALVANIZING SHALL BE COATED WITH ZINC RICH PAINT.
- BEARING PADS AND FILTER FABRIC ARE NOT REQUIRED BETWEEN THE LEVELING PAD AND THE FIRST ROW OF PANELS. TEMPORARY WEDGES MAY BE USED TO PROVIDE PROPER ALIGNMENT.
- VSL RETAINED EARTH IS PROTECTED UNDER U.S. PATENT 4,725,170.
- ALL PANELS SHALL HAVE AN ARCHITECTURAL FINISH, SEE SHEET RE-3 FOR DETAIL.

DESIGN PARAMETERS
ANGLE OF INTERNAL FRICTION (SELECT) = 34°
ANGLE OF INTERNAL FRICTION (BASE) = 30°
ANGLE OF INTERNAL FRICTION (RANDOM) = 34°
UNIT WEIGHT BACKFILL = 135 PCF.
TRAFFIC SURCHARGE = 250 PSF
SEISMIC ACCELERATION COFF. = 0.27g (TYP)
SEISMIC ACCELERATION COFF. = 0.68g (AT BRIDGE ABUTMENTS)
DESIGN CRITERIA
SAFETY FACTOR (OVERTURNING) = 2.0
SAFETY FACTOR (SLIDING) = 1.5
SAFETY FACTOR (PULLOUT) = 1.5
DESIGN LIFE = 75 YEARS

RETAINED EARTH INDEX
RE-1 PLAN PRECAST FACE WALL R-350-12, NOTES & DESIGN CRITERIA
RE-2 TYPICAL DETAILS
RE-3 TYPICAL DETAILS
RE-4 TYPICAL CROSS SECTIONS
RE-5 ELEVATION PRECAST WALL "R-350-12"
RE-6 SPECIAL PANEL DETAILS

WASATCH CONSTRUCTORS
 OCT 10 1997
 RELEASED FOR CONSTRUCTION

SHT 30FB
 METRIC

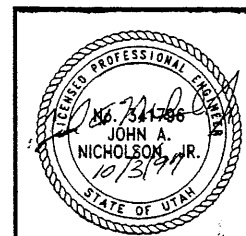

CERTIFIED FOR INTERNAL STABILITY OF RETAINED EARTH™ STRUCTURES ONLY. EXTERNAL STABILITY, INCLUDING BUT NOT LIMITED TO FOUNDATION AND SLOPE STABILITY, IS THE RESPONSIBILITY OF THE OWNER. DESIGN IS BASED ON THE ASSUMPTION THAT THE MATERIAL WITHIN THE RETAINED EARTH™ MASS, METHODS OF CONSTRUCTION, AND QUALITY OF PREFABRICATED MATERIALS CONFORM TO THE MANUFACTURER'S SPECIFICATION.

DES.	09-19-97	MM
DRN.	09-19-97	LOP
CHK.	09-19-97	MM

VSL CORPORATION
 2840 Rice Place, Suite 200
 Raleigh, NC 27612
 Telephone: (919) 781-6272
 Fax: (919) 781-4669

VSL

UTAH I-15 INTERCHANGE
 CANYON COUNTY, UTAH

SCALE: 3.1R-350-12
 JOB NO: 239-0007
 RE-1

E:\PROJECT\239-0007\13SERIES\13-112

10-01-97

FINAL

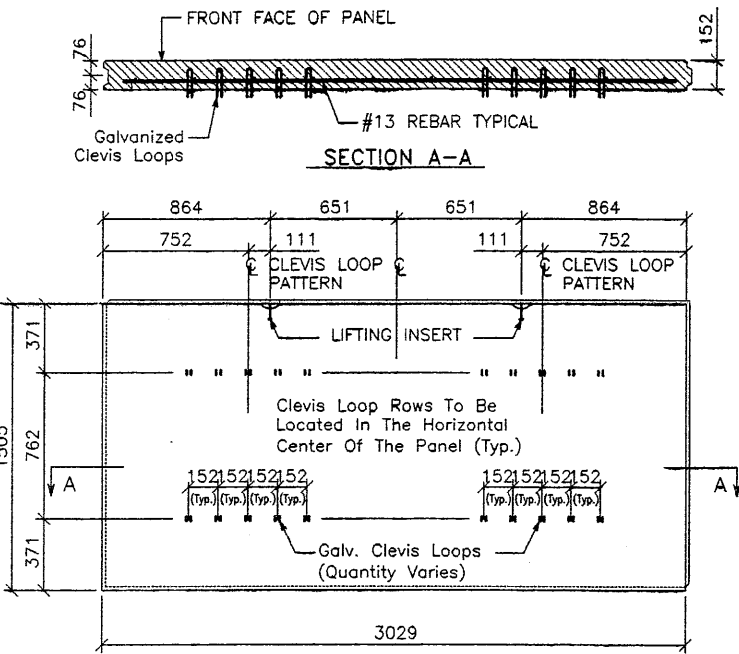

STANDARD "5A-10" PANEL Back Face View

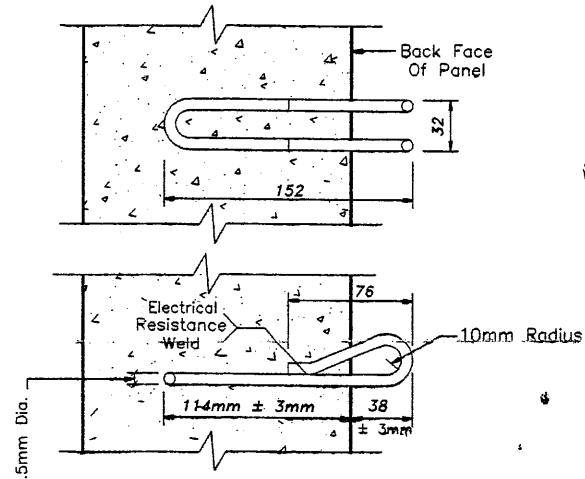
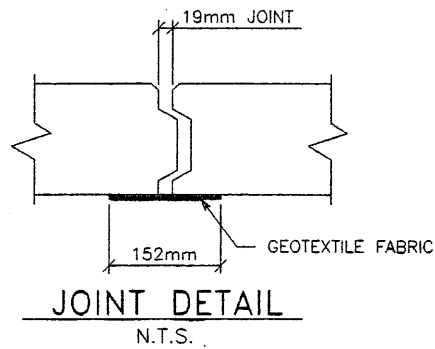

CLEVIS LOOP DETAIL N.T.S.

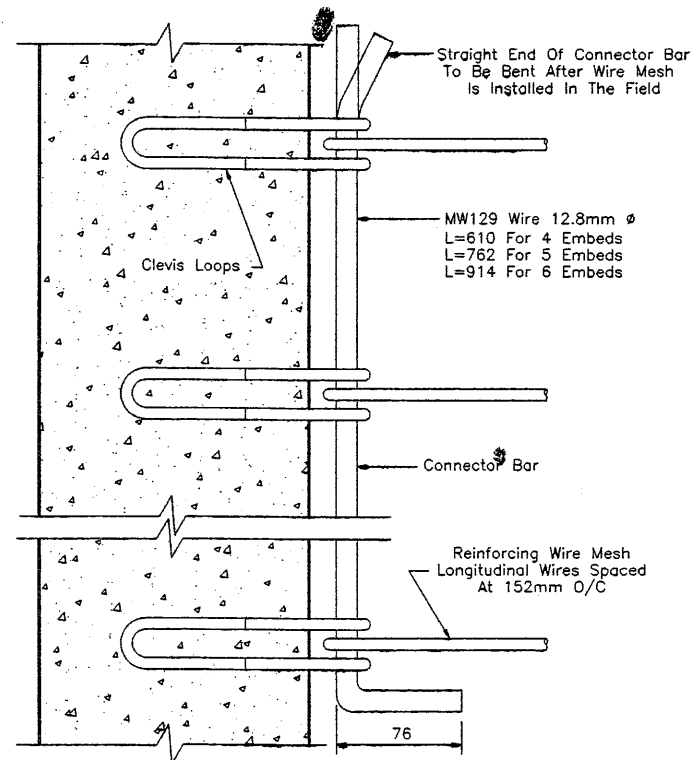

REINFORCING MESH CONNECTION DETAIL N.T.S.

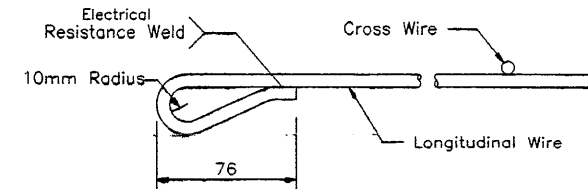

WIRE MESH LOOP DETAIL N.T.S.

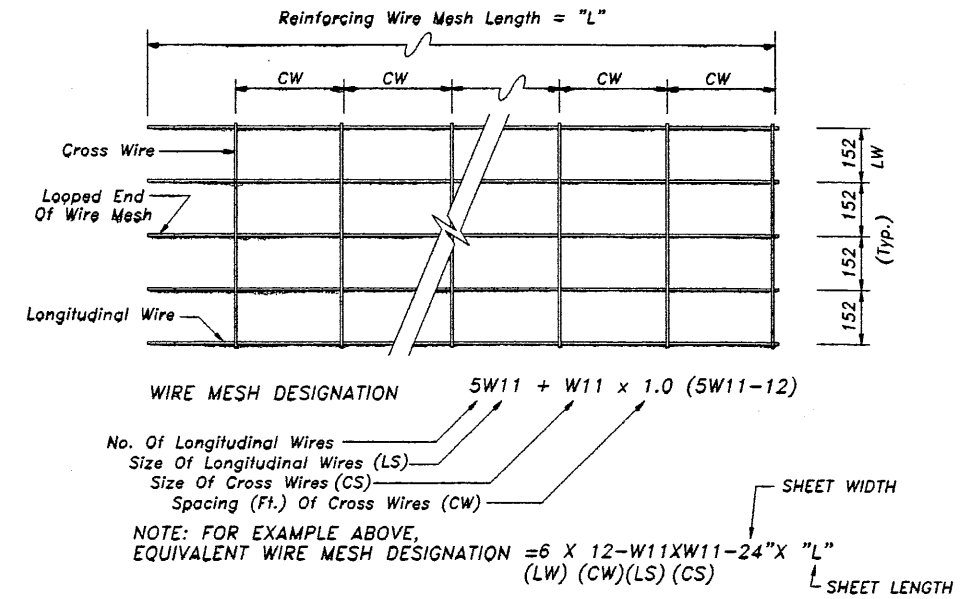

NOTE: W11 (71 sq mm) And W20 (129 sq mm) Steel Wire Material And Welding Of Cross Wires And Loops Shall Conform To ASTM A82 And ASTM 185, $F_y = 448$ MPa. Mesh Shall Be Galvanized To ASTM A-123 To A Minimum Effective Thickness Of 0.086 mm.

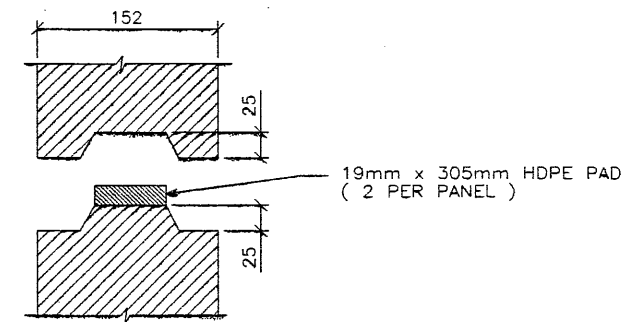

HORZ. JOINT DETAIL N.T.S.

CERTIFIED FOR INTERNAL STABILITY OF RETAINED EARTH™ STRUCTURES ONLY. EXTERNAL STABILITY, INCLUDING BUT NOT LIMITED TO FOUNDATION AND SLOPE STABILITY, IS THE RESPONSIBILITY OF THE OWNER. DESIGN IS BASED ON THE ASSUMPTION THAT THE MATERIAL WITHIN THE RETAINED EARTH™ MASS, METHODS OF CONSTRUCTION, AND QUALITY OF PREFABRICATED MATERIALS CONFORM TO THE MANUFACTURER'S SPECIFICATION.

APPROVED FOR CONSTRUCTION		
NO.	DATE	DESCRIPTION
△	10-01-97	RELEASE FOR CONSTRUCTION

WATCH CONSTRUCTORS
OCT 10 1997
RELEASED FOR CONSTRUCTION

DES.	09-19-97	MM	RETAINED EARTH™	NO.	DATE	BY	CHK
DRN.	09-19-97	LOP					
CHK.	09-19-97	MM					

VSL CORPORATION
2840 Plaza Place, Suite 200
Raleigh, NC 27612
Telephone: (919) 781-6272
Fax: (919) 781-4685

ALANTA, GA / DALLAS, TX / BALDWIN, NC (CORPORATE OFFICE)
MIAMI, FL / SAN JOSE, CA / SPRINGFIELD, VA

VSL

RETAINED EARTH™ WALLS
PRECAST WALL "R-350-12"
TYPICAL DETAILS

UTAH I-15 INTERCHANGE
SALT LAKE COUNTY, UTAH
UTAH DEPARTMENT OF TRANSP.

SCALE:
3.1R-350-12.4

JOB NO:
239-0007

RE-2

STATE OF UTAH
PROFESSIONAL ENGINEER
JOHN A. NICHOLSON, JR.
10/31/97

E:\PROJECT\239-0007\1SERIES\13-112\RE-3

FINAL PLAN 10-01-97

APPROVED FOR CONSTRUCTION		
NO.	DATE	DESCRIPTION
▲	10-01-97	RELEASE FOR CONSTRUCTION

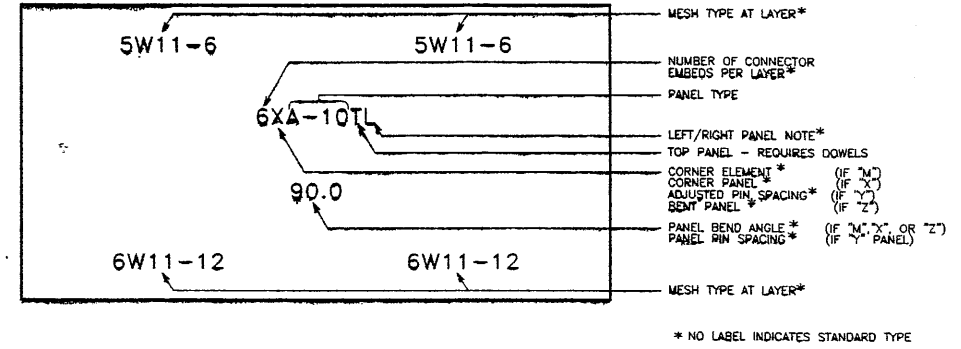
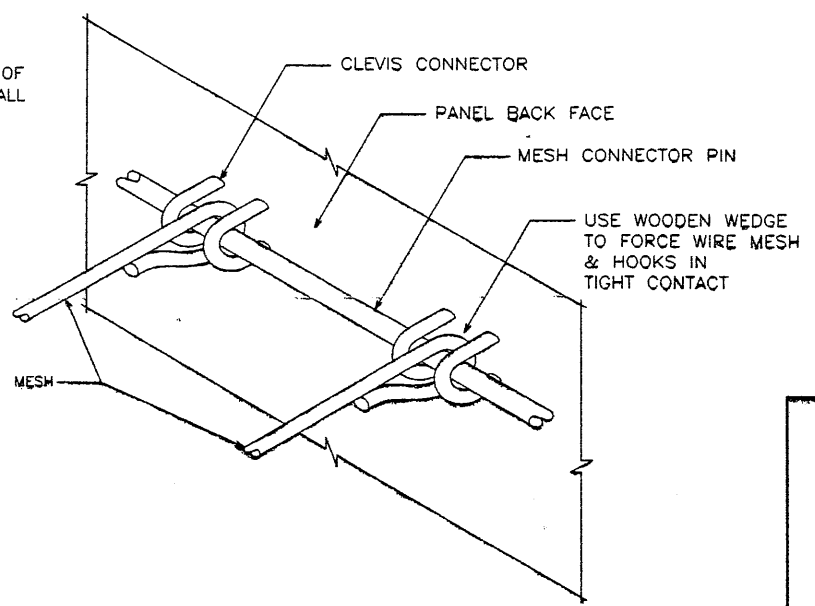
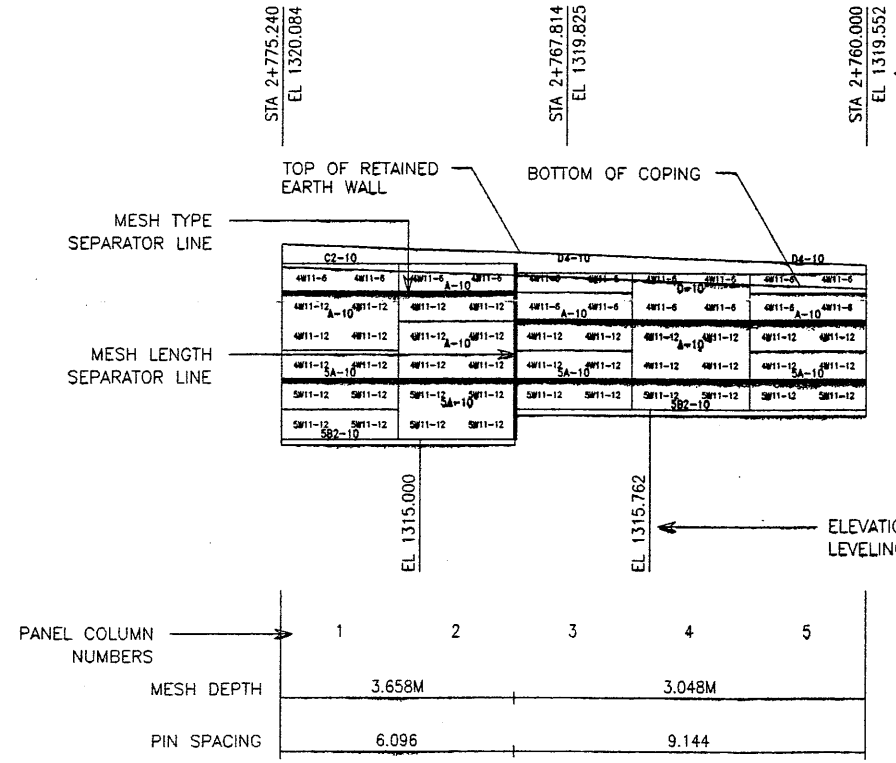

WASATCH CONSTRUCTORS
OCT 10 1997
RELEASED FOR CONSTRUCTION

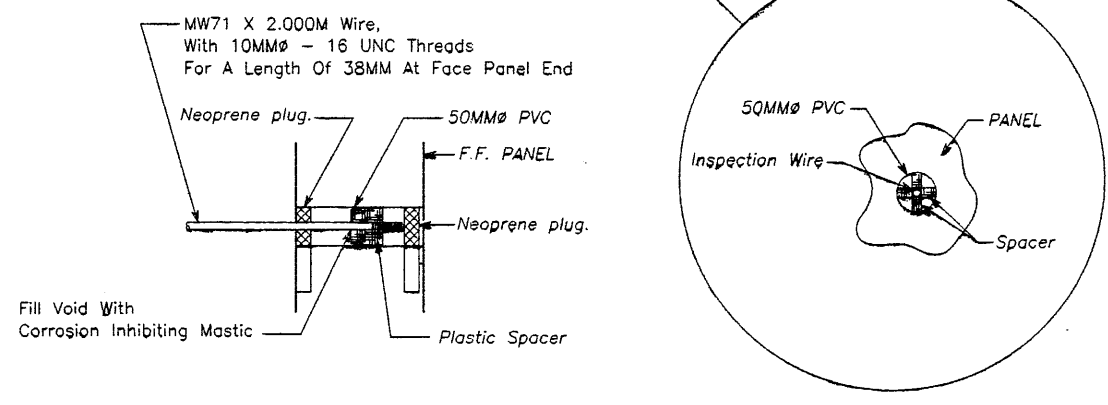
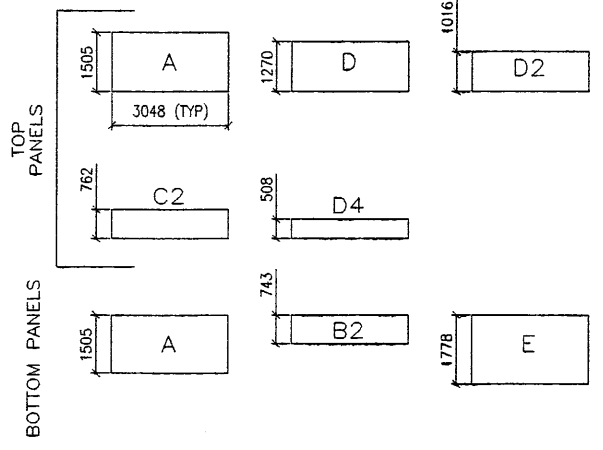
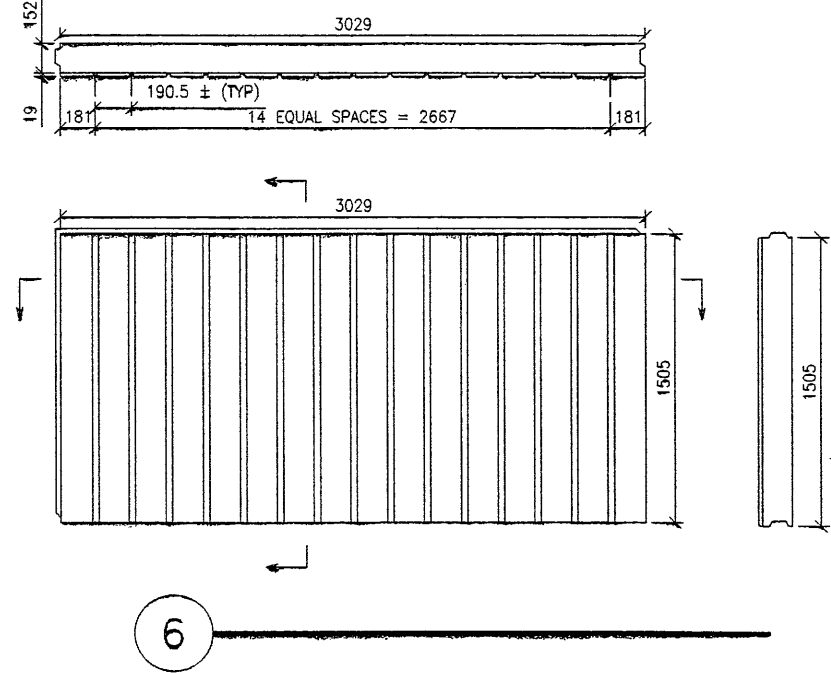
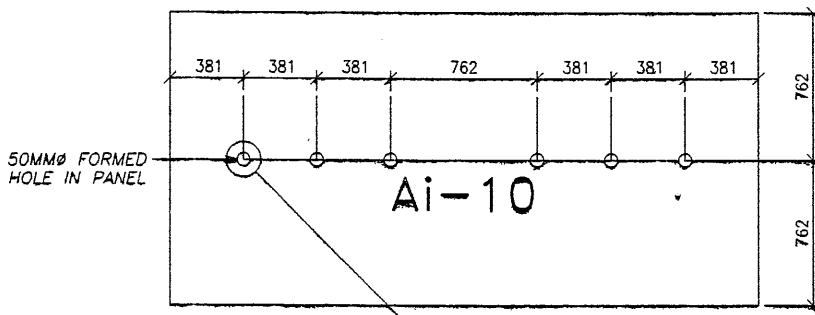

4 ALL DIMENSIONS ARE IN MILLIMETERS

5

CERTIFIED FOR INTERNAL STABILITY OF RETAINED EARTH™ STRUCTURES ONLY. EXTERNAL STABILITY, INCLUDING BUT NOT LIMITED TO FOUNDATION AND SLOPE STABILITY, IS THE RESPONSIBILITY OF THE OWNER. DESIGN IS BASED ON THE ASSUMPTION THAT THE MATERIAL WITHIN THE RETAINED EARTH™ MASS, METHODS OF CONSTRUCTION, AND QUALITY OF PREFABRICATED MATERIALS CONFORM TO THE MANUFACTURER'S SPECIFICATION.

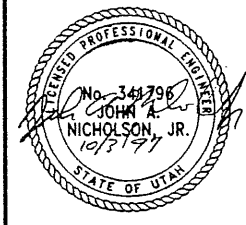

RETAINED EARTH™ WALLS
PRECAST WALL "R-350-12"
TYPICAL DETAILS
UTAH I-15 INTERCHANGE
SALT LAKE COUNTY, UTAH

SCALE: 3.1R-350-12.5
JOB NO: 239-0007
RE-3

VSL CORPORATION
2840 Plaza Place, Suite 200
Tomball, TX (936) 761-6272
Fax: (936) 761-6688

DES. 09-19-97 MM
DRN. 09-19-97 LOP
CHK. 09-19-97 MM

NO LABEL INDICATES STANDARD TYPE

E:\PROJECT\239-0007\13SERIES\13-112

0-06-97

FINAL 1

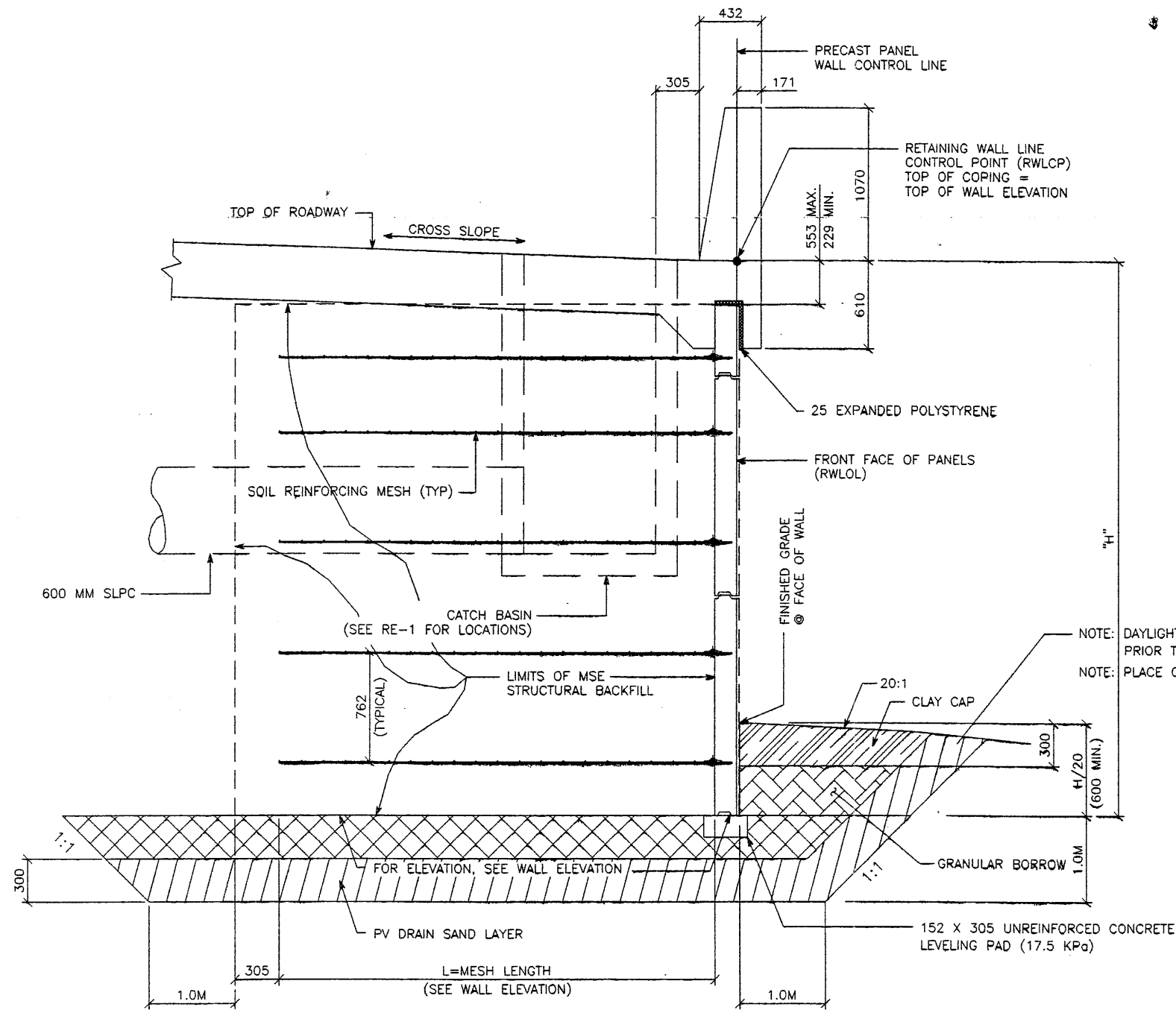

TYPICAL CROSS SECTION
 SCALE: 1:20 (FULL SIZE)
 SCALE: 1:40 (HALF SIZE)

NOTE: DAYLIGHT PV SAND LAYER PRIOR TO PLACING CLAY CAP
 NOTE: PLACE CLAY CAP AFTER PRIMARY SETTLEMENT

APPROVED FOR CONSTRUCTION		
NO.	DATE	DESCRIPTION
1	10-01-97	RELEASE FOR CONSTRUCTION

DES.	DRN.	CHK.	NO.	DATE	DESCRIPTION

VSL CORPORATION
 2840 First Place, Suite 200
 Raleigh, NC 27612
 Telephone: (919) 781-8272
 Fax: (919) 781-4863

WASATCH CONSTRUCTORS
 OCT 10 1997
 RELEASED FOR CONSTRUCTION

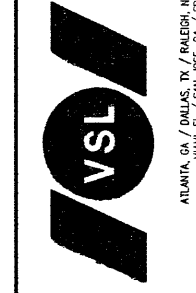

VSL Corporation (VSL) is not responsible for the design or construction of any structure or for the use of any material or method of construction which is not specifically approved by VSL. The use of any material or method of construction which is not specifically approved by VSL is the responsibility of the owner. Any other use is strictly the responsibility of the user. VSL DISCLAIMS LIABILITY FOR SUCH USE.

RETAINED EARTH™ WALLS
 WIRE FACED WALL "R-350-12"
 TYPICAL CROSS SECTION
 UTAH I-15 INTERCHANGE
 SALT LAKE COUNTY, UTAH
 UTAH DEPARTMENT OF TRANSP.

SHT 6 OF 8
 METRIC

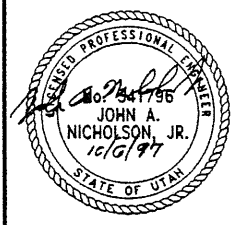

CERTIFIED FOR INTERNAL STABILITY OF RETAINED EARTH™ STRUCTURES ONLY. EXTERNAL STABILITY, INCLUDING BUT NOT LIMITED TO FOUNDATION AND SLOPE STABILITY, IS THE RESPONSIBILITY OF THE OWNER. DESIGN IS BASED ON THE ASSUMPTION THAT THE MATERIAL WITHIN THE RETAINED EARTH™ MASS, METHODS OF CONSTRUCTION, AND QUALITY OF PREFABRICATED MATERIALS CONFORM TO THE MANUFACTURER'S SPECIFICATION.

SCALE:	3.1R-350-12.6
JOB NO.:	239-0007
	RE-4

E:\PROJECT\239-0007\13SERIES\13-112\W13-11Z

FINAL PLAN 10-01-97

BEGIN WALL R-350-12
WALL STA 5+000.000 =
SBOD2
STA 2+706.500 @ 6.861 LT
NOMINAL PANEL FACE (RWLOL)

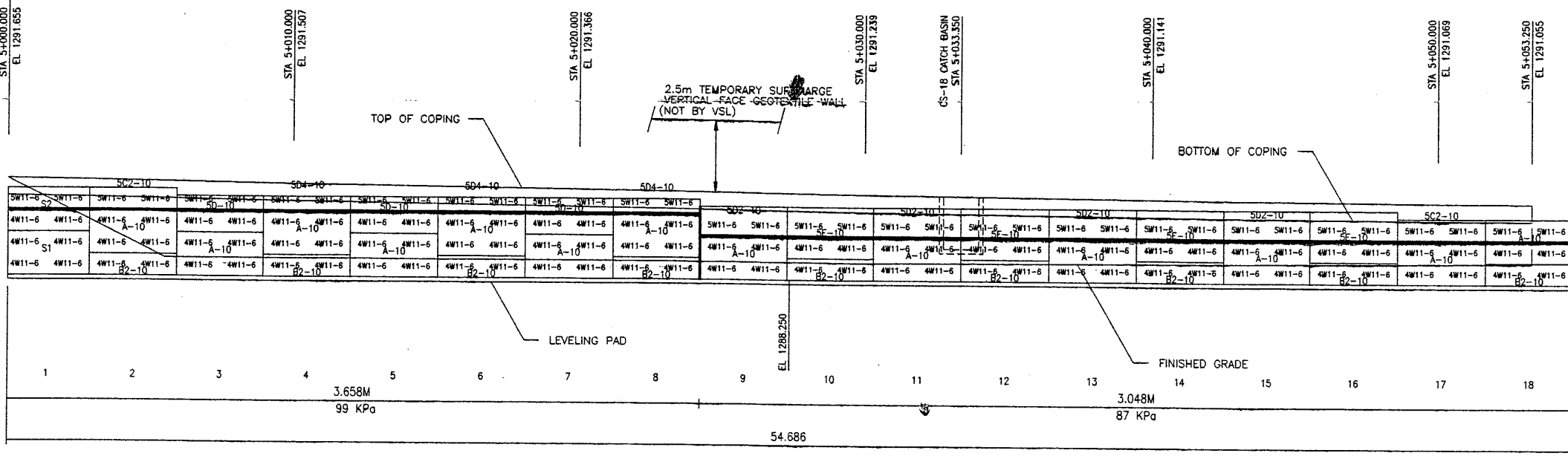

ELEVATION PRECAST WALL R-350-12
(FRONT FACE SHOWN) SCALE 1:100 (FULL SIZE)
(TOTAL SURFACE AREA OF PANELS = 267.42 SM) SCALE 1:200 (HALF SIZE)

END WALL R-350-12
WALL STA 5+106.500 =
SBOD2
STA 2+600.000 @ 6.861 LT
NOMINAL PANEL FACE (RWLOL)
MATCH WALL 24-21
SECTION 2.3

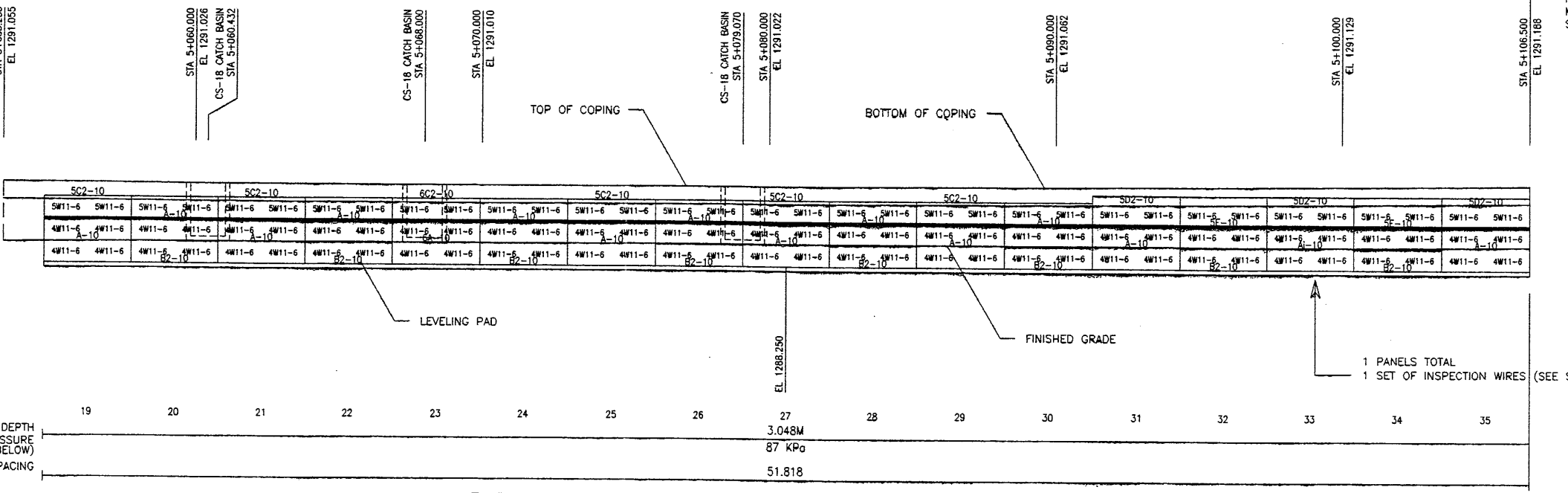

ELEVATION PRECAST WALL R-350-12
(FRONT FACE SHOWN) SCALE 1:100 (FULL SIZE)
(TOTAL SURFACE AREA OF PANELS = 267.42 SM) SCALE 1:200 (HALF SIZE)

1 PANELS TOTAL
1 SET OF INSPECTION WIRES (SEE SHEET RE-3)

SHT 7 OF 8
METRIC

APPROVED FOR CONSTRUCTION		
NO.	DATE	DESCRIPTION
△	10-01-97	RELEASE FOR CONSTRUCTION

WASATCH CONSTRUCTORS
OCT 10 1997
RELEASED FOR CONSTRUCTION

DES.	MM	LOP	MM
09-19-97			
09-19-97			
09-19-97			

VSL CORPORATION
2840 Plaza Place, Suite 200
Raleigh, NC 27612
Telephone: (919) 781-6272
Fax: (919) 781-6869



VSL Corporation (VSL) claims a proprietary right in all designs, specifications, drawings, and other documents prepared by or for VSL. The use of these documents without the written consent of VSL is prohibited. Any other use is strictly prohibited.

RETAINED EARTH™ WALLS
PRECAST WALL "R-350-12"
I-15 INTERCHANGE
SALT LAKE COUNTY, UTAH

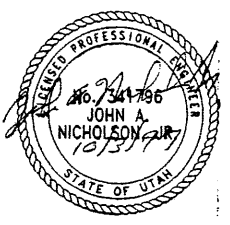

CERTIFIED FOR INTERNAL STABILITY OF RETAINED EARTH™ STRUCTURES ONLY. EXTERNAL STABILITY, INCLUDING BUT NOT LIMITED TO FOUNDATION AND SLOPE STABILITY, IS THE RESPONSIBILITY OF THE OWNER. DESIGN IS BASED ON THE ASSUMPTION THAT THE MATERIAL WITHIN THE RETAINED EARTH™ MASS, METHODS OF CONSTRUCTION, AND QUALITY OF PREFABRICATED MATERIALS CONFORM TO THE MANUFACTURER'S SPECIFICATION.

SCALE:	3.1R-350-12.7
JOB NO:	239-0007
	RE-5

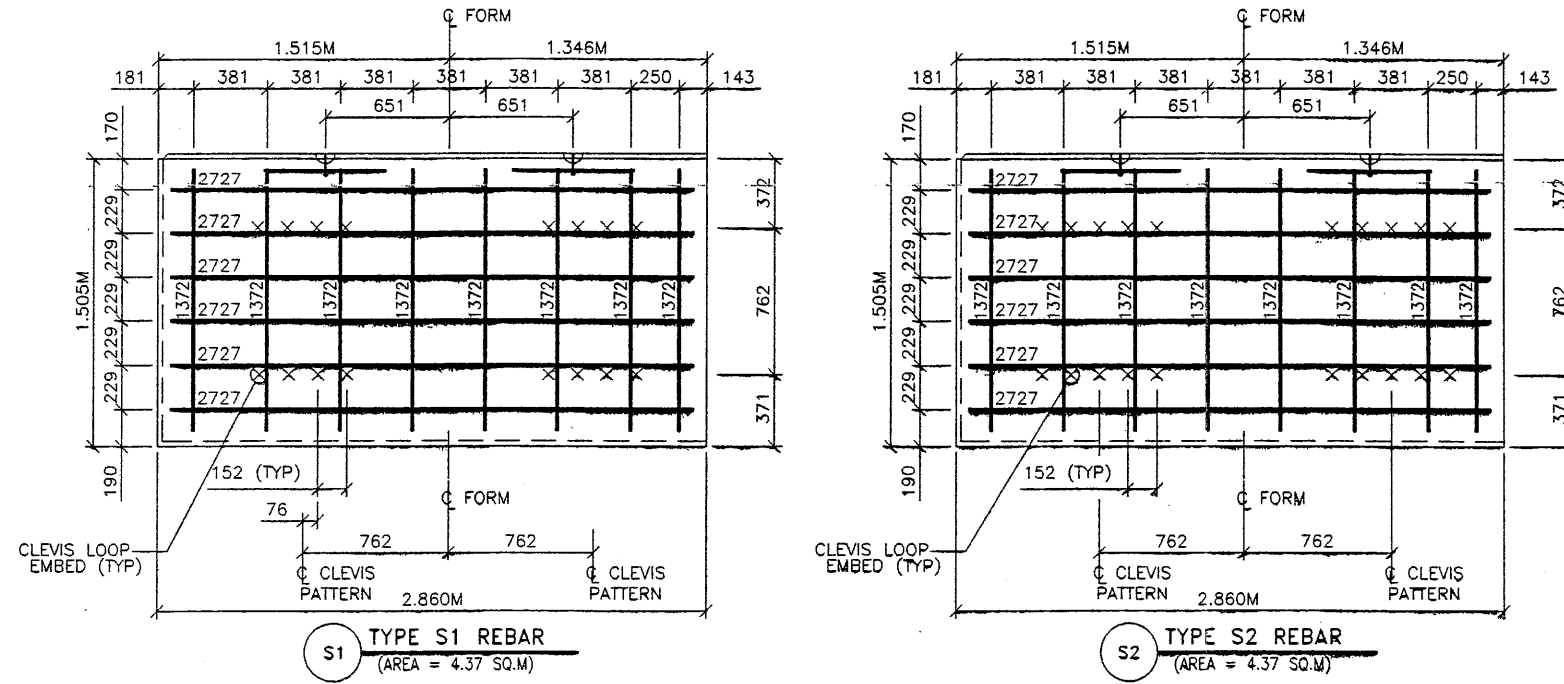

S1 TYPE S1 REBAR
(AREA = 4.37 SQ.M)

S2 TYPE S2 REBAR
(AREA = 4.37 SQ.M)

APPROVED FOR CONSTRUCTION		
NO.	DATE	DESCRIPTION
1	10-01-97	RELEASE FOR CONSTRUCTION

- PANEL REINFORCEMENT NOTES:
1. PANELS ARE SHOWN BACK FACE.
 2. HORIZONTAL REINFORCEMENT SHALL HAVE 50 mm MINIMUM COVER TO THE BACK FACE.
 3. ALL REINFORCEMENT SHALL HAVE 50 mm MINIMUM COVER TO THE SIDES.
 4. ALL REINFORCING BARS ARE #13 METRIC. LABELS ON EACH BAR INDICATE LENGTH. EXAMPLE: 1345 IS A #13 BAR 1345 mm LONG.
 5. PANEL REINFORCEMENT BARS SHALL BE DEFORMED BILLET STEEL BARS FOR CONCRETE REINFORCEMENT CONFORMING TO THE SPECIFICATIONS OF ASTM DESIGNATION A615, GRADE 60.
 6. ALL REINFORCING STEEL TO BE GALVANIZED IN ACCORDANCE WITH ASTM 767 CLASS 1.
 7. CONCRETE PANELS TO HAVE 28 DAY COMPRESSIVE STRENGTH OF 27,500 KPa.
 8. EQUIVALENT WELDED WIRE FABRIC MAY BE USED.
 9. ALL PANELS TO USE 9.5mmØ CLEVIS LOOPS.
 10. VSL RETAINED EARTH™ IS PROTECTED UNDER PATENT 4,725,170.

WASATCH CONSTRUCTORS
OCT 10 1997
RELEASED FOR CONSTRUCTION

VSL CORPORATION
3840 Park Plaza, Suite 200
Raleigh, NC 27612
Telephone: (919) 761-6272
Fax: (919) 761-4869



VSL Corporation (VSL) is a registered trademark of VSL Corporation. All rights reserved. VSL Corporation is not responsible for any errors or omissions in this document. The use of any information in this document is made at the user's discretion. VSL Corporation is not responsible for any damage or injury to the user or any other person or property resulting from the use of this document. VSL Corporation is not responsible for any damage or injury to the user or any other person or property resulting from the use of this document.

SHT BOFB
METRIC

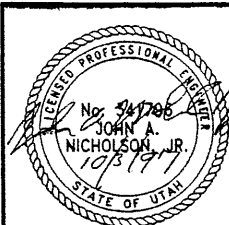

CERTIFIED FOR INTERNAL STABILITY OF RETAINED EARTH™ STRUCTURES ONLY. EXTERNAL STABILITY, INCLUDING BUT NOT LIMITED TO FOUNDATION AND SLOPE STABILITY, IS THE RESPONSIBILITY OF THE OWNER. DESIGN IS BASED ON THE ASSUMPTION THAT THE MATERIAL WITHIN THE RETAINED EARTH™ MASS, METHODS OF CONSTRUCTION, AND QUALITY OF PREFABRICATED MATERIALS CONFORM TO THE MANUFACTURER'S SPECIFICATION.

RETAINED EARTH™ WALLS
PRECAST WALL "R-350-12"
SPECIAL PANEL REINFORCEMENT
UTAH I-15 INTERCHANGE
SALT LAKE COUNTY, UTAH
UTAH DEPARTMENT OF TRANSP.

SCALE:
3.1R-350-12.8
JOB NO:
239-0007
RE-6

User: rmm: alimmon/h
Date: 02-FEB-1999 Time: 11:18

Filename: c:\dgn\115_cadd\13_97_fcc_99\sheet_30_retwall-h.dwg

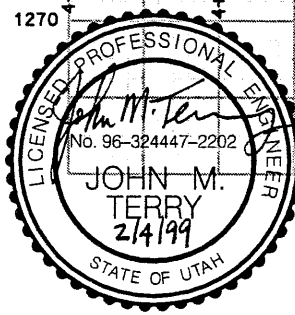
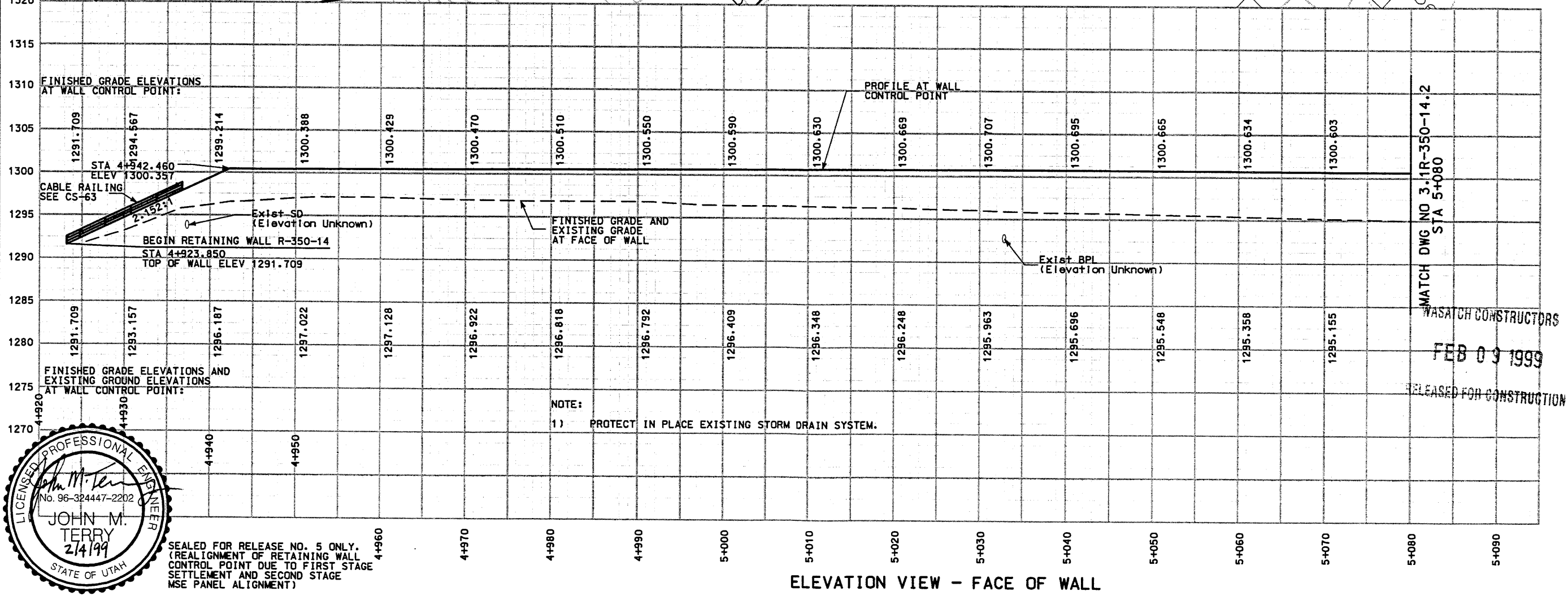
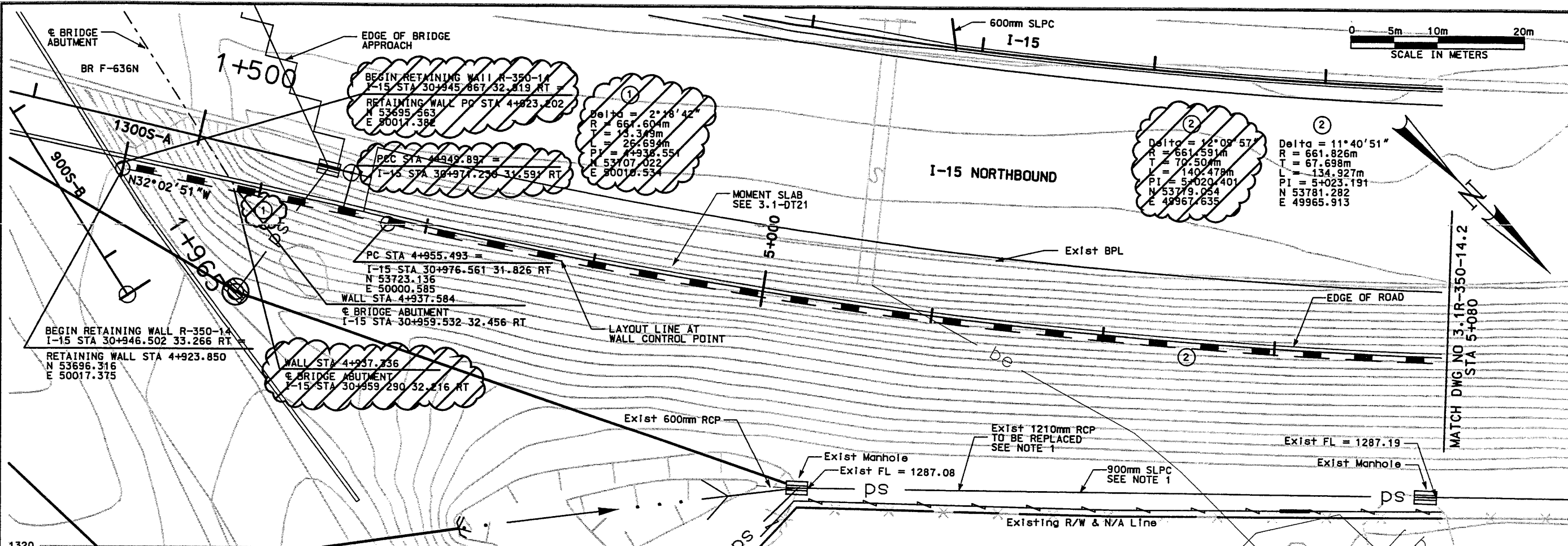

SEALED FOR RELEASE NO. 5 ONLY.
(REALIGNMENT OF RETAINING WALL
CONTROL POINT DUE TO FIRST STAGE
SETTLEMENT AND SECOND STAGE
MSE PANEL ALIGNMENT)

ELEVATION VIEW - FACE OF WALL

APPROVED FOR CONSTRUCTION		DESCRIPTION	
NO.	DATE	ADD & BRIDGE/FACE OF WALL INTERSECTION	
▲	11/03/97	98 EARLY C/D/P	
▲	3/25/98	NOC - 0259	
▲	10/25/98	RELEASE FOR 2ND STAGE CONSTRUCTION	
▲	02/02/99		
UTAH DEPARTMENT OF TRANSPORTATION MK CENTENNIAL SVERDRUP/DE LEUW		DESIGN DMC	8/04/97
DESIGN	Bret A. Reynolds	CHECK C/D	8/04/97
DRAWN	MVM	CHECK C/D	8/04/97
QUANT.	JBW	CHECK C/D	3/19/98
APPROVAL	8/04/97	DATE	
RECORD	8/04/97	DATE	
PROJECT DESIGN ENGINEER	Bret A. Reynolds		
PROJECT MANAGER	Randie L. Ross		
PROJECT NUMBER	#SP-15-7(135)296		
I-15 CORRIDOR RECONSTRUCTION SITUATION & LAYOUT R-350-14 SECTION 3.1		WBS NO.	3112410
SALT LAKE COUNTY			
DWG. NO. 3.1R-350-14.1			
SHT.	1	OF	12
REF.			

RFC After Final Approval

User: webbjb
 Date: 05-OCT-1998 Time: 11:52
 Filename: c:\p115_cadd\13_97\sheet_13_files\wall13_rctwall14.dgn

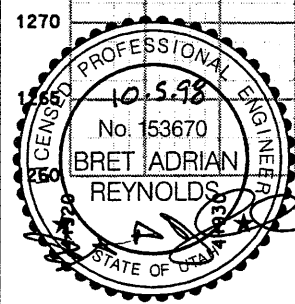
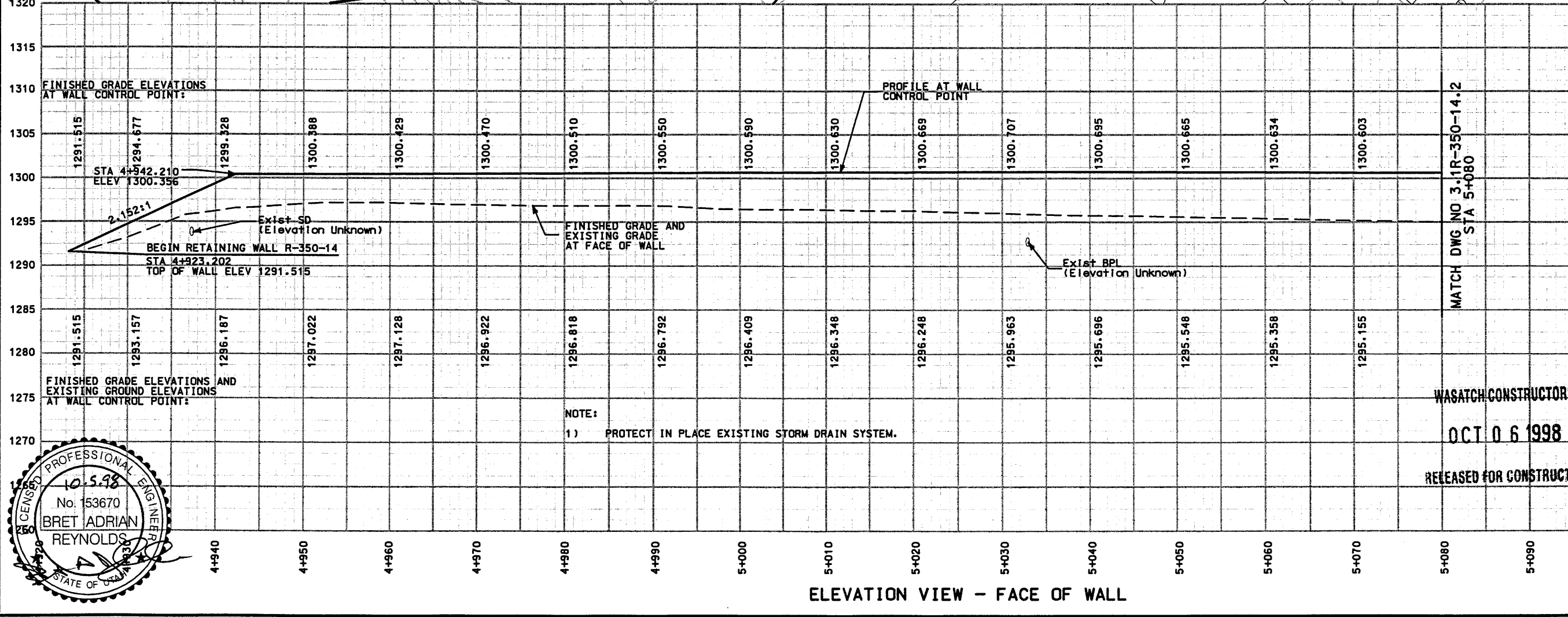
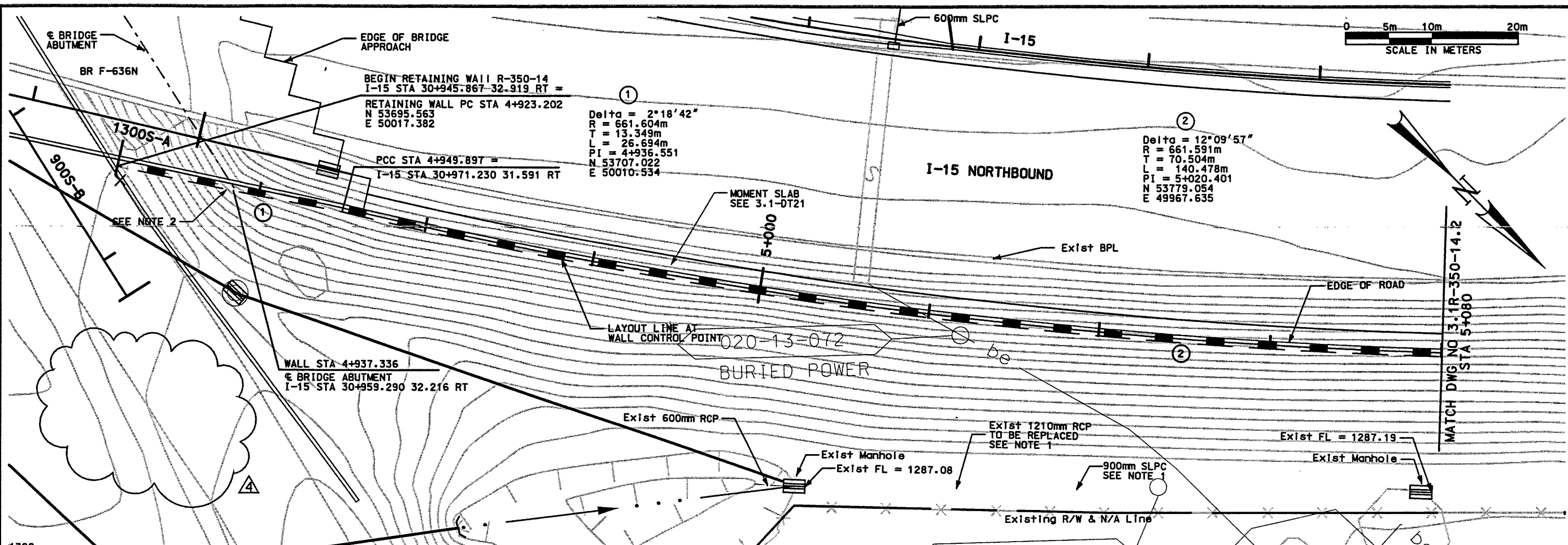

WASATCH CONSTRUCTORS
 OCT 06 1998
 RELEASED FOR CONSTRUCTION

APPROVED FOR CONSTRUCTION	
NO.	DATE
1	8/04/97
2	11/03/97
3	3/25/98
4	10/05/98
DESCRIPTION	
1	ORIGINAL ISSUE
2	ADD & BRIDGE FACE OF WALL INTERSECTION
3	98 EARLY C/D/P
4	INC - 0253
UTAH DEPARTMENT OF TRANSPORTATION MK CENTENNIAL S/VERDRUP/DE LEUW	
APPROVAL RECORD:	DESIGN DMC 7/29/97
8/04/97	8/04/97
Bret A. Reynolds	PROJECT DESIGN ENGINEER
DATE	DATE
8/04/97	7/31/97
APPROVED	8/04/97
8/04/97	3/17/98
Randle L. Ross	PROJECT MANAGER
DATE	DATE
8/04/97	3/17/98
WBS NO.	3112600
I-15 CORRIDOR RECONSTRUCTION SITUATION & LAYOUT R-350-14 SECTION 3.1 PROJECT NUMBER #SP-15-1(135)296	
SALT LAKE COUNTY DWG. NO. 3.1R-350-14.1	
SHT. 1 OF 12	
REF.	

Date: 22-DEC-99 Times: 08:46

Filename: c:\pdp\115_cadd\13_37\13_37.dwg, 99 sheet, files\valia\3_rstval-h_027.dwg

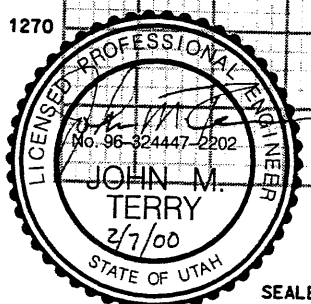
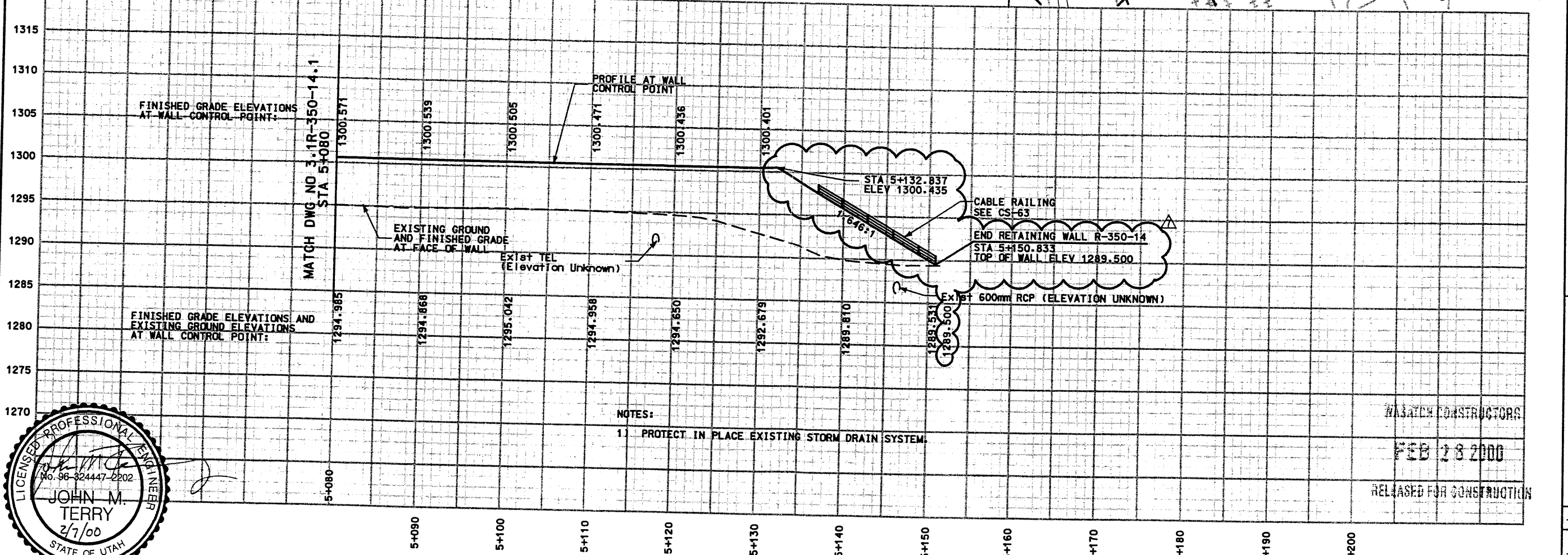
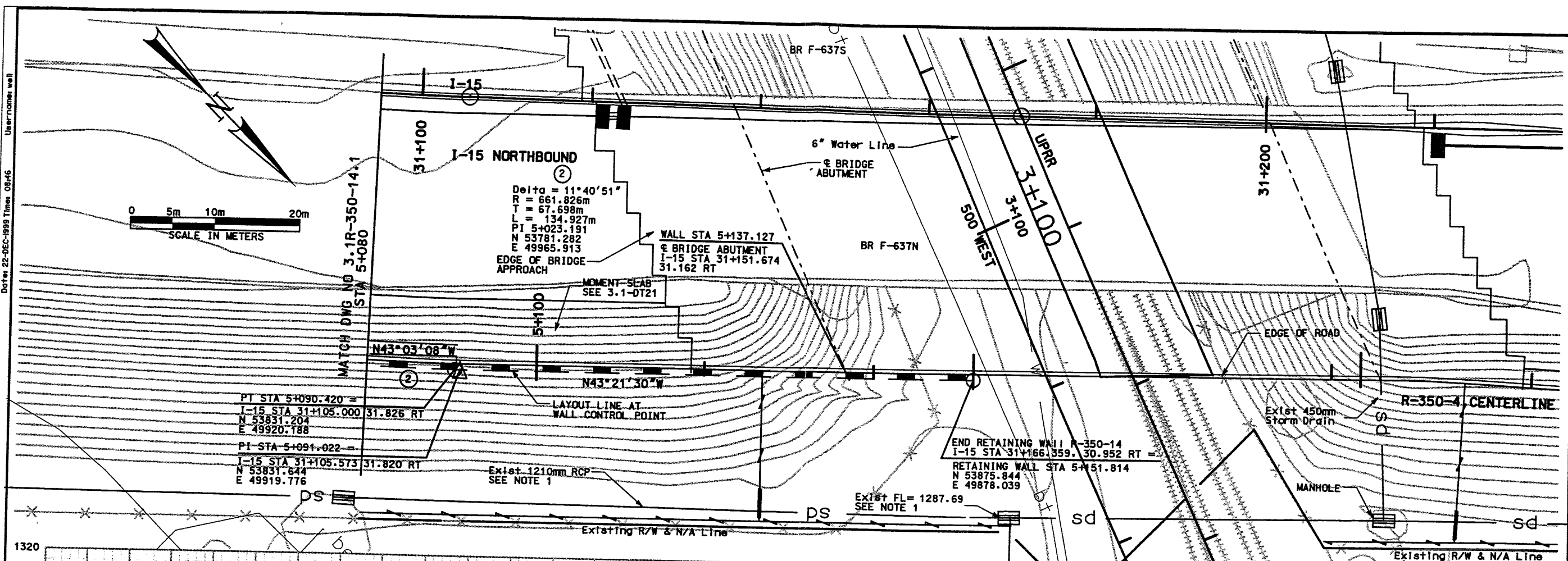

SEALED FOR RELEASE NO. 7 ONLY.

- NOTES:
- 1) PROTECT IN PLACE EXISTING STORM DRAIN SYSTEM.

RELEASED FOR CONSTRUCTION
 FEB 28 2000
 HASATCH CONSTRUCTORS

APPROVED FOR CONSTRUCTION	
NO.	DESCRIPTION
10/28/98	HDC - 0274
02/02/99	RELEASE FOR 2ND STAGE CONSTRUCTION
12/22/99	REVISED PROFILE PER REF 5-0441
1/1	
UTAH DEPARTMENT OF TRANSPORTATION MK CENTENNIAL SVERDRUP/DE LEUW	
DESIGN DMC	1/29/97
CHECK CJD	8/04/97
DESIGN MVM	1/31/97
CHECK CJD	8/04/97
QUANT. JBN	3/17/98
CHECK CJD	3/19/98
DESIGN DATE	1/29/97
PROJECT DESIGN ENGINEER	Bret A. Reynolds
DATE	8/04/97
PROJECT MANAGER	Randall L. Robb
DATE	3/17/98
DESIGN NO.	3112410
WBS NO.	3112410
I-15 CORRIDOR RECONSTRUCTION SITUATION & LAYOUT R-350-14 SECTION 3.1	
PROJECT NUMBER	#SP-15-7(135)296
SALT LAKE COUNTY DWG. NO. 3.1R-350-14.2	
SHT.	2 OF 12
REF.	

RFC After Final Approval

Username: webb/jb
 Date: 28-OCT-1998 Time: 11:39
 Filename: c:\vgn\us_cadd\13_97\sheet_files\13_rstvol14_02.dgn

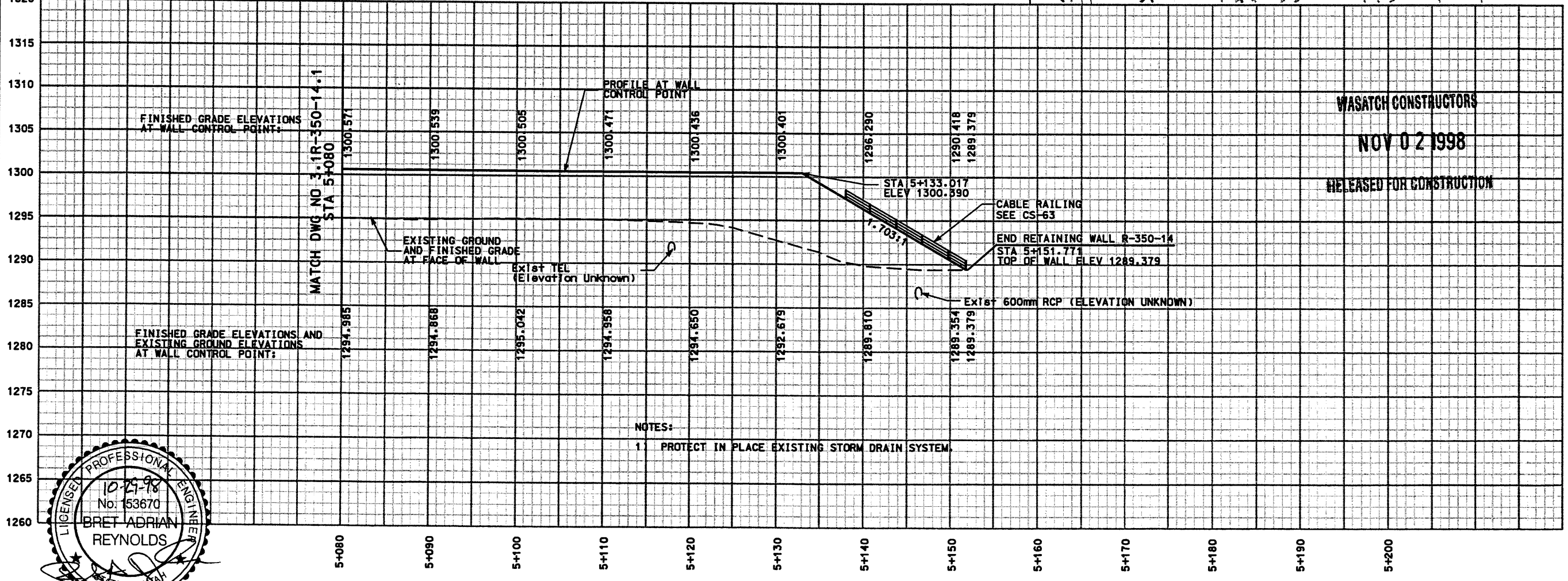
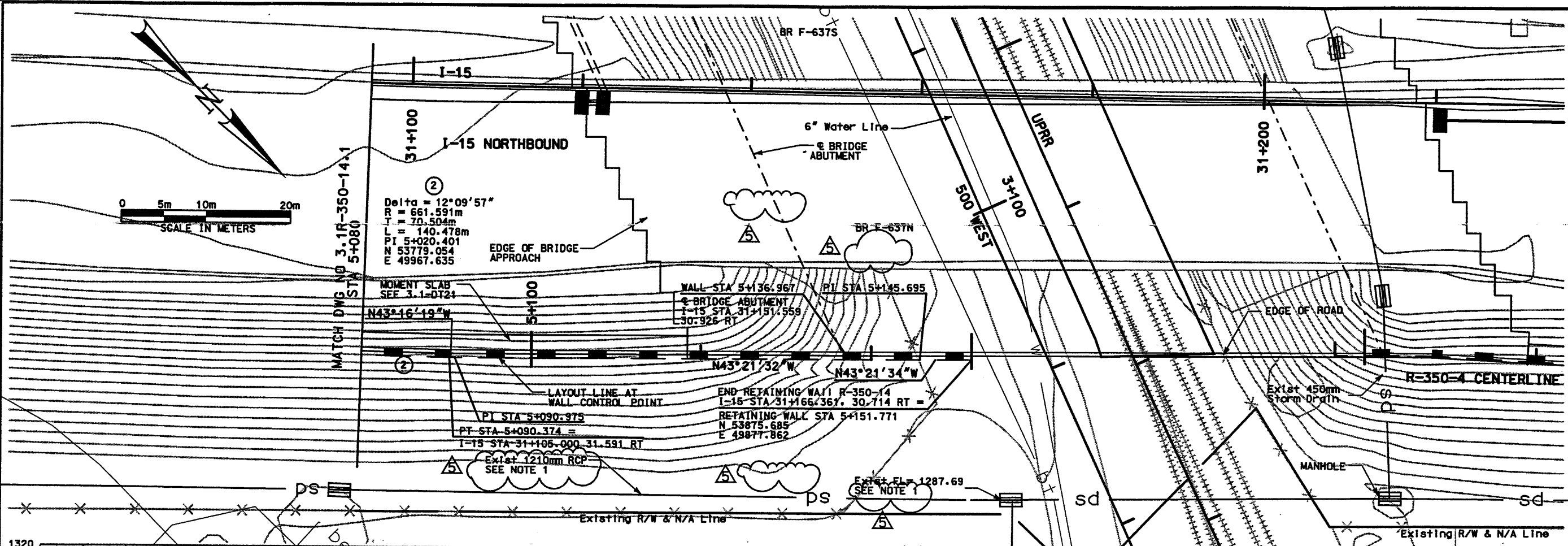

ELEVATION VIEW - FACE OF WALL

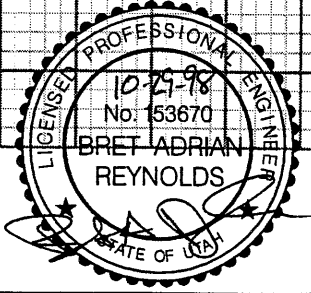

APPROVED FOR CONSTRUCTION		DESCRIPTION	
NO.	DATE	NO.	DATE
Δ	10/28/98	Δ	10/28/98
Δ	11/11/98	Δ	11/11/98
Δ	11/11/98	Δ	11/11/98
Δ	11/11/98	Δ	11/11/98
UTAH DEPARTMENT OF TRANSPORTATION		WBS NO.	
MK CENTENNIAL		3112600	
SVERDRUP/DE LEUW		DESIGN DMC 1/29/97	
Bret A. Reynolds		CHECK CJD 8/04/97	
PROJECT DESIGN ENGINEER		DRAWN MWN 1/31/97	
DATE 8/04/97		CHECK CJD 8/04/97	
Randle L. Ross		QUANT. JBW 3/17/98	
PROJECT MANAGER		CHECK CJD 3/19/98	
DATE 8/04/97			
I-15 CORRIDOR RECONSTRUCTION		SECTION 3.1	
SITUATION & LAYOUT R-350-14		PROJECT NUMBER	
		#SP-15-7(135)296	
SALT LAKE COUNTY		COUNTY	
DWG. NO.		DWG. NO.	
3.1R-350-14.2		3.1R-350-14.2	
SHT. 2 OF 12			
REF.			

WASATCH CONSTRUCTORS
 NOV 02 1998
 RELEASED FOR CONSTRUCTION

User: name.simonjh Date: 02-FEB-1999 Time: 12:27

RETAINING WALL DETAILS

WALL R-350-14
(2-STAGE MSE WALL)
NTS

SURCHARGE REQUIRED SEE
ROUGH GRADING PLANS FOR DETAILS

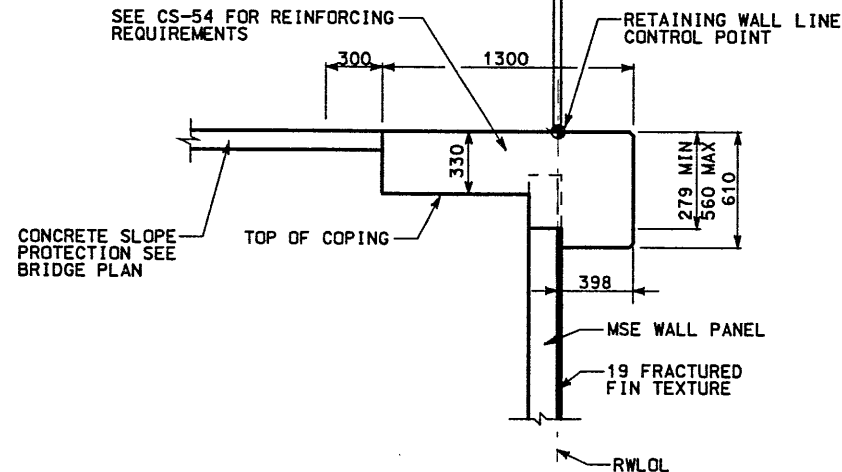
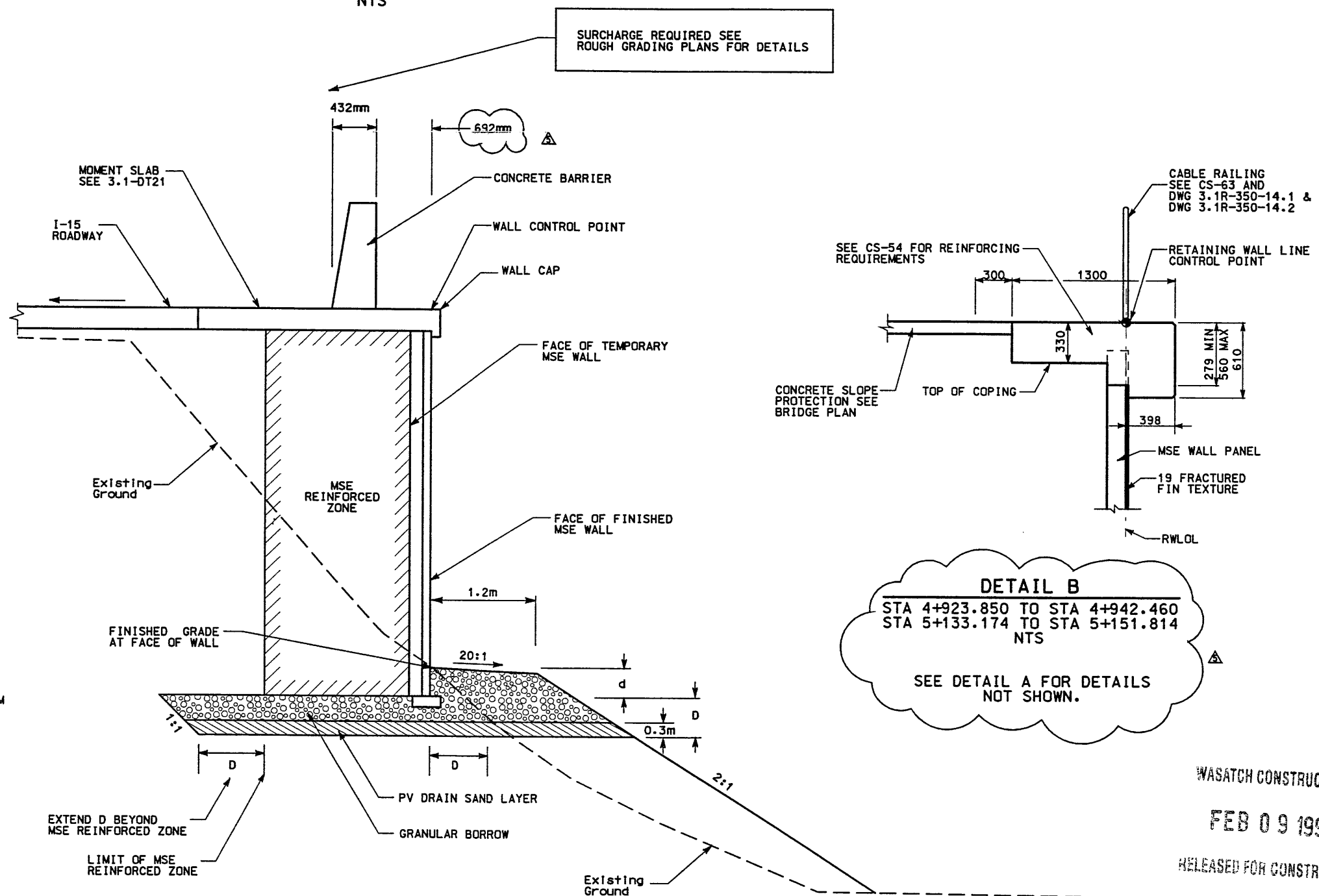

DETAIL B
STA 4+923.850 TO STA 4+942.460
STA 5+133.174 TO STA 5+151.814
NTS
SEE DETAIL A FOR DETAILS
NOT SHOWN.

DETAIL A
STA 4+942.460 TO STA 5+133.174
NTS

EXISTING 1210mm PIPE
TO BE REPLACED

d = EMBEDMENT DEPTH (SEE VSL DETAILS)
D = DESIGN DEPTH OF GRANULAR BORROW
BENEATH WALL (1.0m MINIMUM)
(SEE VSL DETAILS)

- NOTES:
- 1) OVEREXCAVATE EXISTING SOILS TO DEPTH (D) OF 1.0m MINIMUM OR AS SHOWN ON VSL PLANS.
 - 3) SEE CORRIDOR STANDARD SPECIFICATION 221 FOR SPECIAL EXCAVATION REQUIREMENTS WHERE GROUNDWATER IS EXPECTED AT OR ABOVE THE REQUIRED EXCAVATION ELEVATION.
 - 4) SEE CORRIDOR STANDARD SPECIFICATION 210 FOR SPECIAL EXCAVATION AND BACKFILL REQUIREMENTS WHERE SOFT CLAYS OR OTHER SOFT AND/OR WET CONDITIONS ARE ENCOUNTERED.
 - 5) SEE CS-54 FOR COPING DETAILS AT BRIDGE LOCATION.

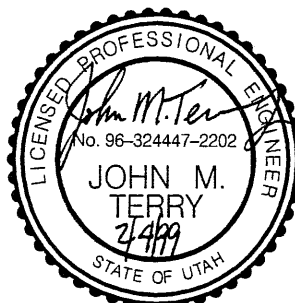

SEALED FOR RELEASE NO. 5 ONLY
(REALIGNMENT OF RETAINING WALL
CONTROL POINT DUE TO FIRST STAGE
SETTLEMENT AND SECOND STAGE
MSE PANEL ALIGNMENT)

APPROVED FOR CONSTRUCTION		DESCRIPTION	
NO.	DATE	NO.	DATE
1	11/03/97	1	11/03/97
2	3/25/98	2	3/25/98
3	9/30/98	3	9/30/98
4	02/02/99	4	02/02/99
REVISE DETAIL AND NOTE 1		98 EARLY G/D/P	
ADDED CABLE RAILING		RELEASE FOR 2ND STAGE CONSTRUCTION	
UTAH DEPARTMENT OF TRANSPORTATION		WBS NO. 3112410	
MK CENTENNIAL		DESIGN DMC 7/29/97 CHECK CJD 9/16/97	
SYVERDRUP/DE LEUW		DRAWN MVM 7/31/97 CHECK CJD 9/16/97	
Bret A. Reynolds		PROJECT DESIGN ENGINEER	
Randle L. Ross		PROJECT MANAGER	
9/16/97		DATE	
3/17/98		DATE	
I-15 CORRIDOR RECONSTRUCTION		SECTION 3.1	
WALL DETAIL R-350-14		PROJECT NUMBER #SP-15-7(135)296	
SALT LAKE COUNTY		DWG. NO. 3.1R-350-14.3	
SHT. 3 OF 12		REF.	

WASATCH CONSTRUCTORS
FEB 09 1999
RELEASED FOR CONSTRUCTION

RFC After Final Approval

RETAINING WALL DETAILS

WALL R-350-14
(2-STAGE MSE WALL)
NTS

SURCHARGE REQUIRED SEE
ROUGH GRADING PLANS FOR DETAILS

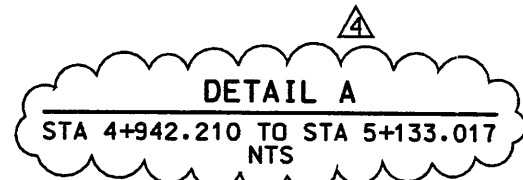
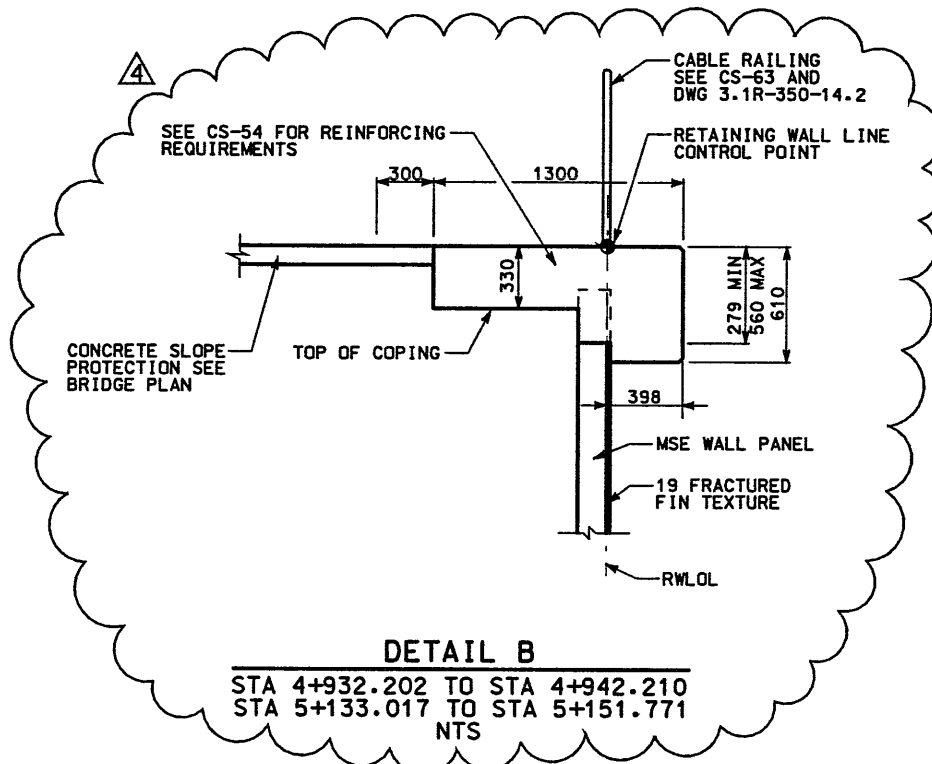
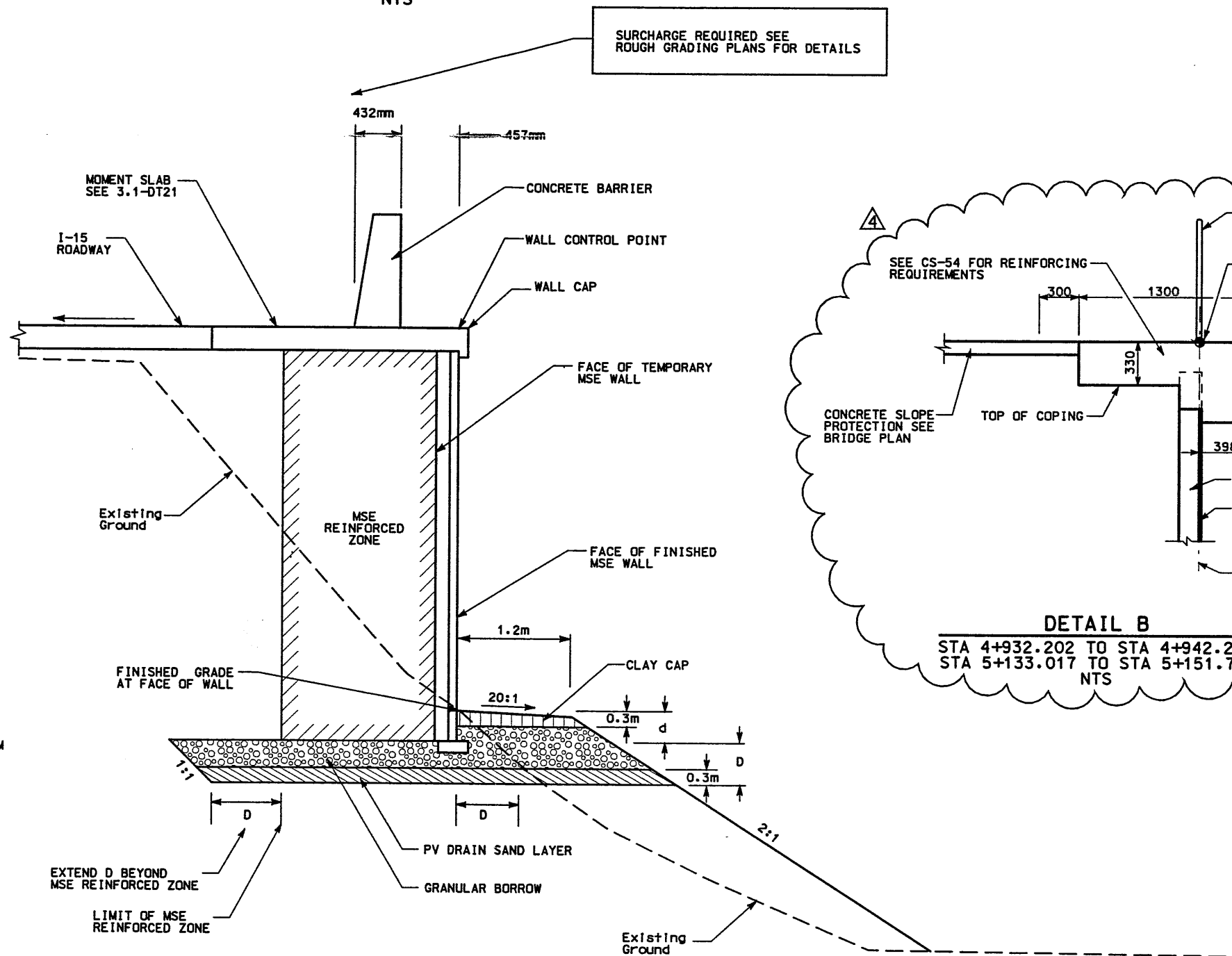

d = EMBEDMENT DEPTH (SEE VSL DETAILS)
D = DESIGN DEPTH OF GRANULAR BORROW
BENEATH WALL (1.0m MINIMUM)
(SEE VSL DETAILS)

- NOTES:
- OVEREXCAVATE EXISTING SOILS TO DEPTH (D) OF 1.0m MINIMUM OR AS SHOWN ON VSL PLANS.
 - CONSTRUCT CLAY CAP WITH LOW PLASTIC SILTY CLAY (0.3m THICK).
 - SEE CORRIDOR STANDARD SPECIFICATION 221 FOR SPECIAL EXCAVATION REQUIREMENTS WHERE GROUNDWATER IS EXPECTED AT OR ABOVE THE REQUIRED EXCAVATION ELEVATION.
 - SEE CORRIDOR STANDARD SPECIFICATION 210 FOR SPECIAL EXCAVATION AND BACKFILL REQUIREMENTS WHERE SOFT CLAYS OR OTHER SOFT AND/OR WET CONDITIONS ARE ENCOUNTERED.
 - SEE CS-54 FOR COPING DETAILS AT BRIDGE LOCATION.

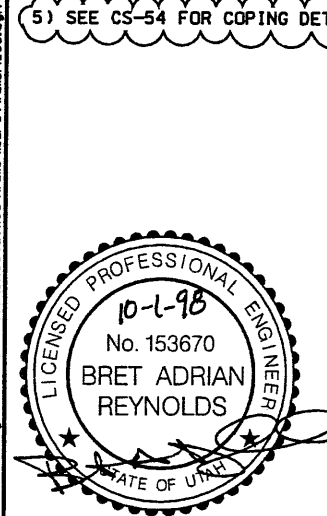

WASATCH CONSTRUCTORS
OCT 07 1998
RELEASED FOR CONSTRUCTION

APPROVED FOR CONSTRUCTION		DESCRIPTION	
NO.	DATE	NO.	DATE
Δ	9/16/97	Δ	9/16/97
Δ	11/03/97	Δ	11/03/97
Δ	3/25/98	Δ	3/25/98
Δ	9/30/98	Δ	9/30/98
ORIGINAL ISSUE		REVISE DETAIL AND NOTE 1	
88 EARLY C/D/P		ADDED CABLE RAILING	
DESIGN DMC 7/29/97		CHECK CJO 9/16/97	
DRAWN MVM 7/31/97		CHECK CJO 9/16/97	
QUANT. JBN 3/17/98		CHECK CJO 3/19/98	
DESIGNER: Bret A. Reynolds		WBS NO. 3112410	
PROJECT DESIGN ENGINEER		PROJECT MANAGER	
APPROVED 9/16/97		DATE	
DATE		DATE	
UTAH DEPARTMENT OF TRANSPORTATION MK CENTENNIAL SVDRUP/DE LEUW			
1-15 CORRIDOR RECONSTRUCTION		SECTION 3.1	
WALL DETAIL R-350-14		#SP-15-7 (135)296	
COUNTY		PROJECT NUMBER	
SALT LAKE			
DWG. NO.			
3.1R-350-14.3			
SHT. 3 OF 12			
REF.			

XREFERENCE (X-UTAH.DWG)
E:\PROJECT\239-0007\13SERIES\13-114\RE-1A
FINAL PLOT 01-25-99

NOTE:
BASED ON POST SETTLEMENT SURVEY OF WIRE FACE LATERAL OUT WARD DISPLACEMENTS RANGED FROM -236mm TO 255mm MEASURED AT THE BASE OF THE WALL.

NOTE:
THE WALL CONNECTIONS ON WALL 350-14 MAY BE ROTATED A MAXIMUM OF 42° VERTICALLY (COL 1 - 10 AND 68 - 75) AND 55° VERTICALLY (COL 11 - 67). SEE DETAIL "SECTION ROTATED" ON VSL STANDARD DRAWING NO. 18 FOR MORE INFORMATION.

APPROVED FOR CONSTRUCTION		
NO.	DATE	DESCRIPTION
△	9-16-97	RELEASE FOR 1ST STAGE CONST. WALL R-350-14 ONLY
△	01-25-99	RELEASE FOR 2ND. STAGE CONSTRUCTION

BRIDGE (F-636N)

BRIDGE (F-637N)

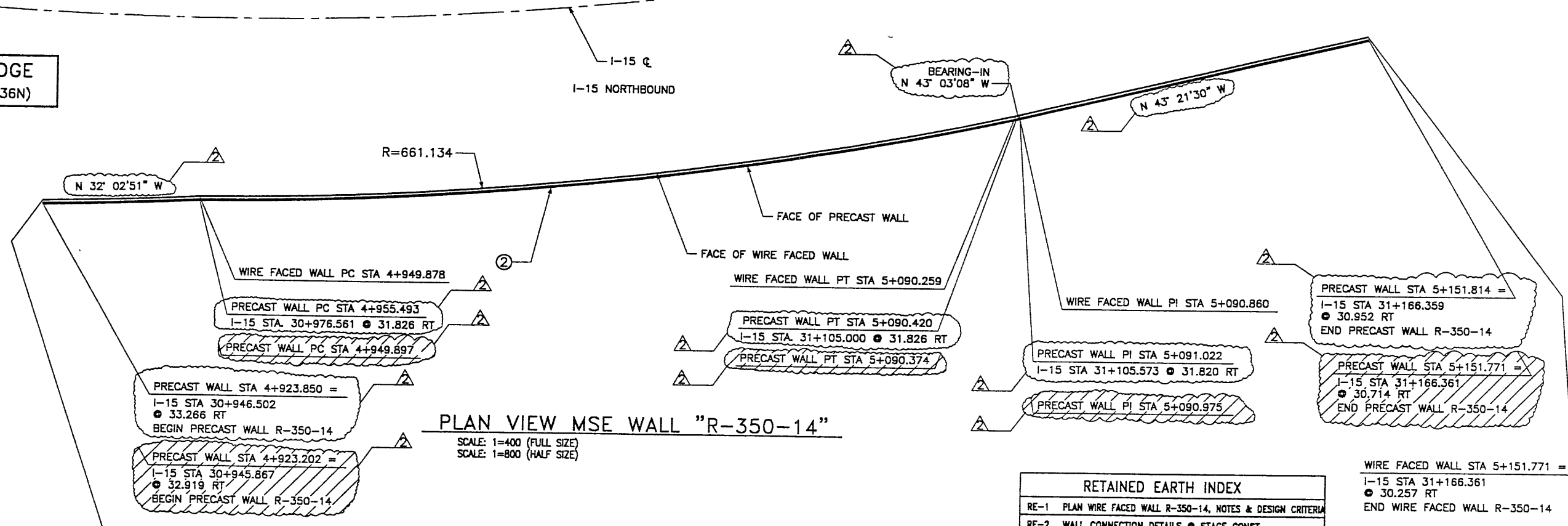

PLAN VIEW MSE WALL "R-350-14"
SCALE: 1=400 (FULL SIZE)
SCALE: 1=800 (HALF SIZE)

CURVE DATA				
No.	RADIUS	LENGTH	TANGENT	△
②	661.826	134.927	67.698	11°40'51"

All Dimensions Are in Meters Unless Noted Otherwise

DESIGN PARAMETERS	
ANGLE OF INTERNAL FRICTION (SELECT)	= 34°
ANGLE OF INTERNAL FRICTION (BASE)	= 30°
ANGLE OF INTERNAL FRICTION (RANDOM)	= 34°
UNIT WEIGHT BACKFILL	= 135 PCF.
TRAFFIC SURCHARGE	= 250 PSF
SEISMIC ACCELERATION COFF.	= 0.27g (TYP)
SEISMIC ACCELERATION COFF.	= 0.68g (AT BRIDGE ABUTMENTS)
DESIGN CRITERIA	
SAFETY FACTOR (OVERTURNING)	= 2.0
SAFETY FACTOR (SLIDING)	= 1.5
SAFETY FACTOR (PULLOUT)	= 1.5
DESIGN LIFE	= 75 YEARS

RETAINED EARTH INDEX	
RE-1	PLAN WIRE FACED WALL R-350-14, NOTES & DESIGN CRITERIA
RE-2	WALL CONNECTION DETAILS @ STAGE CONST.
RE-3	TYPICAL DETAILS
RE-4	TYPICAL CROSS SECTIONS @ WIRE FACED WALL
RE-5	TYPICAL CROSS SECTION
RE-6	WIRE FACED WALL R-350-14
RE-7	WIRE FACED WALL R-350-14
RE-8	WIRE FACED WALL R-350-14
RE-9	WIRE FACED WALL R-350-14
RE-10	PRECAST WALL R-350-14
RE-11	PRECAST WALL R-350-14
RE-12	PRECAST WALL R-350-14
RE-13	PRECAST WALL R-350-14
RE-14	SPECIAL PANEL DETAILS
RE-15	SPECIAL PANEL DETAILS
RE-16	SPECIAL PANEL DETAILS
RE-17	SPECIAL PANEL DETAILS

METRIC

CERTIFIED FOR INTERNAL STABILITY OF RETAINED EARTH™ STRUCTURES ONLY. EXTERNAL STABILITY, INCLUDING BUT NOT LIMITED TO FOUNDATION AND SLOPE STABILITY, IS THE RESPONSIBILITY OF THE OWNER. DESIGN IS BASED ON THE ASSUMPTION THAT THE MATERIAL WITHIN THE RETAINED EARTH™ MASS, METHODS OF CONSTRUCTION, AND QUALITY OF PREFABRICATED MATERIALS CONFORM TO THE MANUFACTURER'S SPECIFICATION.

WIRE FACED WALL STA 5+151.771 =
I-15 STA 31+166.361
● 30.257 RT
END WIRE FACED WALL R-350-14

WASATCH CONSTRUCTORS
FEB 09 1999
RELEASED FOR CONSTRUCTION

RETAINED EARTH™ WALLS	
PLAN VIEW MSE WALL "R-350-14"	
UTAH I-15 INTERCHANGE SALT LAKE COUNTY, UTAH UTAH DEPARTMENT OF TRANSP.	
DWG. NO.	3.1R-350-14.4
JOB NO.	239-0007
SHT. NO.	RE-1

VSL CORPORATION
2840 Plaza Place, Suite 200
Raleigh, NC 27612
Telephone: (919) 781-6272
Fax: (919) 781-6869

ATLANTA, GA / DALLAS, TX / PALMDALE, CA (CORPORATE OFFICE)
MINN. / SAN JOSE, CA / SPRINGFIELD, WA

RFC After Final Approval

FINAL PLAN 09-16-97 E:\PROJECT\239-0007\13SERIES\13-114\PLAN

APPROVED FOR CONSTRUCTION		
NO.	DATE	DESCRIPTION
△	9-16-97	RELEASE FOR 1ST STAGE CONST. WALL R-350-14 ONLY

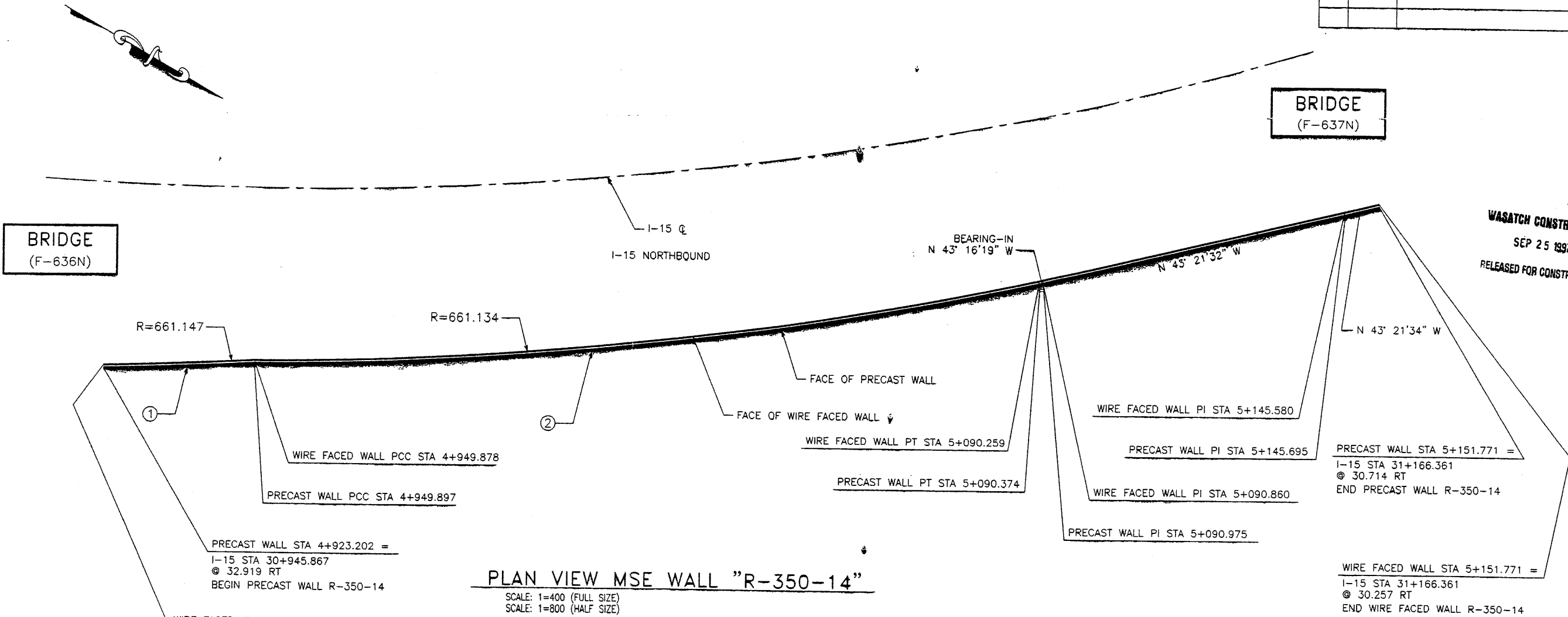

PLAN VIEW MSE WALL "R-350-14"
 SCALE: 1=400 (FULL SIZE)
 SCALE: 1=800 (HALF SIZE)

CURVE DATA				
No.	RADIUS	LENGTH	TANGENT	△
①	661.604	26.694	13.476	2'18"42"
②	661.591	140.478	70.504	12'09"57"

All Dimensions Are In Meters Unless Noted Otherwise

DESIGN PARAMETERS	
ANGLE OF INTERNAL FRICTION (SELECT)	= 34°
ANGLE OF INTERNAL FRICTION (BASE)	= 30°
ANGLE OF INTERNAL FRICTION (RANDOM)	= 34°
UNIT WEIGHT BACKFILL	= 135 PCF.
TRAFFIC SURCHARGE	= 250 PSF
SEISMIC ACCELERATION COFF.	= 0.27g (TYP)
SEISMIC ACCELERATION COFF.	= 0.68g (AT BRIDGE ABUTMENTS)
DESIGN CRITERIA	
SAFETY FACTOR (OVERTURNING)	= 2.0
SAFETY FACTOR (SLIDING)	= 1.5
SAFETY FACTOR (PULLOUT)	= 1.5
DESIGN LIFE	= 75 YEARS

RETAINED EARTH INDEX	
RE-1	PLAN WIRE FACED WALL R-350-14, NOTES & DESIGN CRITERIA
RE-2	WALL CONNECTION DETAILS @ STAGE CONST.
RE-3	TYPICAL DETAILS
RE-4	TYPICAL CROSS SECTIONS @ WIRE FACED WALL
RE-5	TYPICAL CROSS SECTION
RE-6	WIRE FACED WALL R-350-14
RE-7	WIRE FACED WALL R-350-14
RE-8	WIRE FACED WALL R-350-14
RE-9	WIRE FACED WALL R-350-14

SHT 4 OF 12
 METRIC

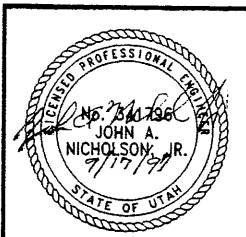

CERTIFIED FOR INTERNAL STABILITY OF RETAINED EARTH™ STRUCTURES ONLY. EXTERNAL STABILITY, INCLUDING BUT NOT LIMITED TO FOUNDATION AND SLOPE STABILITY, IS THE RESPONSIBILITY OF THE OWNER. DESIGN IS BASED ON THE ASSUMPTION THAT THE MATERIAL WITHIN THE RETAINED EARTH™ MASS, METHODS OF CONSTRUCTION, AND QUALITY OF PREFABRICATED MATERIALS CONFORM TO THE MANUFACTURER'S SPECIFICATION.

DES. 09-08-97 MM
 DRN. 09-08-97 DDO
 CHK. 09-08-97 MM
 RETAINED EARTH™

VSL CORPORATION
 2840 Plaza Place, Suite 200
 Raleigh, NC 27612
 Telephone: (919) 781-6772
 Fax: (919) 781-6969

RETAINED EARTH™ WALLS
 PLAN VIEW MSE WALL "R-350-14"
 UTAH I-15 INTERCHANGE
 SALT LAKE COUNTY, UTAH

SCALE: 3.1R-350-14.4
 JOB NO: 239-0007
 RE-1

E:\PROJECT\239-0007\13SERIES\13-114

FINAL F. 09-16-97

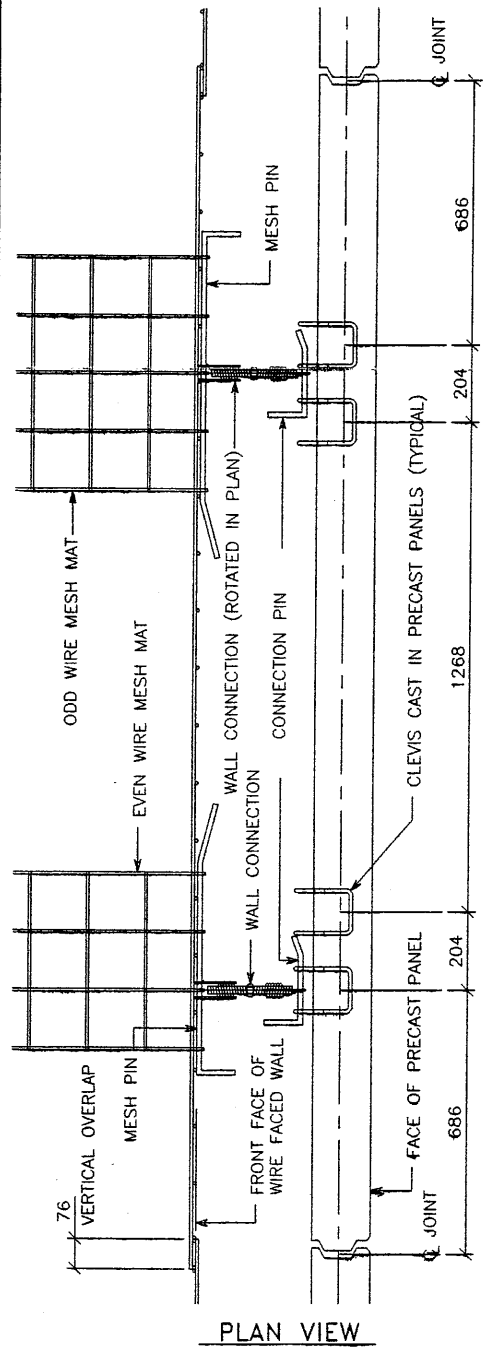

PLAN VIEW

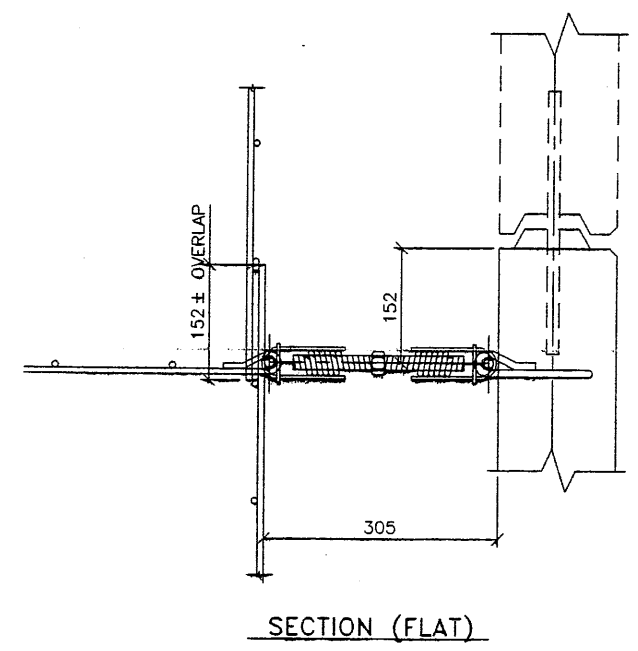

SECTION (FLAT)

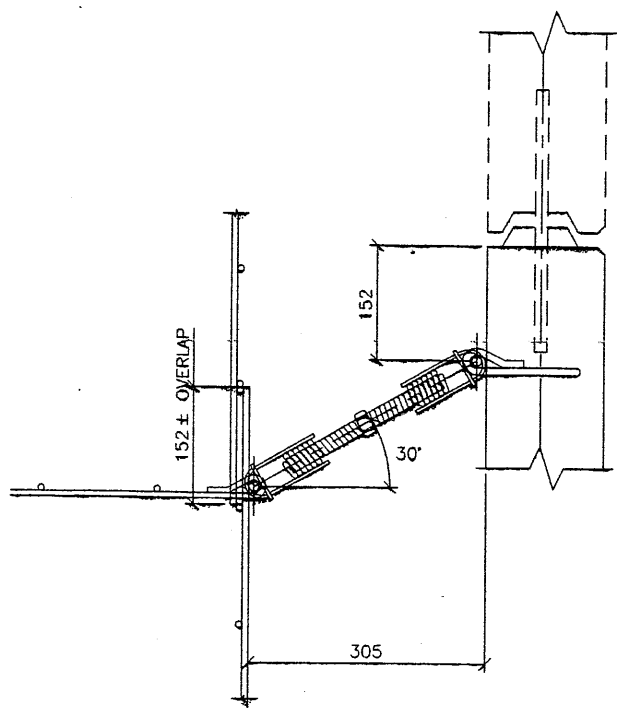

SECTION (ROTATED)

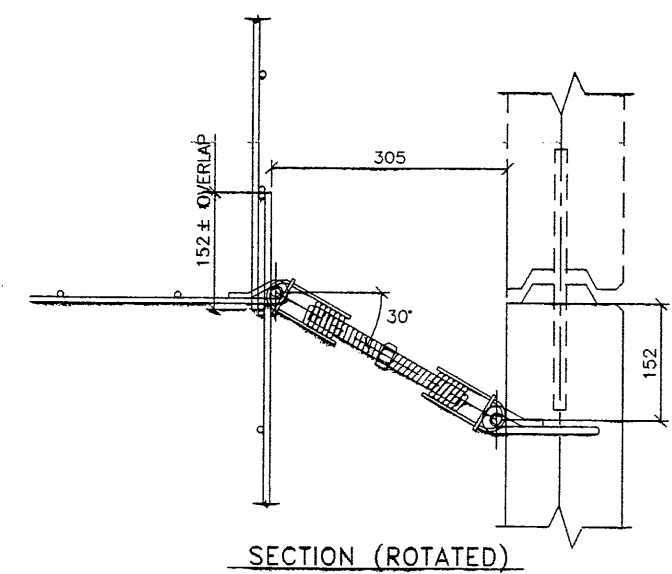

SECTION (ROTATED)

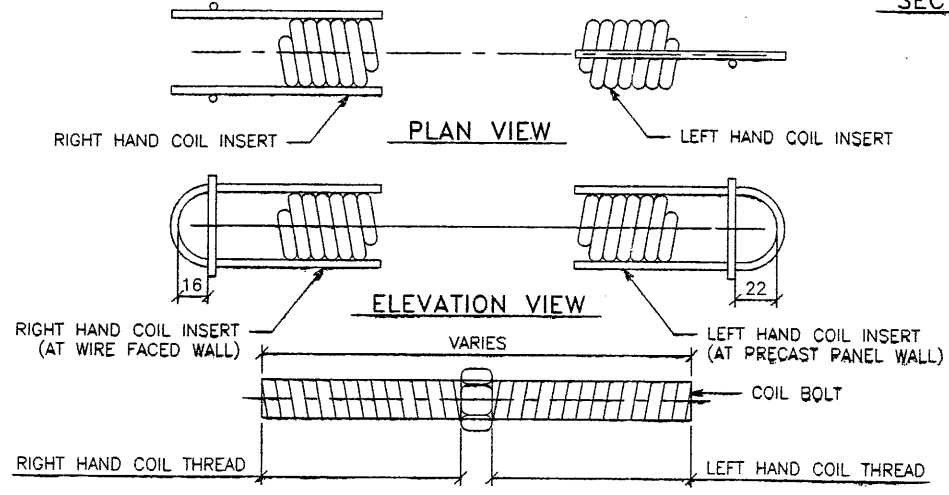

WALL CONNECTION DETAIL

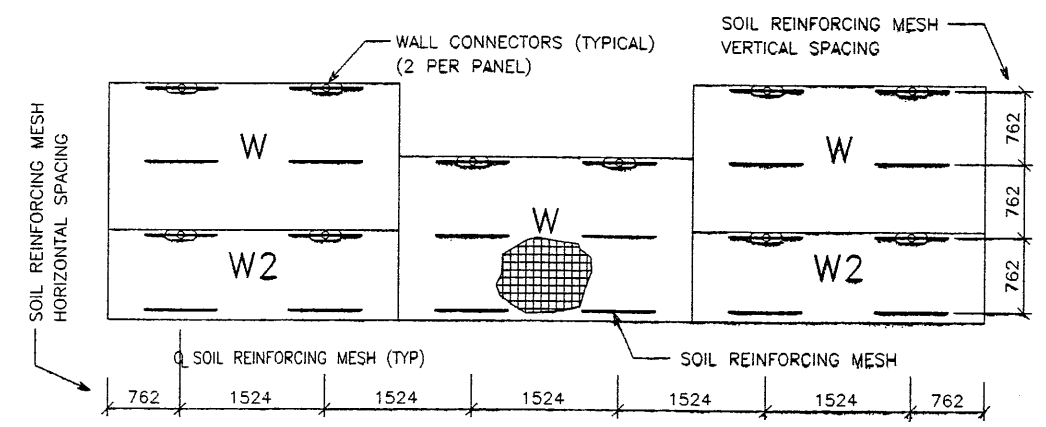

TYPICAL WIRE FACED WALL ELEVATION (WIRE FACE PANELS)

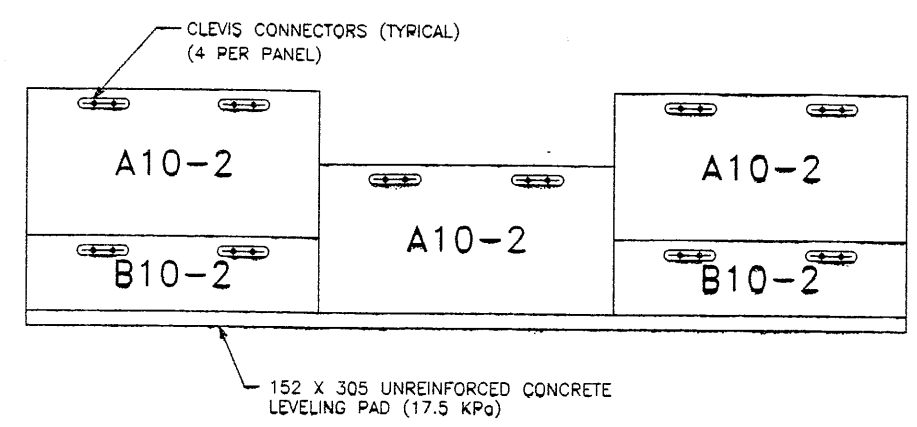

TYPICAL PRECAST WALL ELEVATION (PRECAST PANELS)

APPROVED FOR CONSTRUCTION		
NO.	DATE	DESCRIPTION
9-16-97		RELEASE FOR 1ST STAGE CONST. WALL R-350-14 ONLY

WASATCH CONSTRUCTORS
SEP 25 1997
RELEASED FOR CONSTRUCTION

VSL CORPORATION
2840 Plaza Place, Suite 200
Raleigh, NC 27612
Telephone: (919) 781-6272
Fax: (919) 781-4869



VSL Corporation (VSL) claims a strict proprietary right in its design and construction methods and procedures. Information set forth in this drawing is the property of VSL and is to be used only for the project and site for which it was prepared and is not to be distributed or used for any other project without the written consent of VSL.

SHT 50F12
METRIC

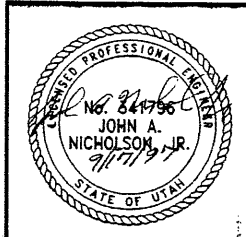

CERTIFIED FOR INTERNAL STABILITY OF RETAINED EARTH™ STRUCTURES ONLY. EXTERNAL STABILITY, INCLUDING BUT NOT LIMITED TO FOUNDATION AND SLOPE STABILITY, IS THE RESPONSIBILITY OF THE OWNER. DESIGN IS BASED ON THE ASSUMPTION THAT THE MATERIAL WITHIN THE RETAINED EARTH™ MASS, METHODS OF CONSTRUCTION, AND QUALITY OF PREFABRICATED MATERIALS CONFORM TO THE MANUFACTURER'S SPECIFICATION.

RETAINED EARTH™ WALLS
WIRE FACED WALL "R-350-14"
WALL CONNECTION DETAILS @ STAGE CONST.
UTAH I-15 INTERCHANGE
SALT LAKE COUNTY, UTAH

SCALE:	3.1R-350-14.5
JOB NO:	239-0007
	RE-2

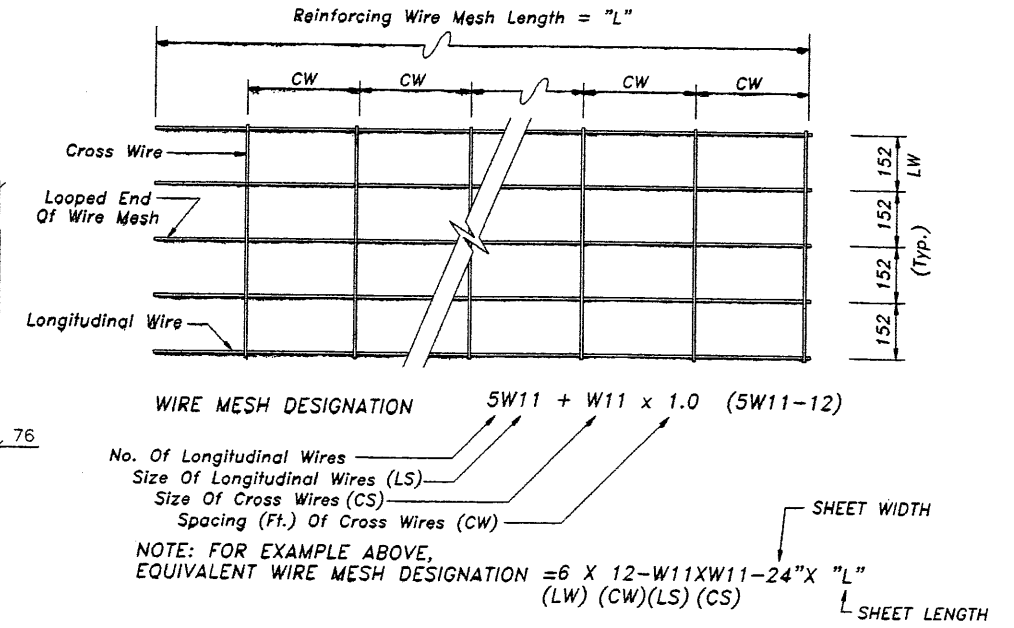
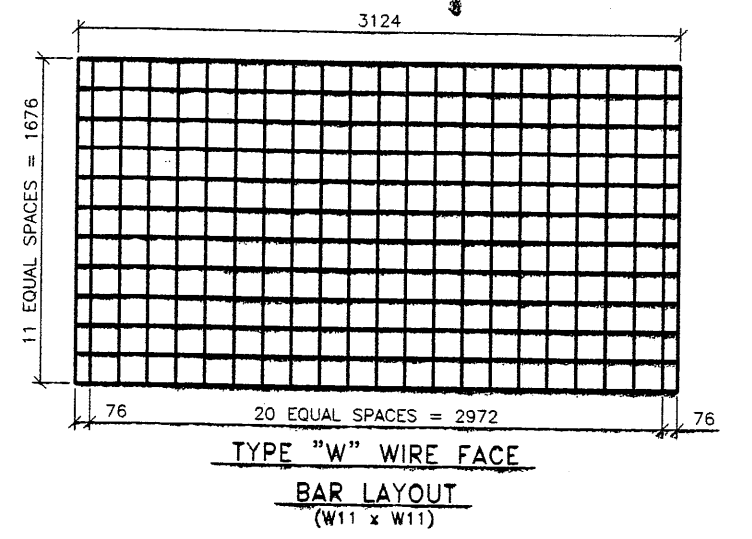
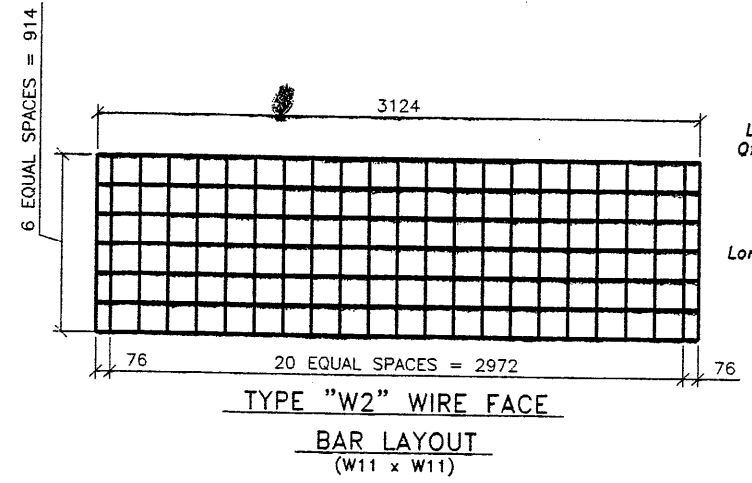
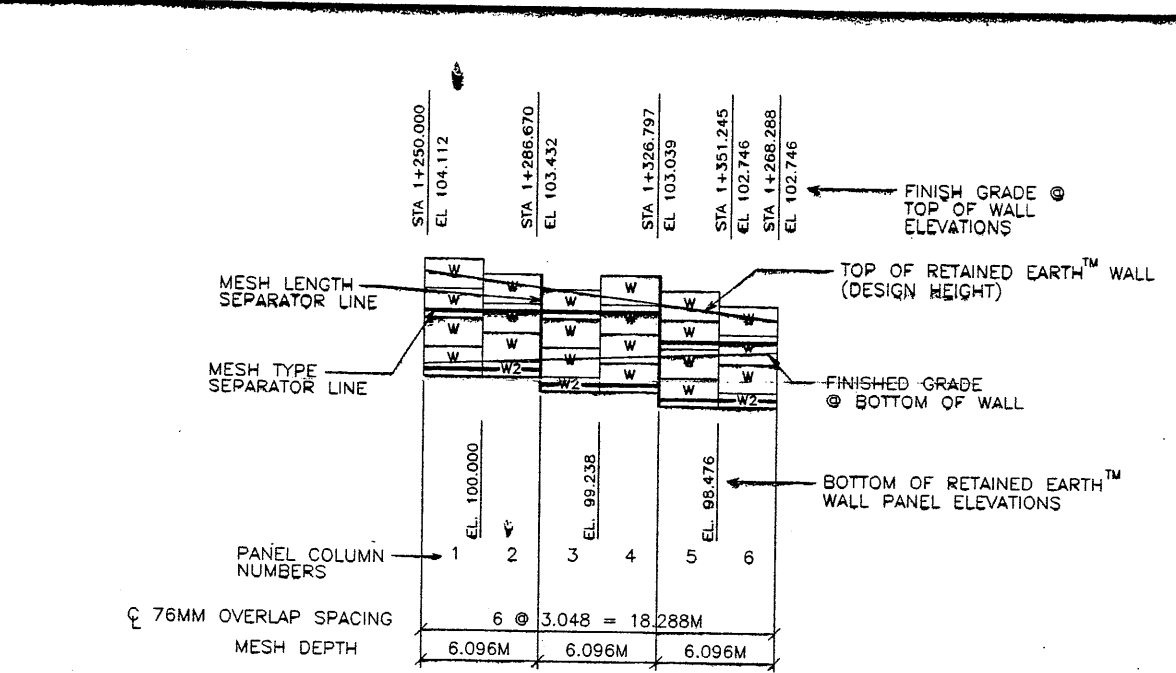
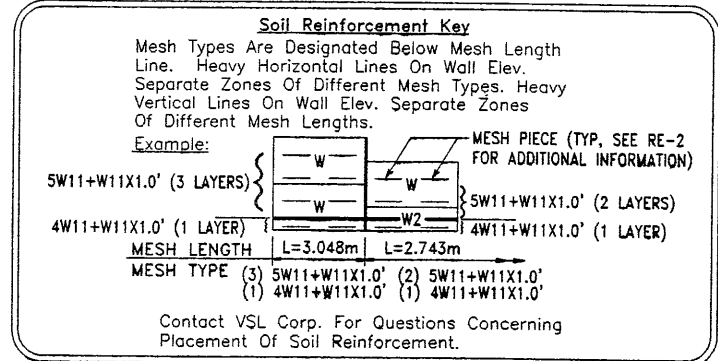
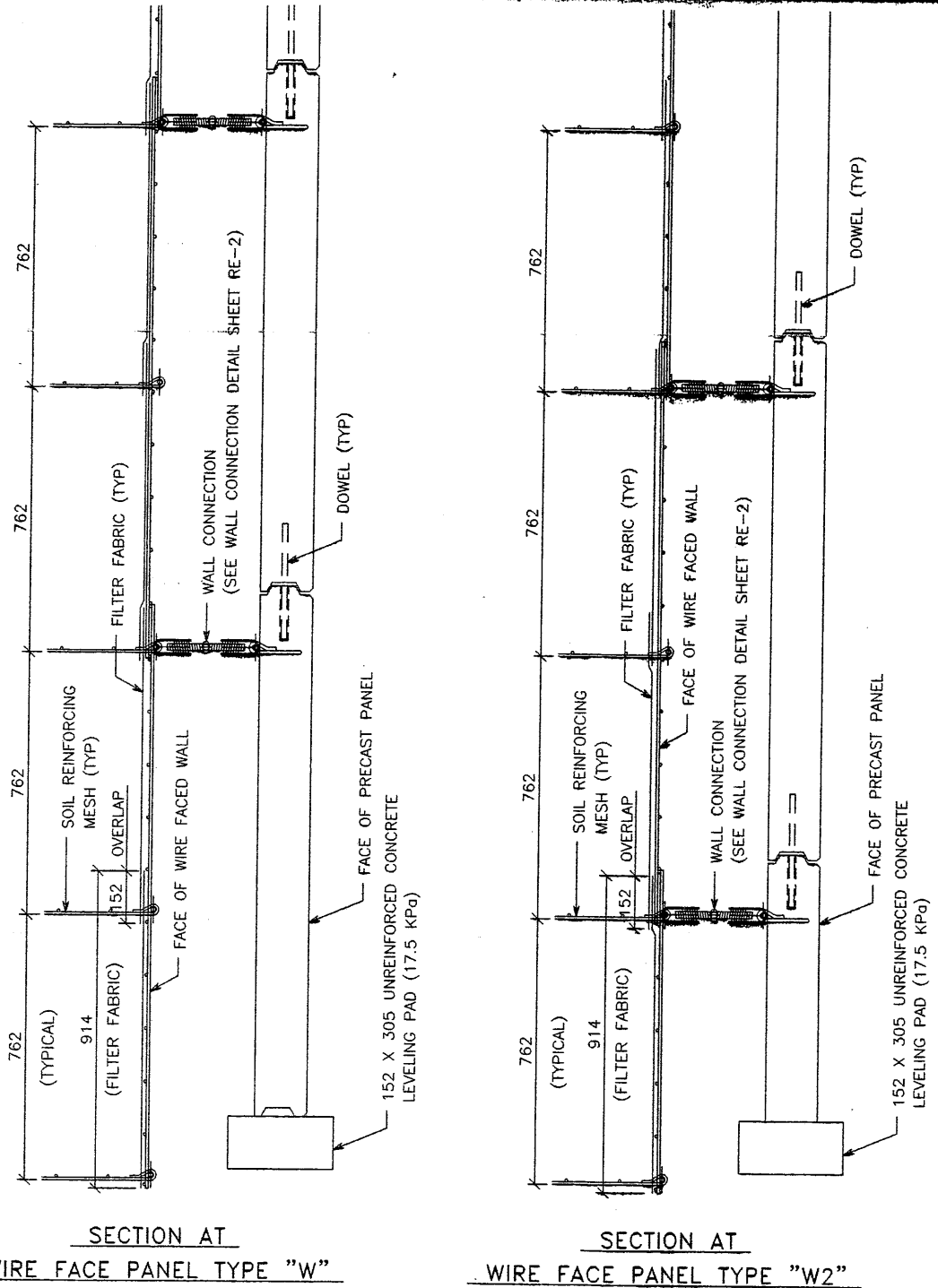

NOTE: W11 (71 sq mm) And W20 (129 sq mm) Steel Wire Material And Welding Of Cross Wires And Loops Shall Conform To ASTM A82 And ASTM 185, Fy = 448 MPa. Mesh Shall Be Galvanized To ASTM A-123 To A Minimum Effective Thickness Of 0.086 mm.

SHT 6 OF 12 METRIC

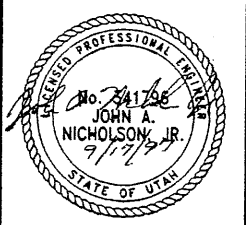

CERTIFIED FOR INTERNAL STABILITY OF RETAINED EARTH™ STRUCTURES ONLY. EXTERNAL STABILITY, INCLUDING BUT NOT LIMITED TO FOUNDATION AND SLOPE STABILITY, IS THE RESPONSIBILITY OF THE OWNER. DESIGN IS BASED ON THE ASSUMPTION THAT THE MATERIAL WITHIN THE RETAINED EARTH™ MASS, METHODS OF CONSTRUCTION, AND QUALITY OF PREFABRICATED MATERIALS CONFORM TO THE MANUFACTURER'S SPECIFICATION.

APPROVED FOR CONSTRUCTION

NO.	DATE	DESCRIPTION
▲	9-16-97	RELEASE FOR 1ST STAGE CONST. WALL R-350-14 ONLY

WARATCH CONSTRUCTORS
 SEP 25 1997
 RELEASED FOR CONSTRUCTION

VSL CORPORATION
 2840 Plaza Place, Suite 200
 Raleigh, NC 27612
 Telephone: (919) 781-6272
 Fax: (919) 781-4669



VSL Corporation (VSL) is a registered provider of continuing education for all states. All courses are approved for CE credit. The use of such information in whole or in part on this project is the responsibility of the user. The user assumes all liability for any errors or omissions in the use of this information.

RETAINED EARTH™ WALLS WIRE FACED WALL "R-350-14" TYPICAL DETAILS
 UTAH I-15 INTERCHANGE SALT LAKE COUNTY, UTAH

SCALE: 3.1R-350-14.E
 JOB NO: 239-0007
 RE-3

E:\PROJECT\239-0007\13SERIES\13-11

09-16-97

FINAL

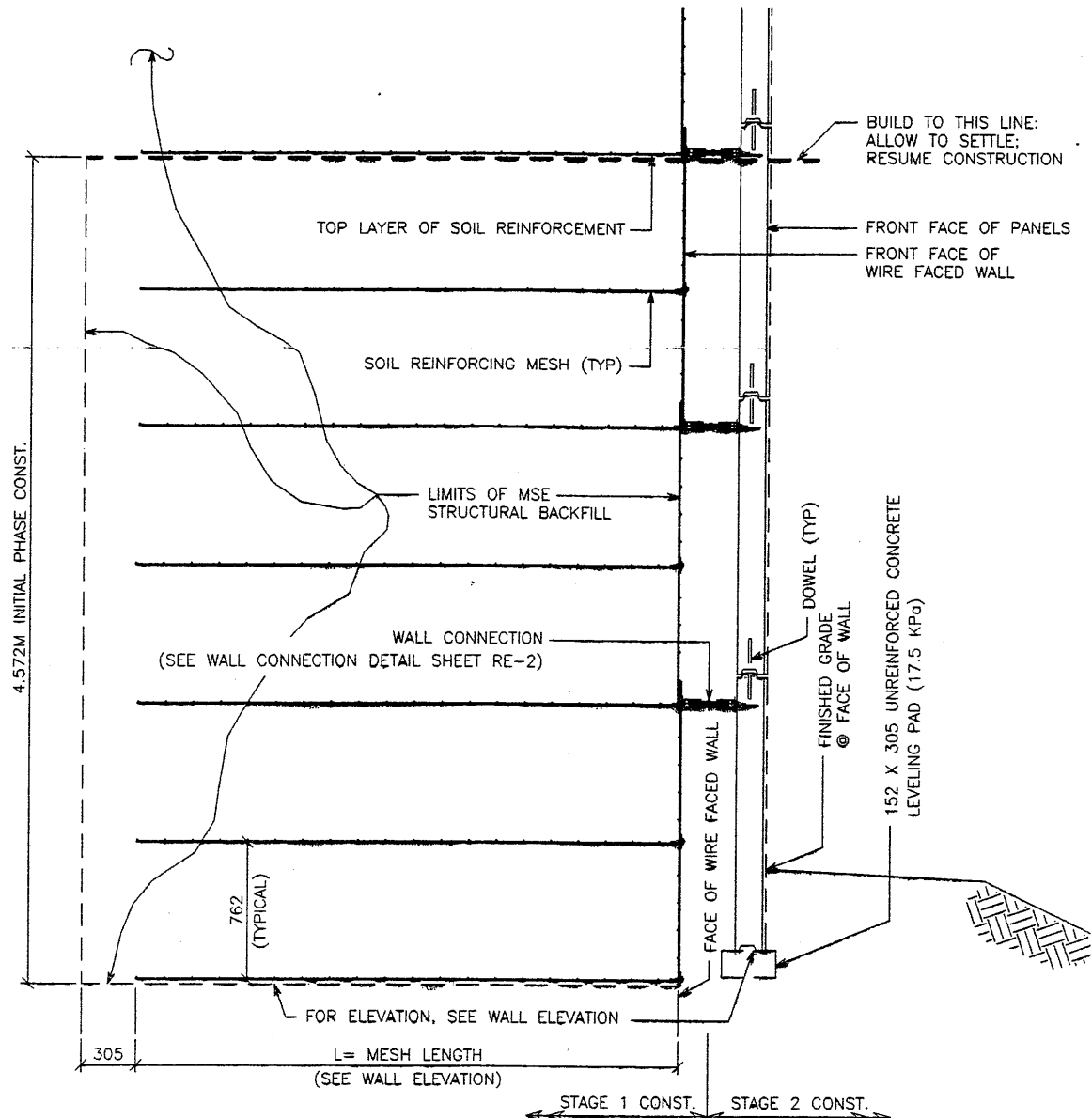

TYPICAL CROSS SECTION AT VERTICAL PHASE CONST.
 SCALE: 1:20 (FULL SIZE)
 SCALE: 1:40 (HALF SIZE)

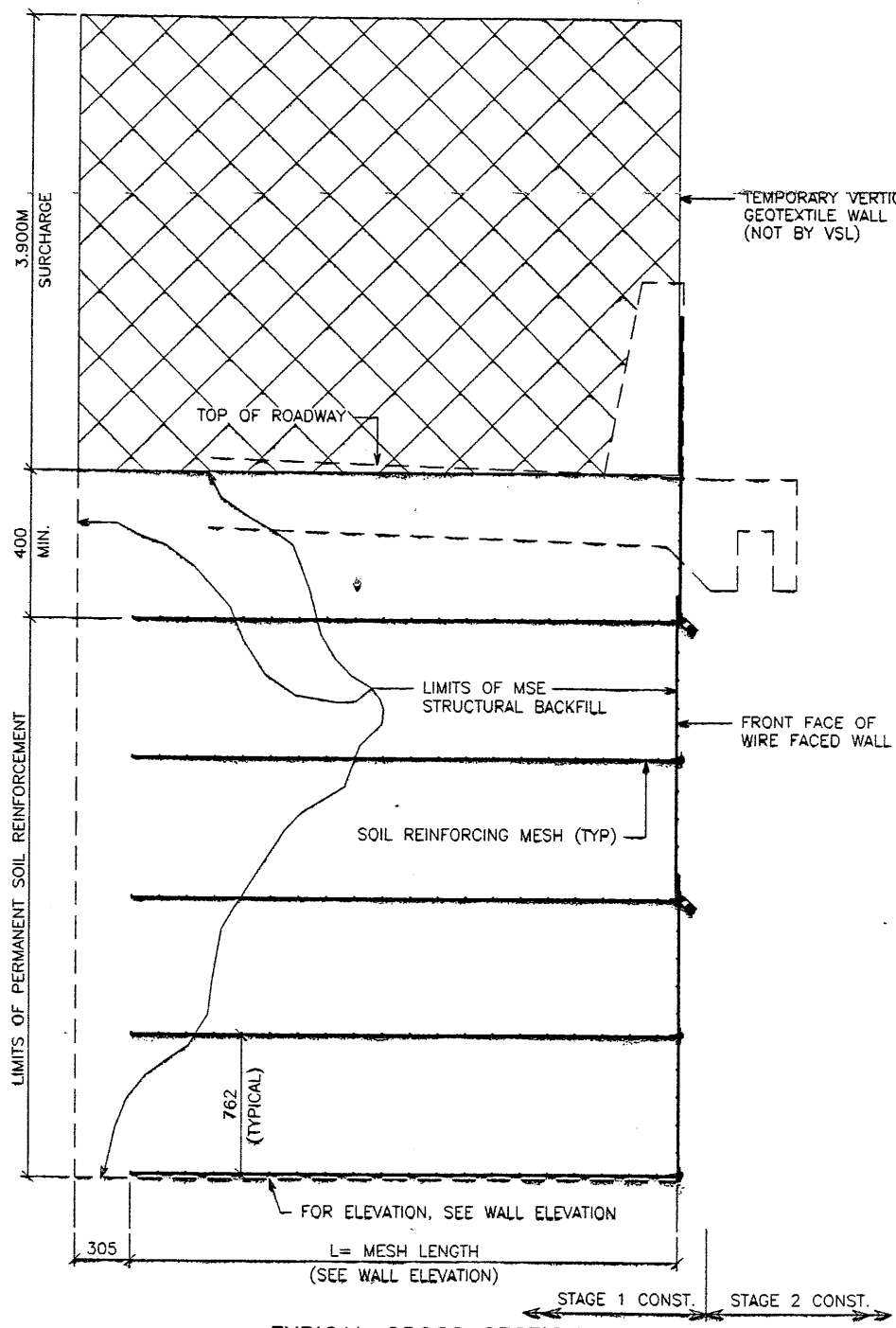

TYPICAL CROSS SECTION AT FINAL PHASE OF WIRE FACE WALL
 SCALE: 1:20 (FULL SIZE)
 SCALE: 1:40 (HALF SIZE)

APPROVED FOR CONSTRUCTION		
NO.	DATE	DESCRIPTION
▲	9-16-97	RELEASE FOR 1ST STAGE CONST. WALL R-350-14 ONLY

WASATCH CONSTRUCTORS
 SEP 25 1997
 RELEASED FOR CONSTRUCTION

NO.	DATE	DESCRIPTION	BY	CHK

VSL CORPORATION
 2840 Photo Place, Suite 200
 Raleigh, NC 27612
 Telephone: (919) 781-6272
 Fax: (919) 781-6889

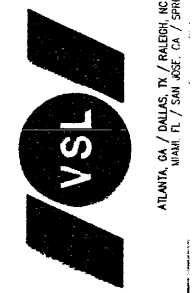

VSL Corporation (VSL) does a strict proprietary design and construction. VSL's design and construction are based on the information provided to VSL by the client. VSL is not responsible for any errors or omissions in the design or construction of the project. VSL is not responsible for any damage to property or persons resulting from the use of the design or construction. VSL is not responsible for any claims, damages, or liabilities arising from the use of the design or construction. VSL is not responsible for any claims, damages, or liabilities arising from the use of the design or construction.

RETAINED EARTH™ WALLS
WIRE FACED WALL "R-350-14"
TYPICAL SECTIONS @ WIRE FACED WALL
UTAH I-15 INTERCHANGE
SALT LAKE COUNTY, UTAH
UTAH DEPARTMENT OF TRANSP.

SHT 70F12
 METRIC

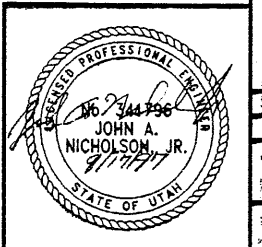

CERTIFIED FOR INTERNAL STABILITY OF RETAINED EARTH™ STRUCTURES ONLY. EXTERNAL STABILITY, INCLUDING BUT NOT LIMITED TO FOUNDATION AND SLOPE STABILITY, IS THE RESPONSIBILITY OF THE OWNER. DESIGN IS BASED ON THE ASSUMPTION THAT THE MATERIAL WITHIN THE RETAINED EARTH™ MASS, METHODS OF CONSTRUCTION, AND QUALITY OF PREFABRICATED MATERIALS CONFORM TO THE MANUFACTURER'S SPECIFICATION.

SCALE:	3.1R-350-14.7
JOB NO:	239-0007
	RE-4

E:\PROJECT\239-0007\13SERIES\13-114

19-16-97

FINAL F

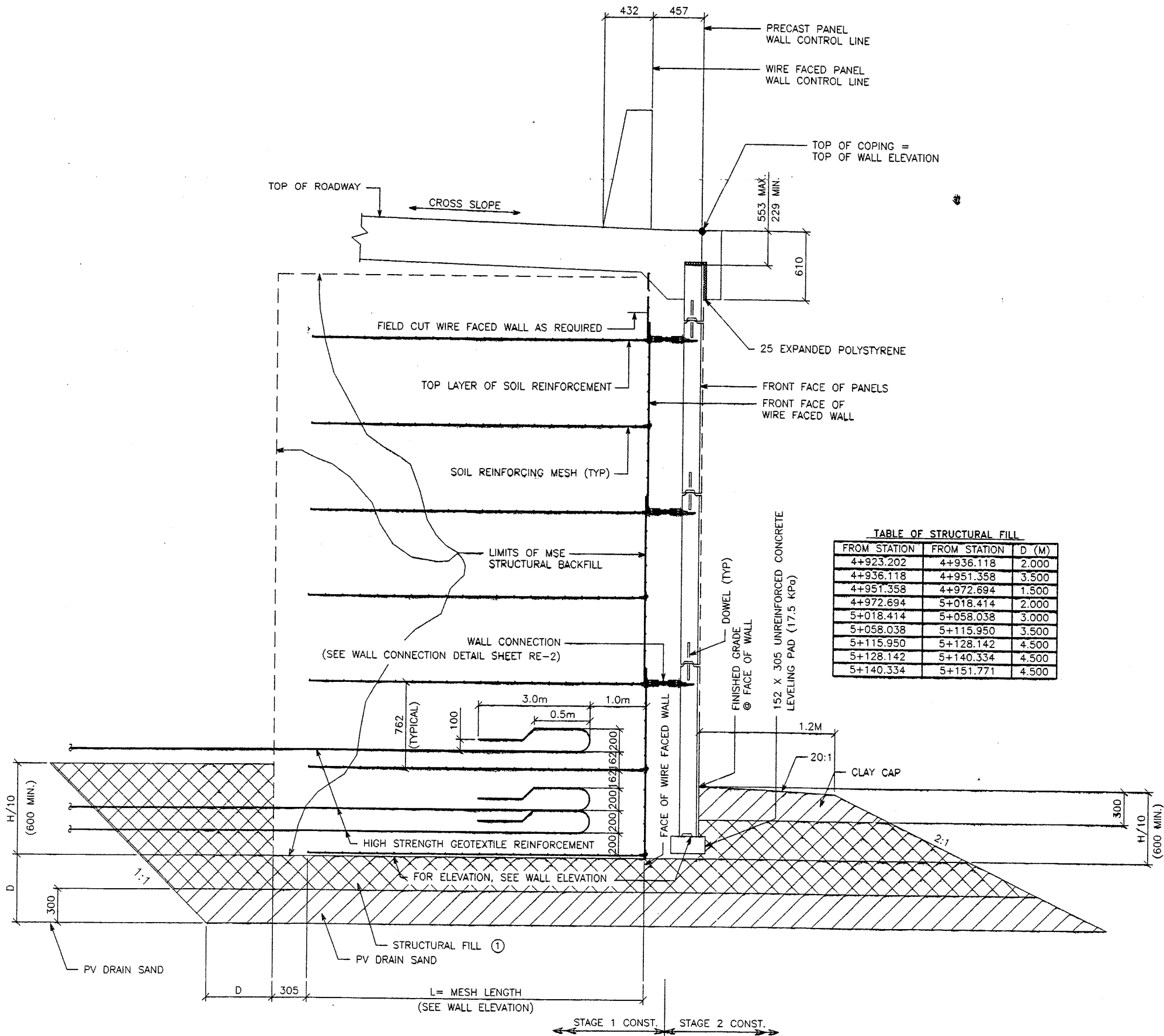

TABLE OF STRUCTURAL FILL

FROM STATION	FROM STATION	D (M)
4+923.202	4+936.118	2.000
4+936.118	4+951.358	3.500
4+951.358	4+972.694	1.500
4+972.694	5+018.414	2.000
5+018.414	5+058.038	3.000
5+058.038	5+115.950	3.500
5+115.950	5+128.142	4.500
5+128.142	5+140.334	4.500
5+140.334	5+151.771	4.500

TYPICAL CROSS SECTION
 SCALE: 1:20 (FULL SIZE)
 SCALE: 1:40 (HALF SIZE)

CERTIFIED FOR INTERNAL STABILITY OF RETAINED EARTH™ STRUCTURES ONLY. EXTERNAL STABILITY, INCLUDING BUT NOT LIMITED TO FOUNDATION AND SLOPE STABILITY, IS THE RESPONSIBILITY OF THE OWNER. DESIGN IS BASED ON THE ASSUMPTION THAT THE MATERIAL WITHIN THE RETAINED EARTH™ MASS, METHODS OF CONSTRUCTION, AND QUALITY OF PREFABRICATED MATERIALS CONFORM TO THE MANUFACTURER'S SPECIFICATION.

APPROVED FOR CONSTRUCTION

NO.	DATE	DESCRIPTION
△	9-16-97	RELEASE FOR 1ST STAGE CONST. WALL R-350-14 ONLY

WASATCH CONSTRUCTORS
 SEP 25 1997
 RELEASED FOR CONSTRUCTION

DES.	MM	NO.	DATE
09-08-97	MM		
09-08-97	DDO		
09-08-97	MM		

VSL CORPORATION
 2840 Plaza Place, Suite 200
 Raleigh, NC 27612
 Telephone: (919) 781-6772
 Fax: (919) 781-6869

ATLANTA, GA / DALLAS, TX / PALMDALE, CA (CORPORATE OFFICE)
 MIAMI, FL / SAN JOSE, CA / SPRINGFIELD, VA

VSL Corporation (VSL) does a strict proprietary design and calculation. Information is for reference only. No liability is assumed for any reproduction or use of this information without the written consent of VSL. VSL reserves the right to change any liability without notice.

RETAINED EARTH™ WALLS
 WIRE FACED WALL "R-350-14"
 TYPICAL CROSS SECTION
 UTAH I-15 INTERCHANGE
 SALT LAKE COUNTY, UTAH
 UTAH DEPARTMENT OF TRANSP.

SHT 80612
 METRIC

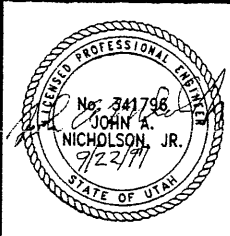

SCALE:	3.1R-350-14.8
JOB NO:	239-0007
REVISION:	RE-5

E:\PROJECT\239-0007\1SERIES\13-114\W13-114

FINAL PLC -29-97

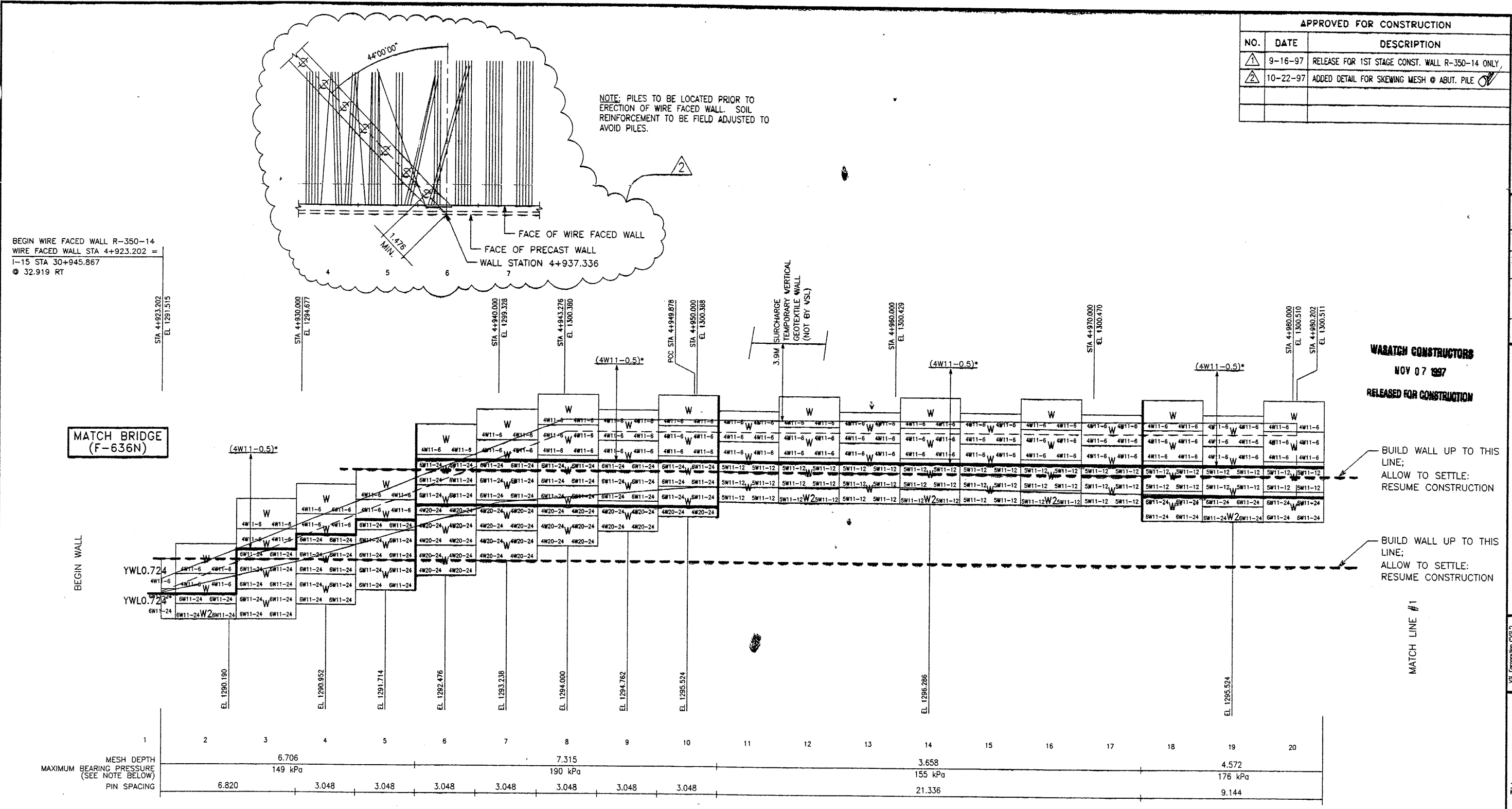

APPROVED FOR CONSTRUCTION		
NO.	DATE	DESCRIPTION
1	9-16-97	RELEASE FOR 1ST STAGE CONST. WALL R-350-14 ONLY
2	10-22-97	ADDED DETAIL FOR SKEWING MESH @ ABUT. PILE

WASATCH CONSTRUCTORS
NOV 07 1997
RELEASED FOR CONSTRUCTION

VSL CORPORATION
2840 Plaza Place, Suite 200
Raleigh, NC 27612
Telephone: (919) 781-6272
Fax: (919) 781-0969

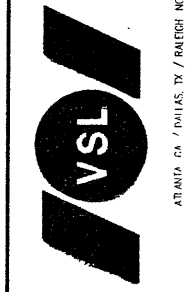

VSL Corporation (VSL) does a strict proprietary design and construction of retaining walls and structures. VSL's design and construction methods are based on extensive research and field experience. VSL's design and construction methods are based on extensive research and field experience. VSL's design and construction methods are based on extensive research and field experience.

RETAINED EARTH™ WALLS
WALL "R-350-14" - 1ST STAGE: WIRE FACED WALL
UTAH I-15 INTERCHANGE
SALT LAKE COUNTY, UTAH
UTAH DEPARTMENT OF TRANSPORTATION

SCALE:	3.1R-350-14.9
JOB NO.:	239-0007
REVISION:	RE-6

BEGIN WIRE FACED WALL R-350-14
WIRE FACED WALL STA 4+923.202 =
1-15 STA 30+945.867
● 32.919 RT

NOTE: PILES TO BE LOCATED PRIOR TO ERECTION OF WIRE FACED WALL. SOIL REINFORCEMENT TO BE FIELD ADJUSTED TO AVOID PILES.

BUILD WALL UP TO THIS LINE;
ALLOW TO SETTLE;
RESUME CONSTRUCTION

BUILD WALL UP TO THIS LINE;
ALLOW TO SETTLE;
RESUME CONSTRUCTION

RETAINING WALL "R-350-14" - 1ST STAGE: WIRE FACED WALL
(FRONT FACE SHOWN)
(TOTAL SURFACE AREA OF FACING = 1,528.61 SM)
SCALE 1:100 (FULL SIZE)
SCALE 1:200 (HALF SIZE)

APPROVER NOTE:
MAXIMUM FINAL UNFACTORED BEARING PRESSURES ARE INDICATED BELOW "MESH DEPTH LINE". REVIEWER TO VERIFY MAXIMUM BEARING CAPACITY OF FOUNDATION.

* INDICATES SOIL REINFORCING TYPE MESH TO BE USED ON ADDITIONAL WIRE WALL FACING ADDED AFTER SETTLEMENT.

CERTIFIED FOR INTERNAL STABILITY OF RETAINED EARTH™ STRUCTURES ONLY. EXTERNAL STABILITY, INCLUDING BUT NOT LIMITED TO FOUNDATION AND SLOPE STABILITY, IS THE RESPONSIBILITY OF THE OWNER. DESIGN IS BASED ON THE ASSUMPTION THAT THE MATERIAL WITHIN THE RETAINED EARTH™ MASS, METHODS OF CONSTRUCTION, AND QUALITY OF PREFABRICATED MATERIALS CONFORM TO THE MANUFACTURER'S SPECIFICATION.

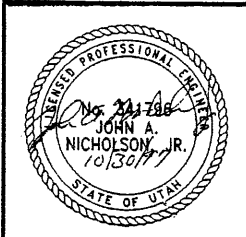

APPROVED FOR CONSTRUCTION		
NO.	DATE	DESCRIPTION
△	9-16-97	RELEASE FOR 1ST STAGE CONST. WALL R-350-14 ONLY

WASATCH CONSTRUCTORS
 SEP 25 1997
 RELEASED FOR CONSTRUCTION

DES.	09-08-97	MM
DRN.	09-08-97	DDO
CHK.	09-08-97	MM

RETAINED EARTH™



VSL CORPORATION (VSL)
 2840 Plaza Place, Suite 300
 Raleigh, NC 27612
 Telephone: (919) 781-8272
 Fax: (919) 781-4989

RETAINED EARTH™ WALLS
 WALL "R-350-14" - 1ST STAGE: WIRE FACED WALL
 UTAH I-15 INTERCHANGE
 SALT LAKE COUNTY, UTAH
 UTAH DEPARTMENT OF TRANSPORTATION

SCALE:	3.1R-350-14.10
JOB NO.:	239-0007
	RE-7

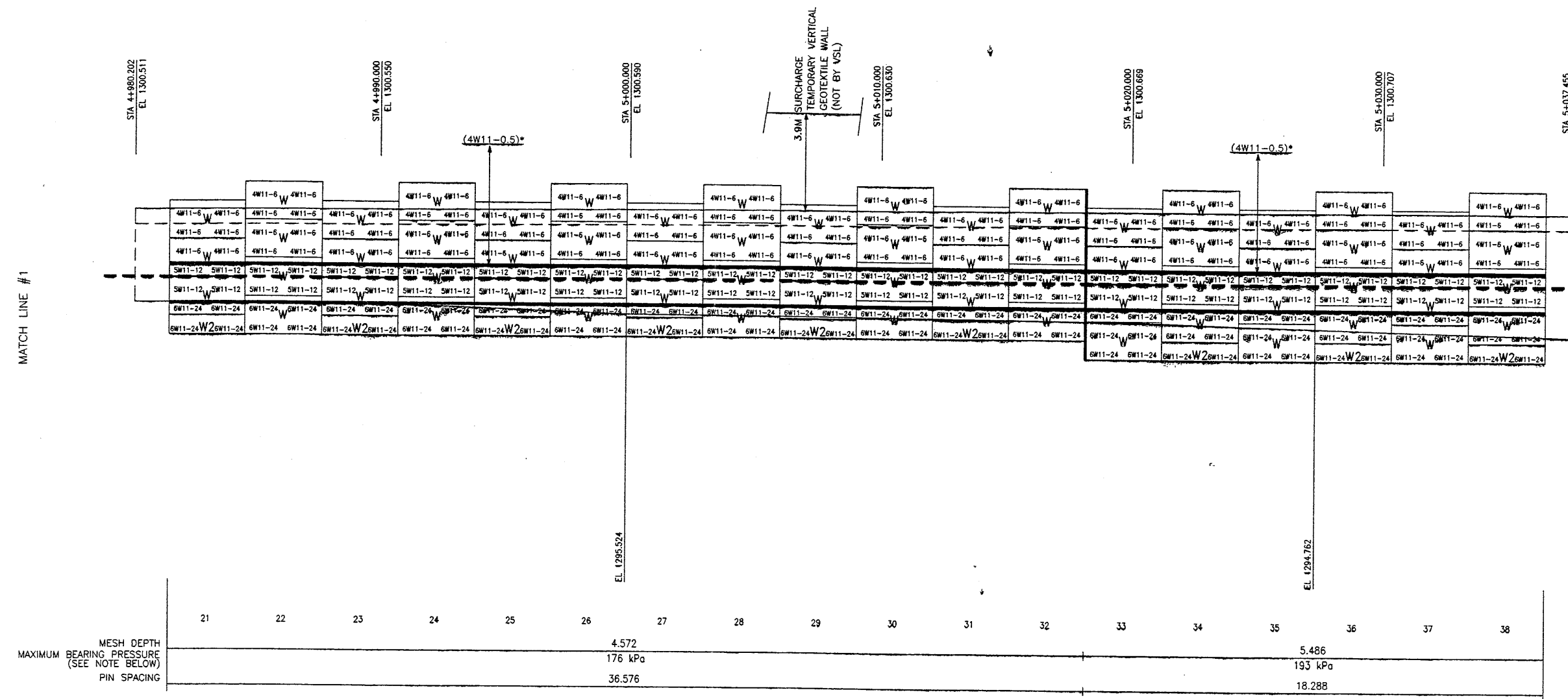

APPROVER NOTE:
 MAXIMUM FINAL UNFACTORED BEARING PRESSURES ARE INDICATED BELOW "MESH DEPTH LINE". REVIEWER TO VERIFY MAXIMUM BEARING CAPACITY OF FOUNDATION.

* INDICATES SOIL REINFORCING TYPE MESH TO BE USED ON ADDITIONAL WIRE WALL FACING ADDED AFTER SETTLEMENT.

SCALE 1:100 (FULL SIZE)
 SCALE 1:200 (HALF SIZE)

SH2 10 OF 12
 METRIC

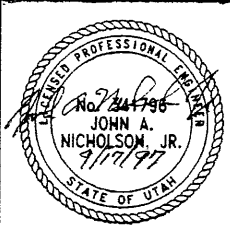

CERTIFIED FOR INTERNAL STABILITY OF RETAINED EARTH™ STRUCTURES ONLY. EXTERNAL STABILITY, INCLUDING BUT NOT LIMITED TO FOUNDATION AND SLOPE STABILITY, IS THE RESPONSIBILITY OF THE OWNER. DESIGN IS BASED ON THE ASSUMPTION THAT THE MATERIAL WITHIN THE RETAINED EARTH™ MASS, METHODS OF CONSTRUCTION, AND QUALITY OF PREFABRICATED MATERIALS CONFORM TO THE MANUFACTURER'S SPECIFICATION.

APPROVED FOR CONSTRUCTION		
NO.	DATE	DESCRIPTION
▲	9-16-97	RELEASE FOR 1ST STAGE CONST. WALL R-350-14 ONLY

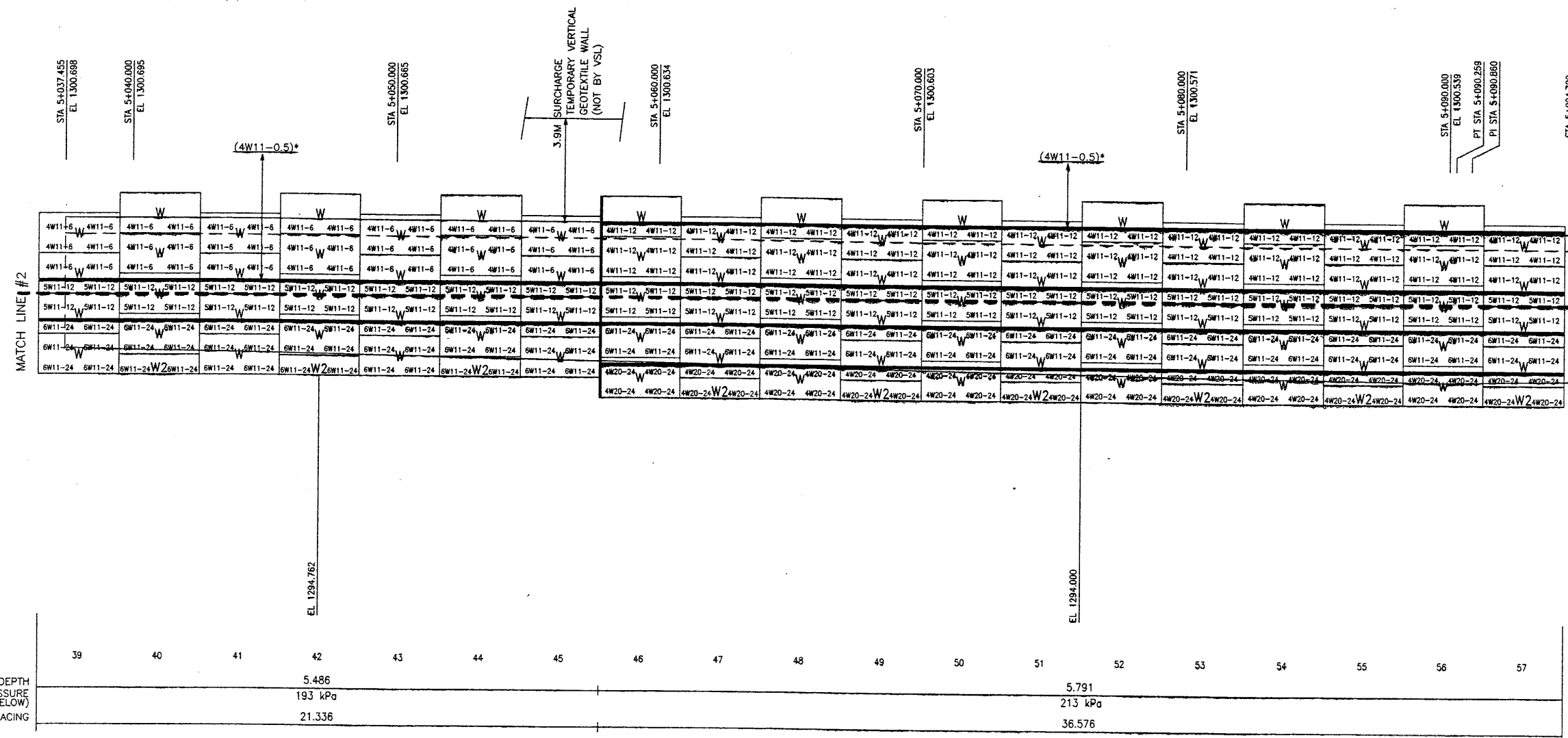

WASATCH CONSTRUCTORS
SEP 25 1997
RELEASED FOR CONSTRUCTION

BUILD WALL UP TO THIS LINE;
 ALLOW TO SETTLE;
 RESUME CONSTRUCTION

MATCH LINE #3

MESH DEPTH
 MAXIMUM BEARING PRESSURE (SEE NOTE BELOW)
 PIN SPACING

39	40	41	42	43	44	45	46	47	48	49	50	51	52	53	54	55	56	57
5.486																		
193 kPa																		
21.336																		
5.791												213 kPa						
36.576												36.576						

SCALE 1:100 (FULL SIZE)
 SCALE 1:200 (HALF SIZE)

APPROVER NOTE:
 MAXIMUM FINAL UNFACTORED BEARING PRESSURES ARE INDICATED BELOW "MESH DEPTH LINE" REVIEWER TO VERIFY MAXIMUM BEARING CAPACITY OF FOUNDATION.

* INDICATES SOIL REINFORCING TYPE MESH TO BE USED ON ADDITIONAL WIRE WALL FACING ADDED AFTER SETTLEMENT.

CERTIFIED FOR INTERNAL STABILITY OF RETAINED EARTH™ STRUCTURES ONLY. EXTERNAL STABILITY, INCLUDING BUT NOT LIMITED TO FOUNDATION AND SLOPE STABILITY, IS THE RESPONSIBILITY OF THE OWNER. DESIGN IS BASED ON THE ASSUMPTION THAT THE MATERIAL WITHIN THE RETAINED EARTH™ MASS, METHODS OF CONSTRUCTION, AND QUALITY OF PREFABRICATED MATERIALS CONFORM TO THE MANUFACTURER'S SPECIFICATION.

SHT 11 OF 12
 METRIC

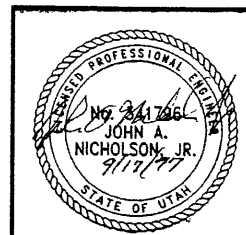

REVISION

NO.	DATE	DESCRIPTION

DES. 09-08-97 MM
 DRN. 09-08-97 DDD
 CHK. 09-08-97 MM

RETAINED EARTH™

VSL CORPORATION
 2840 Plaza Place, Suite 200
 Raleigh, NC 27602
 Telephone: (919) 761-6272
 Fax: (919) 761-6869

ATLANTA, GA / DALLAS, TX / FALCON, NC (CORPORATE OFFICE)
 MIAMI, FL / SAN JOSE, CA / SPRINGFIELD, VA

RETAINED EARTH™ WALLS
 WALL "R-350-14" - 1ST STAGE: WIRE FACED WALL
 UTAH I-15 INTERCHANGE
 SALT LAKE COUNTY, UTAH
 UTAH DEPARTMENT OF TRANSP.

SCALE:
 3.1R-350-14.11
 JOB NO:
 239-0007
 RE-8

E:\PROJECT\239-0007\13SERIES\13-114\W13-114
FINAL PLG, 10-29-97

APPROVED FOR CONSTRUCTION		
NO.	DATE	DESCRIPTION
9-16-97		RELEASE FOR 1ST STAGE CONST. WALL R-350-14 ONLY
10-22-97		ADDED DETAIL FOR SKEWING MESH @ ABUT. PILE

NOTE: PILES TO BE LOCATED PRIOR TO ERECTION OF WIRE FACED WALL. SOIL REINFORCEMENT TO BE FIELD ADJUSTED TO AVOID PILES.

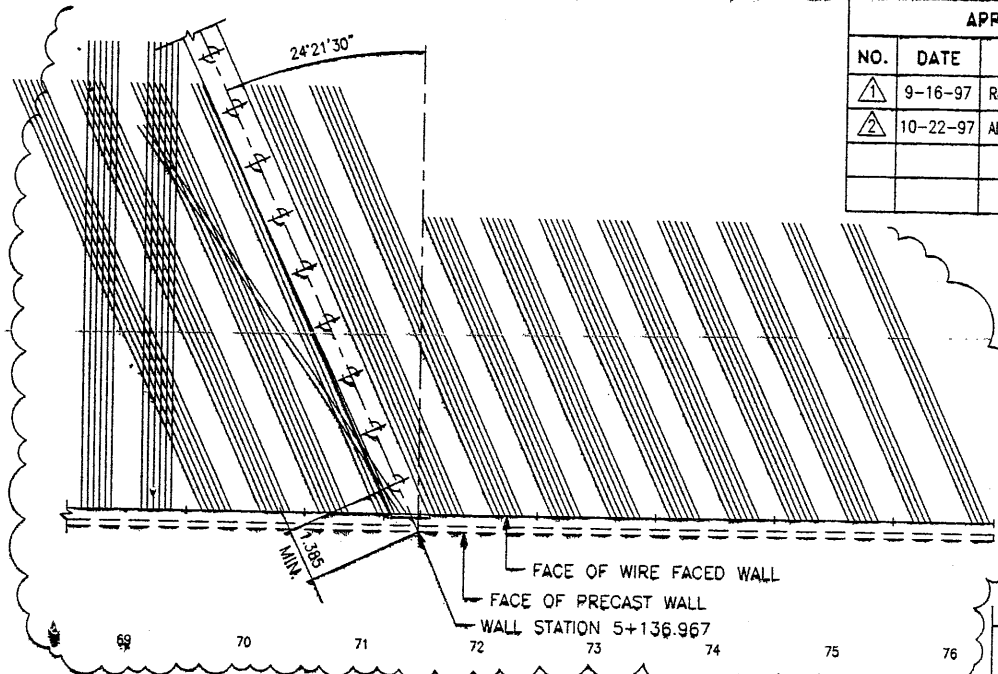

END WIRE FACED WALL R-350-14
WIRE FACED WALL STA 5+151.771 =
1-15 STA 31+166.361
@ 30.714 RT

WATCH CONSTRUCTORS
NOV 07 1997
RELEASED FOR CONSTRUCTION

MATCH BRIDGE (F-637N)

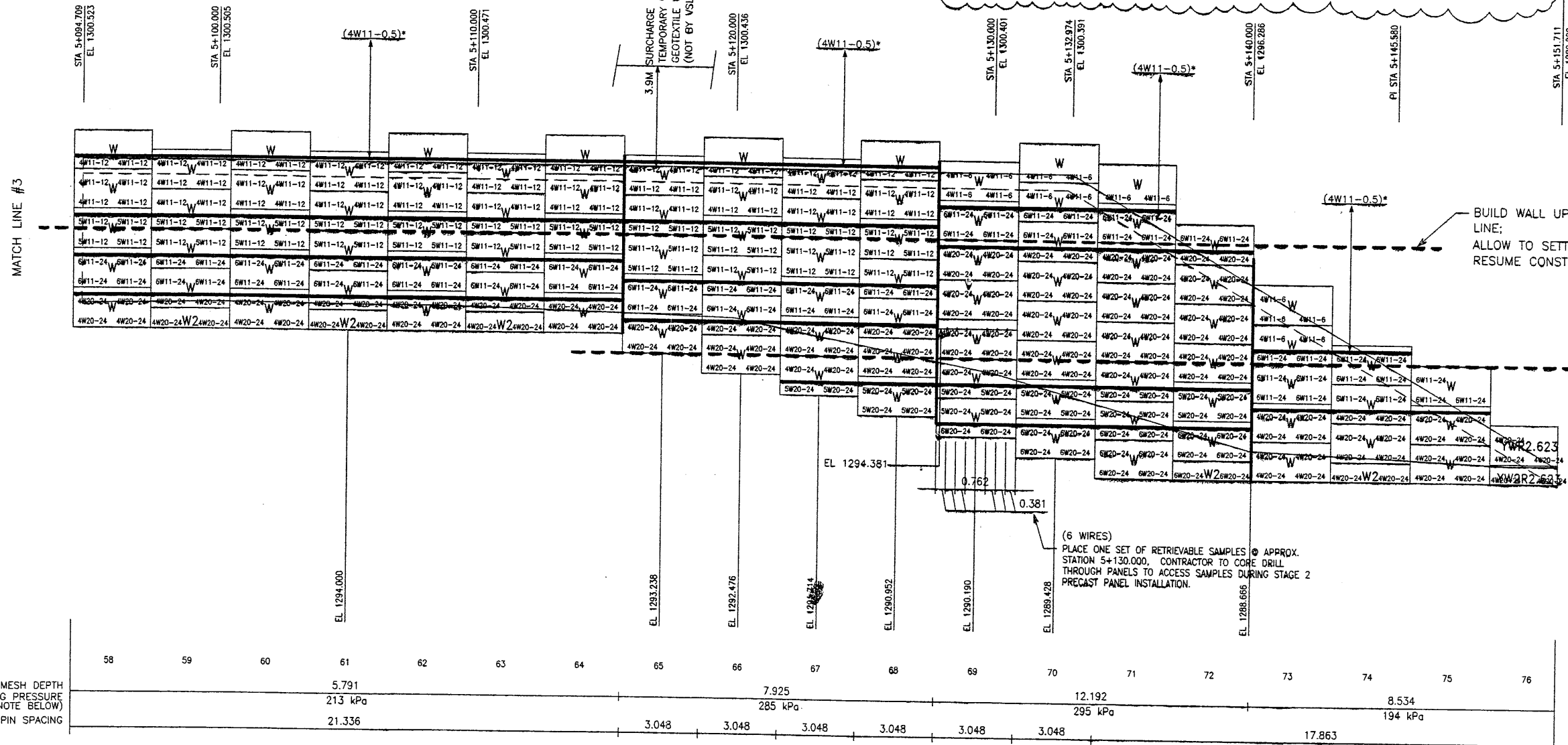

MESH DEPTH	5.791
MAXIMUM BEARING PRESSURE (SEE NOTE BELOW)	213 kPa
PIN SPACING	21.336

* INDICATES SOIL REINFORCING TYPE MESH TO BE USED ON ADDITIONAL WIRE WALL FACING ADDED AFTER SETTLEMENT.

RETAINING WALL "R-350-14" - 1ST STAGE: WIRE FACED WALL
(FRONT FACE SHOWN)

(TOTAL SURFACE AREA OF FACING = 1,528.61 SM)
SCALE 1:100 (FULL SIZE)
SCALE 1:200 (HALF SIZE)

CERTIFIED FOR INTERNAL STABILITY OF RETAINED EARTH™ STRUCTURES ONLY. EXTERNAL STABILITY, INCLUDING BUT NOT LIMITED TO FOUNDATION AND SLOPE STABILITY, IS THE RESPONSIBILITY OF THE OWNER. DESIGN IS BASED ON THE ASSUMPTION THAT THE MATERIAL WITHIN THE RETAINED EARTH™ MASS, METHODS OF CONSTRUCTION, AND QUALITY OF PREFABRICATED MATERIALS CONFORM TO THE MANUFACTURER'S SPECIFICATION.

SHT 12 OF 12
METRIC

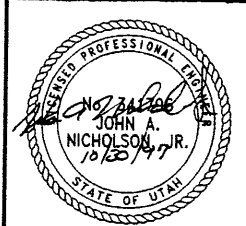

DES. 09-08-97 MM
DRN. 09-08-97 DDO
CHK. 09-08-97 MM

VSL CORPORATION
2840 Plaza Place, Suite 200
Raleigh, NC 27612
Telephone: (919) 781-6272
Fax: (919) 801-4869

RETAINED EARTH™ WALLS
WALL "R-350-14" - 1ST STAGE: WIRE FACED WALL
UTAH I-15 INTERCHANGE
SALT LAKE COUNTY, UTAH

SCALE:
3.1R-350-14.12
JOB NO:
239-0007
RE-9

REFERENCE (X-UTAH.DWG)

E:\PROJECT\239-000\13SERIES\13-114\13-114

FINAL PLOT 01-25-99

APPROVED FOR CONSTRUCTION		
NO.	DATE	DESCRIPTION
1	01-25-99	RELEASE FOR 2ND. STAGE CONSTRUCTION

BEGIN WIRE FACED WALL R-350-14
 WIRE FACED WALL STA 4+923.850 =
 I-15 STA 30+946.502
 ● 33.266 RT

MATCH BRIDGE
 (F-636N)

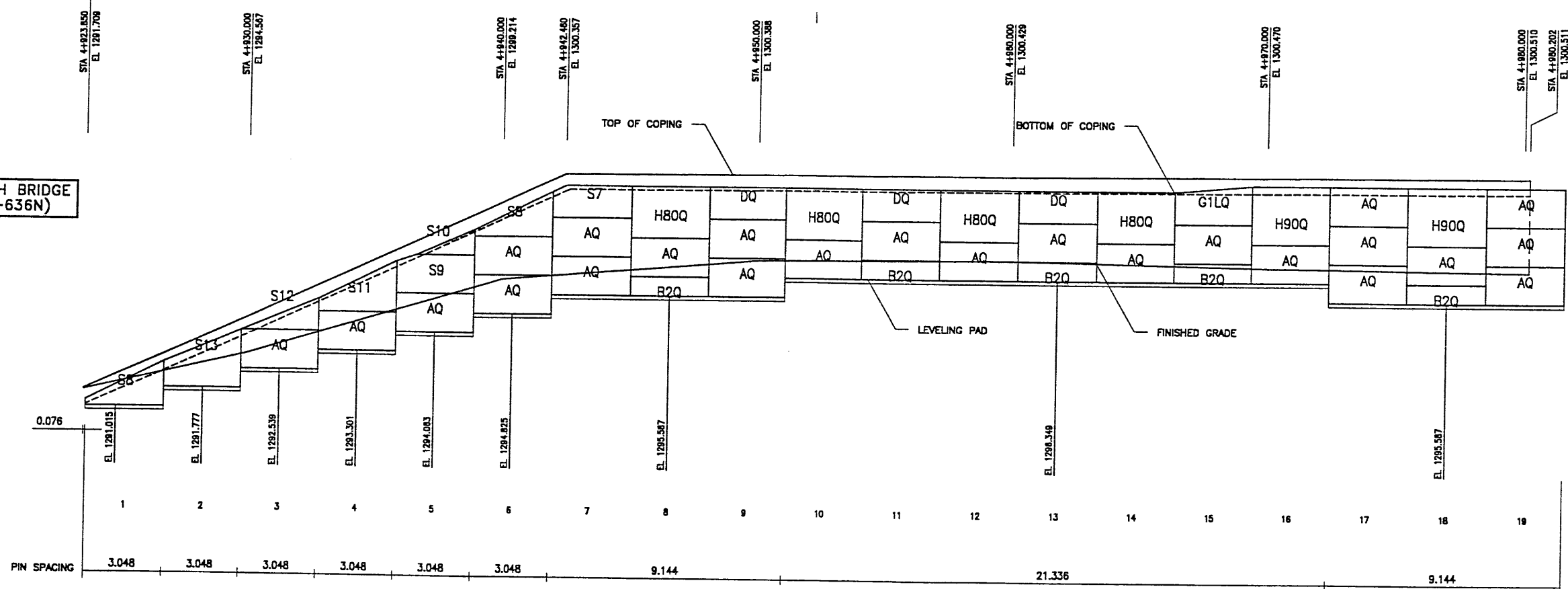

RETAINING WALL "R-350-14" - 2ND. STAGE: PRECAST WALL
 (FRONT FACE SHOWN)
 (TOTAL SURFACE AREA OF FACING = 1,172.47 SM)
 SCALE 1:100 (FULL SIZE)
 SCALE 1:200 (HALF SIZE)

METRIC

CERTIFIED FOR INTERNAL STABILITY OF RETAINED EARTH™ STRUCTURES ONLY.
 EXTERNAL STABILITY, INCLUDING BUT NOT LIMITED TO FOUNDATION AND SLOPE
 STABILITY, IS THE RESPONSIBILITY OF THE OWNER. DESIGN IS BASED ON THE
 ASSUMPTION THAT THE MATERIAL WITHIN THE RETAINED EARTH™ MASS, METHODS
 OF CONSTRUCTION, AND QUALITY OF PREFABRICATED MATERIALS CONFORM TO
 THE MANUFACTURER'S SPECIFICATION.

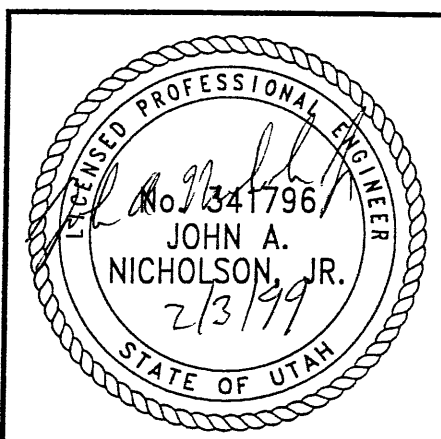

WASATCH CONSTRUCTORS
 FEB 09 1999
 RELEASED FOR CONSTRUCTION

DES.	01-25-99	JN	RETAINED EARTH™	NO.	DATE
DRN.	01-25-99	DSW			
CHK.	01-25-99	JN			
VSL CORPORATION 2940 Plaza Place, Suite 200 Raleigh, NC 27612 Telephone: (919) 781-8272 Fac: (919) 781-4869 ATLANTA, GA / DULLES, VA / AUSTIN, TX (CORPORATE OFFICE) MIAMI, FL / SAN JOSE, CA / SPRINGFIELD, IL					
RETAINED EARTH™ WALLS WALL "R-350-14" - 2ND STAGE: PRECAST WALL UTAH I-15 INTERCHANGE SALT LAKE COUNTY, UTAH UTAH DEPARTMENT OF TRANSP.					
DWG. NO. 3.1R-350-14.13					
JOB NO. 239-0007					
SH. NO. RE-10					

RFC After Final Approval

REFERENCE (X-UTAH.DWG)

E:\PROJECT\239-0007\1SERIES\13-114\13-114

FINAL PLOT 01-25-99

APPROVED FOR CONSTRUCTION		
NO.	DATE	DESCRIPTION
1	01-25-99	RELEASE FOR 2ND. STAGE CONSTRUCTION

DES.	CHK.	NO.	DATE	REVISION	BY
01-25-99	JUN				
01-25-99	DSW				
01-25-99	JUN				

VSL CORPORATION
 2840 Plaza Place, Suite 200
 Raleigh, NC 27612
 Telephone: (919) 781-8272
 Fax: (919) 781-4669

VSL

ATLANTA, GA / DALLAS, TX / BALDWIN, NC (CORPORATE OFFICE)
 MIAMI, FL / SAN JOSE, CA / SPRINGFIELD, VA

VSL Corporation (VSL) is not responsible for the design or construction of any structure which is not designed or constructed in accordance with the specifications and drawings shown on this sheet. The use of VSL's products in any structure or in any part, or any repair or alteration thereof, is the responsibility of the designer and contractor. Any other use is strictly prohibited. VSL MAKES NO WARRANTY THEREFOR.

RETAINED EARTH™ WALLS WALL "R-350-14" - 2ND STAGE: PRECAST WALL	DWG. NO. 3.1R-350-14.14
UTAH 1-15 INTERCHANGE SALT LAKE COUNTY, UTAH UTAH DEPARTMENT OF TRANSP.	JOB NO. 239-0007
	SHT. NO. RE-11

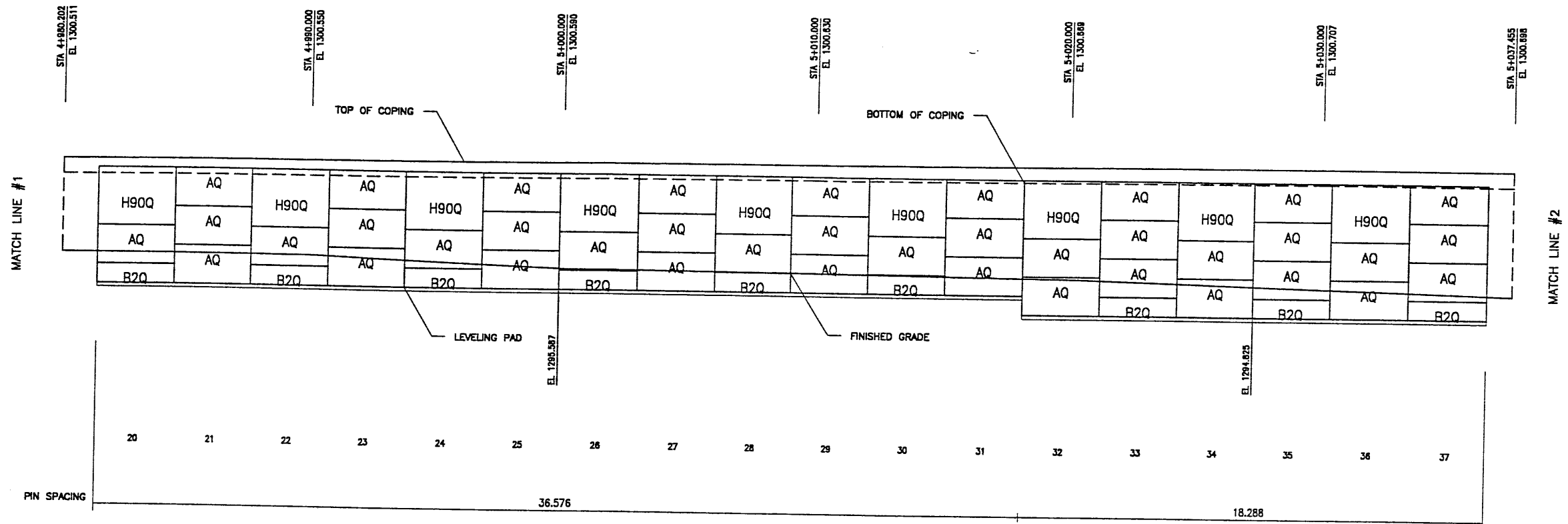

RETAINING WALL "R-350-14" - 2ND. STAGE: PRECAST WALL
 (FRONT FACE SHOWN)
 (TOTAL SURFACE AREA OF FACING = 1,172.47 SM)
 SCALE 1:100 (FULL SIZE)
 SCALE 1:200 (HALF SIZE)

WASATCH CONSTRUCTORS
 FEB 09 1999
 RELEASED FOR CONSTRUCTION

METRIC

CERTIFIED FOR INTERNAL STABILITY OF RETAINED EARTH™ STRUCTURES ONLY. EXTERNAL STABILITY, INCLUDING BUT NOT LIMITED TO FOUNDATION AND SLOPE STABILITY, IS THE RESPONSIBILITY OF THE OWNER. DESIGN IS BASED ON THE ASSUMPTION THAT THE MATERIAL WITHIN THE RETAINED EARTH™ MASS, METHODS OF CONSTRUCTION, AND QUALITY OF PREFABRICATED MATERIALS CONFORM TO THE MANUFACTURER'S SPECIFICATION.

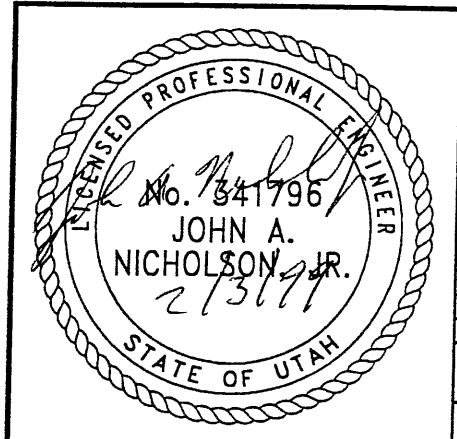

RFC After Final Approval

REFERENCE (X-UTAILDING)

E:\PROJECT\239-0007\13SERIES\13-114\13-114

FINAL PLOT 01-25-99

APPROVED FOR CONSTRUCTION		
NO.	DATE	DESCRIPTION
1	01-25-99	RELEASE FOR 2ND. STAGE CONSTRUCTION

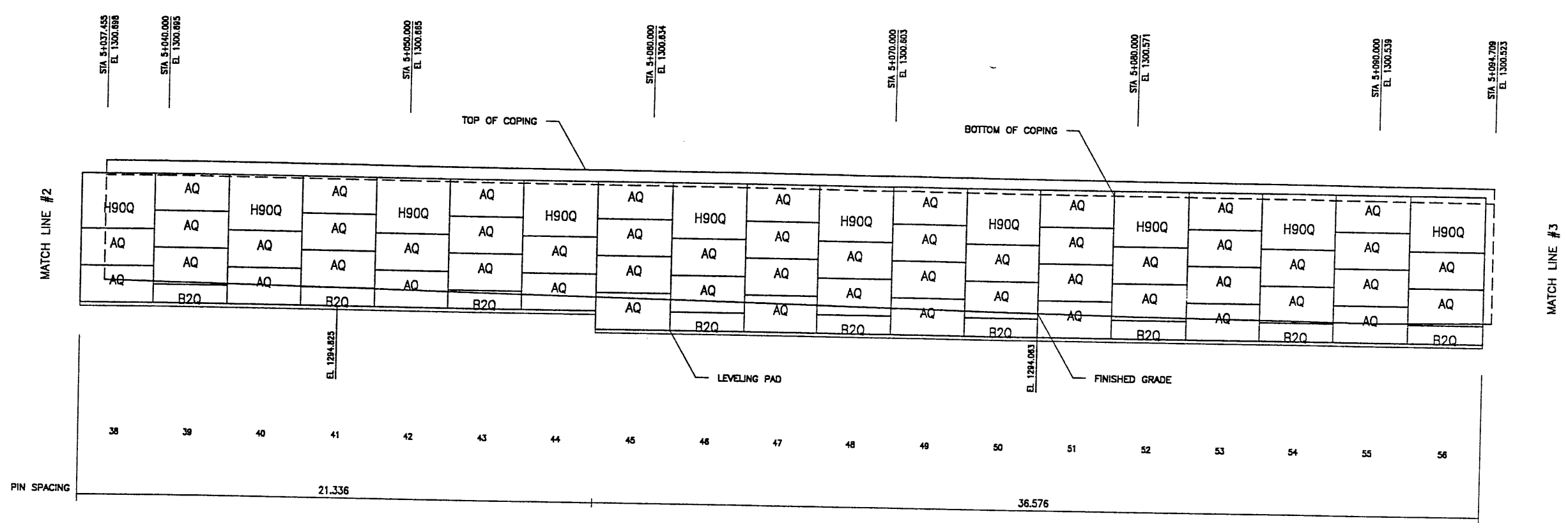

RETAINING WALL "R-350-14" - 2ND. STAGE: PRECAST WALL
 (FRONT FACE SHOWN)
 (TOTAL SURFACE AREA OF FACING = 1,172.47 SM)
 SCALE 1:100 (FULL SIZE)
 SCALE 1:200 (HALF SIZE)

WASATCH CONSTRUCTORS
 FEB 09 1999
 RELEASED FOR CONSTRUCTION

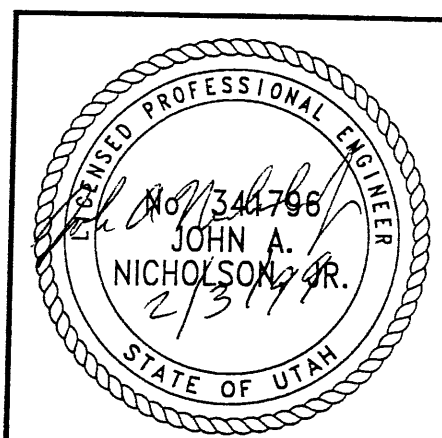

CERTIFIED FOR INTERNAL STABILITY OF RETAINED EARTH™ STRUCTURES ONLY. EXTERNAL STABILITY, INCLUDING BUT NOT LIMITED TO FOUNDATION AND SLOPE STABILITY, IS THE RESPONSIBILITY OF THE OWNER. DESIGN IS BASED ON THE ASSUMPTION THAT THE MATERIAL WITHIN THE RETAINED EARTH™ MASS, METHODS OF CONSTRUCTION, AND QUALITY OF PREFABRICATED MATERIALS CONFORM TO THE MANUFACTURER'S SPECIFICATION.

METRIC

RFC After Final Approval

DES. 01-25-99	JN
DRN. 01-25-99	DSW
CHK. 01-25-99	JN
RETAINED EARTH™	
VSL CORPORATION 2840 Plaza Place, Suite 200 Raleigh, NC 27612 Telephone: (919) 781-8272 Fax: (919) 781-4959	
ALANTA, GA / DALLAS, TX / RALEIGH, NC (CORPORATE OFFICE) MIAMI, FL / SAN JOSE, CA / SPRINGFIELD, VA	
<p>RETAINED EARTH™ WALLS WALL "R-350-14" - 2ND STAGE: PRECAST WALL UTAH I-15 INTERCHANGE SALT LAKE COUNTY, UTAH UTAH DEPARTMENT OF TRANSP.</p>	
DWG. NO.	3.1R-350-14.15
JOB NO.	239-0007
SHT. NO.	RE-12

REFERENCE (X-UTAH.DWG)

E:\PROJECT\239-0007\1SERIES\13-114\13-114

FINAL PLOT 01-25-99

APPROVED FOR CONSTRUCTION		
NO.	DATE	DESCRIPTION
1	01-25-99	RELEASE FOR 2ND. STAGE CONSTRUCTION

END WIRE FACED WALL R-350-14
 WIRE FACED WALL STA 5+151.814 =
 1-15 STA 31+166.359
 @ 30.714 RT

MATCH BRIDGE
 (F-637N)

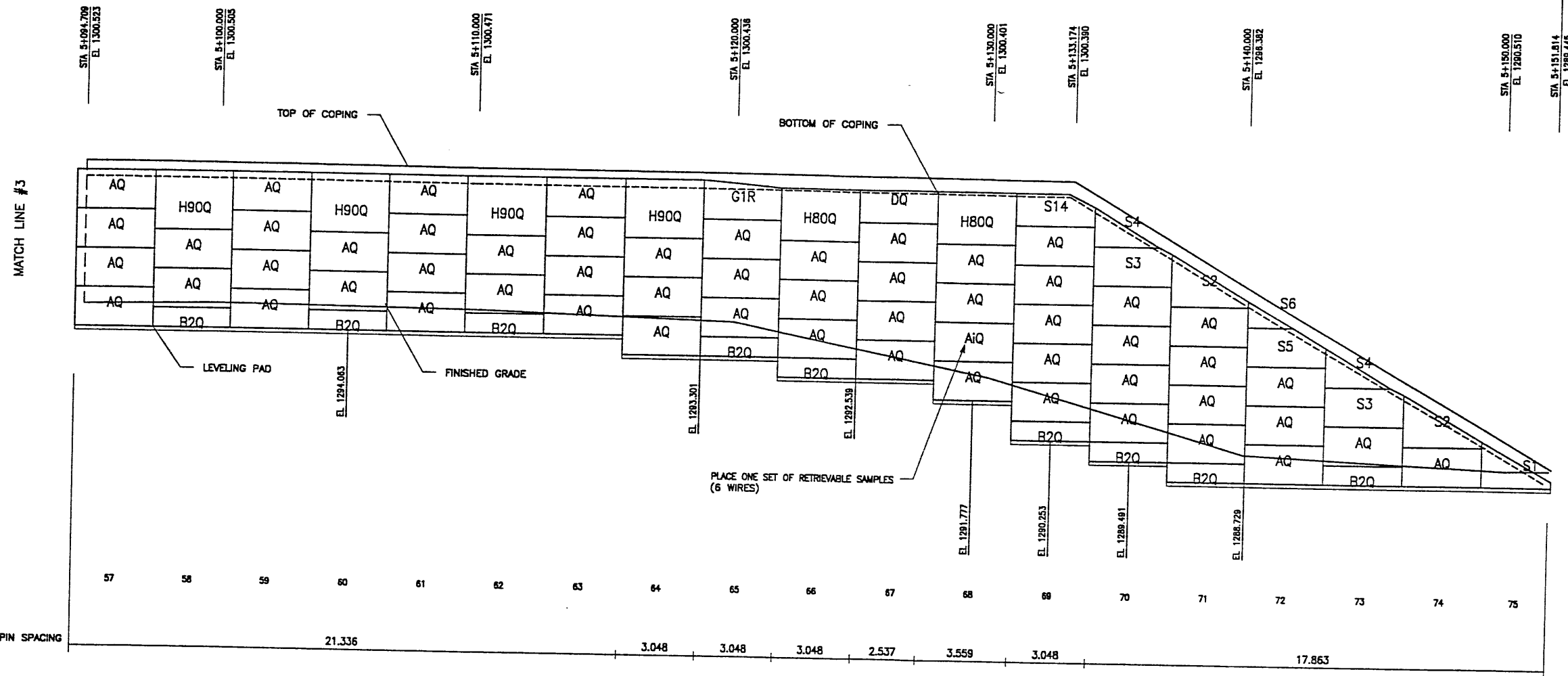

RETAINING WALL "R-350-14" - 2ND. STAGE: PRECAST WALL
 (FRONT FACE SHOWN) SCALE 1:100 (FULL SIZE)
 (TOTAL SURFACE AREA OF FACING = 1,172.47 SM) SCALE 1:200 (HALF SIZE)

WASATCH CONSTRUCTORS
 FEB 09 1999
 RELEASED FOR CONSTRUCTION

METRIC

CERTIFIED FOR INTERNAL STABILITY OF RETAINED EARTH™ STRUCTURES ONLY. EXTERNAL STABILITY, INCLUDING BUT NOT LIMITED TO FOUNDATION AND SLOPE STABILITY, IS THE RESPONSIBILITY OF THE OWNER. DESIGN IS BASED ON THE ASSUMPTION THAT THE MATERIAL WITHIN THE RETAINED EARTH™ MASS, METHODS OF CONSTRUCTION, AND QUALITY OF PREFABRICATED MATERIALS CONFORM TO THE MANUFACTURER'S SPECIFICATION.

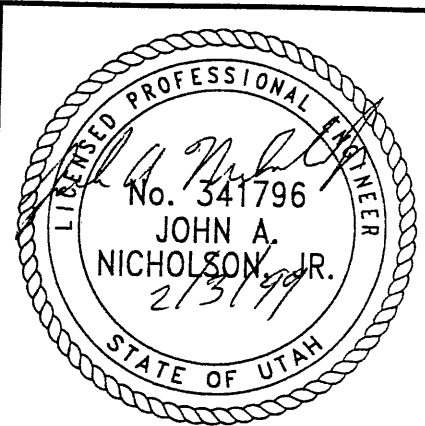

RETAINED EARTH™ WALLS
 WALL "R-350-14" - 2ND STAGE: PRECAST WALL
 UTAH I-15 INTERCHANGE
 SALT LAKE COUNTY, UTAH
 UTAH DEPARTMENT OF TRANSP.

DWG. NO.	3.1R-350-14.16
JOB NO.	239-0007
SH. NO.	RE-13

VSL CORPORATION
 2810 Plaza Place, Suite 200
 Raleigh, NC 27617
 Telephone: (919) 781-8272
 Fax: (919) 781-4889

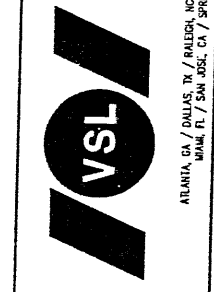

VSL Corporation (VSL) is an equal opportunity employer. Minorities and women are encouraged to apply. The use of VSL products is not a warranty of performance. VSL is not responsible for any damage or injury to the retained earth or to the structure or to the user of the product. VSL is not responsible for any damage or injury to the retained earth or to the structure or to the user of the product. VSL is not responsible for any damage or injury to the retained earth or to the structure or to the user of the product.

NO.	DATE	DESCRIPTION	REVISION	BY	CHK

RFC After Final Approval

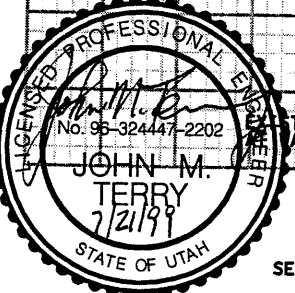
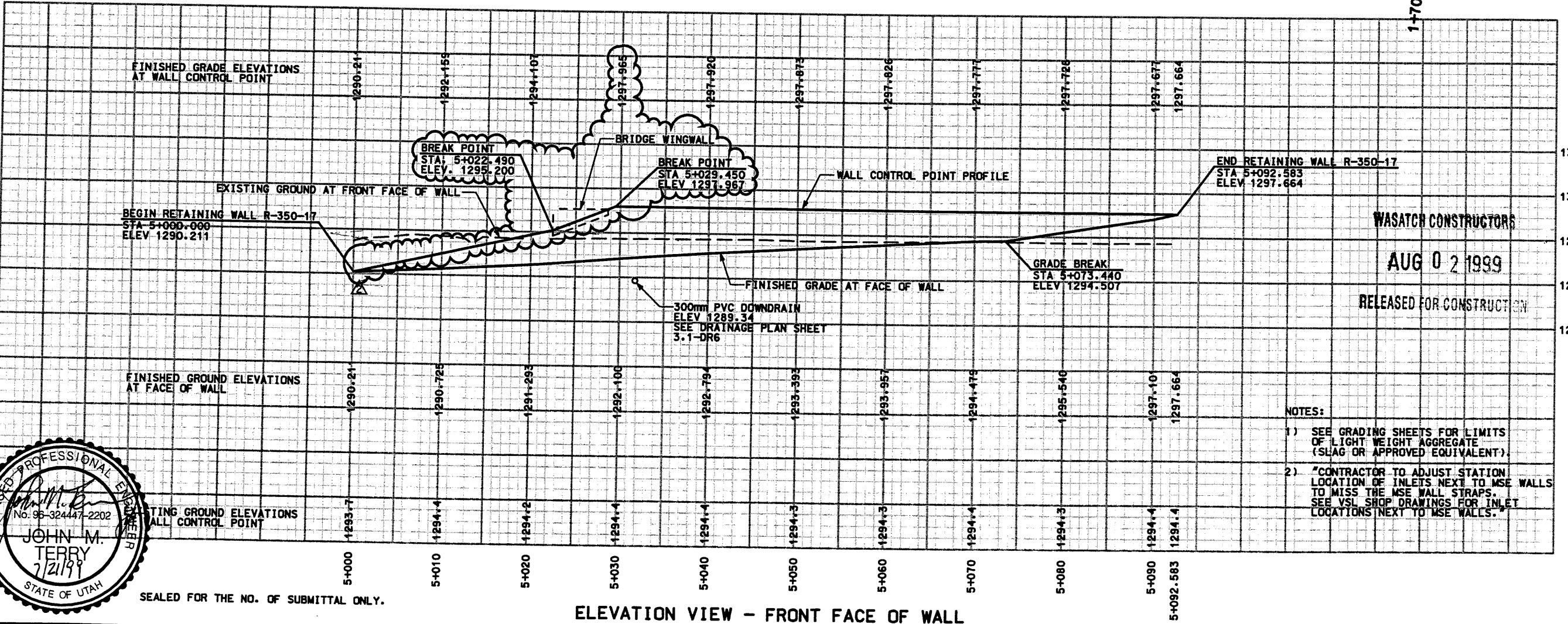
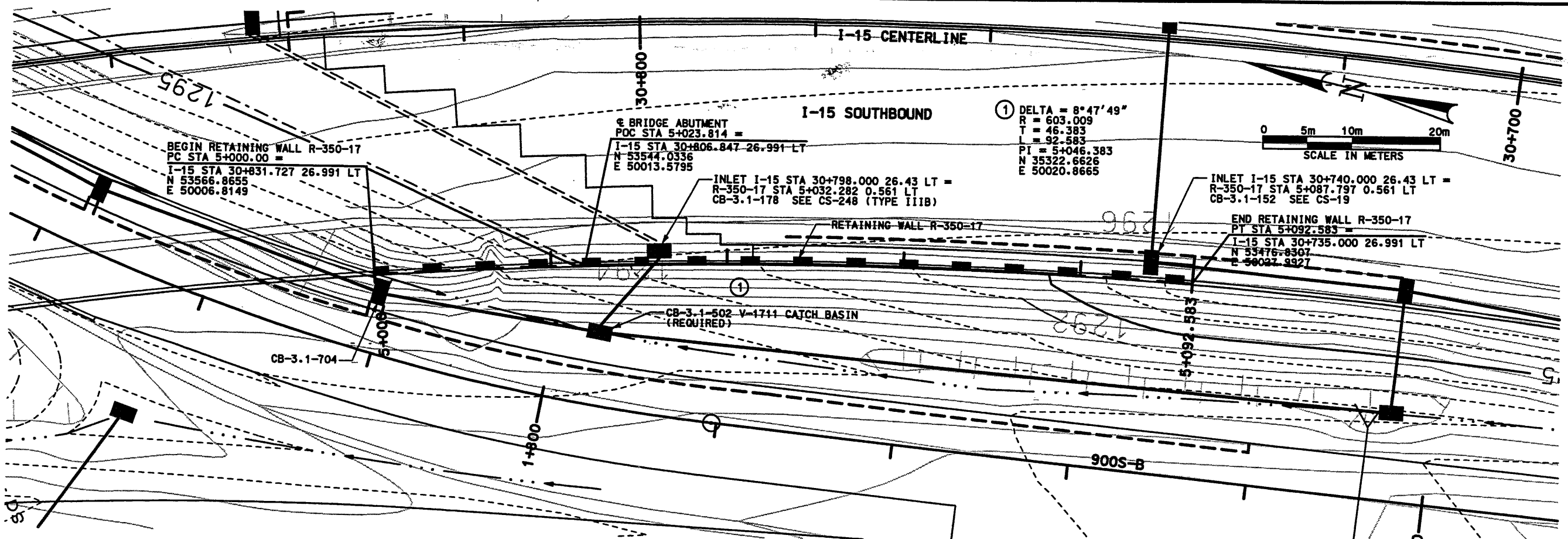

SEALED FOR THE NO. OF SUBMITTAL ONLY.

ELEVATION VIEW - FRONT FACE OF WALL

- NOTES:
- 1) SEE GRADING SHEETS FOR LIMITS OF LIGHT WEIGHT AGGREGATE (SLAG OR APPROVED EQUIVALENT).
 - 2) CONTRACTOR TO ADJUST STATION LOCATION OF INLETS NEXT TO MSE WALLS TO MISS THE MSE WALL STRAPS. SEE VSL SHOP DRAWINGS FOR INLET LOCATIONS NEXT TO MSE WALLS.

APPROVED FOR CONSTRUCTION		NO.	DATE	DESCRIPTION
△		11/20/98		ORIGINAL ISSUE
△		7/21/99		REVISED PROFILE, MDC-033
△		///	///	///
△		///	///	///
				WBS NO. 3113403
UTAH DEPARTMENT OF TRANSPORTATION MK CENTENNIAL SVERDRUP/DE LEUW				
I-15 CORRIDOR RECONSTRUCTION SITUATION & LAYOUT R-350-17 SECTION 3.I		DESIGN MGR. 7/01/98	CHECK C.J.D. 7/01/98	
		APPROVAL DATE 11/20/98	RECOMM. DATE 11/20/98	
		PROJECT DESIGN ENGINEER	SECTION MANAGER	
		Bret A. Reynolds	REYNOLDS, J. ROBB	
PROJECT NUMBER #SP-15-(7135)296				
RELEASED FOR CONSTRUCTION AUG 02 1999 WASATCH CONSTRUCTORS				
SALT LAKE COUNTY DWG. NO. 3.1R-350-17.1				
SHT. 1 OF 15				

Filename: p:\vgn\115_cood\13_s7_sheet_files\wall13_r1\wall-T_0.dgn Date: 17-NOV-1998 Time: 10:21 User: mmaolseno

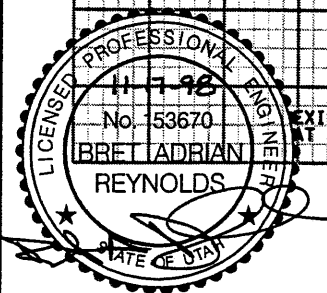
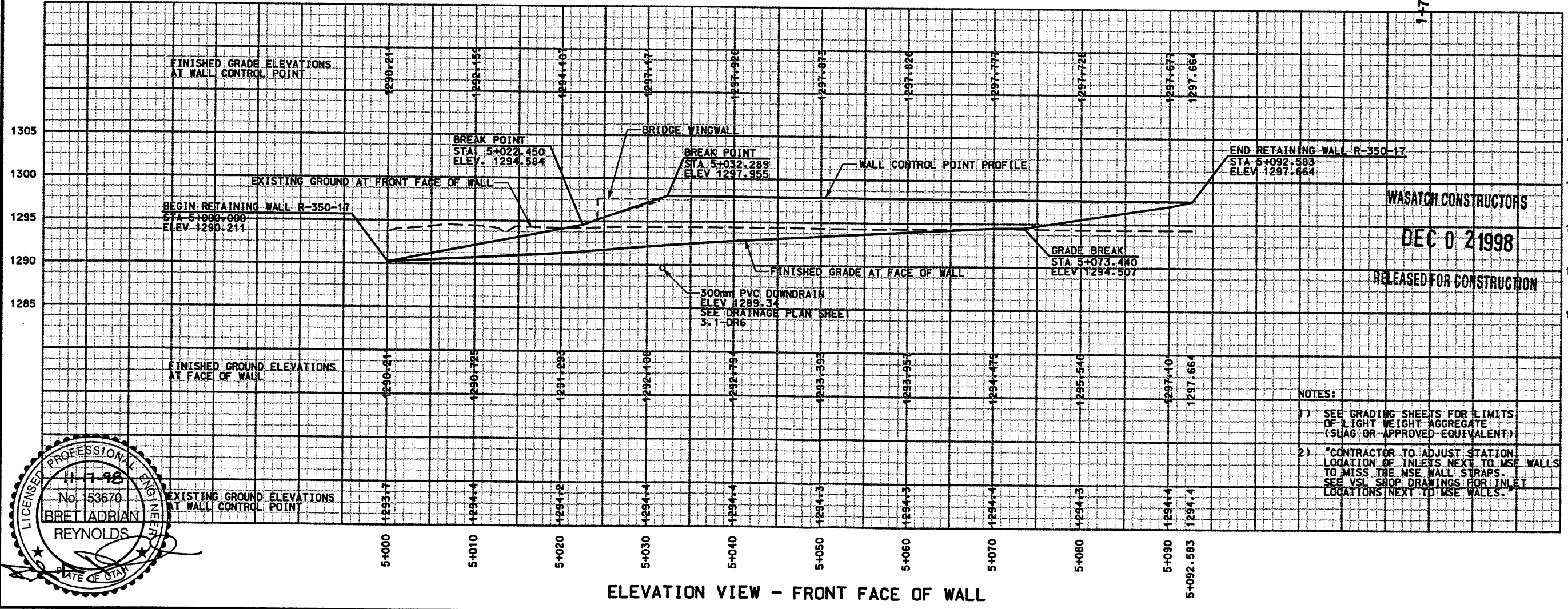
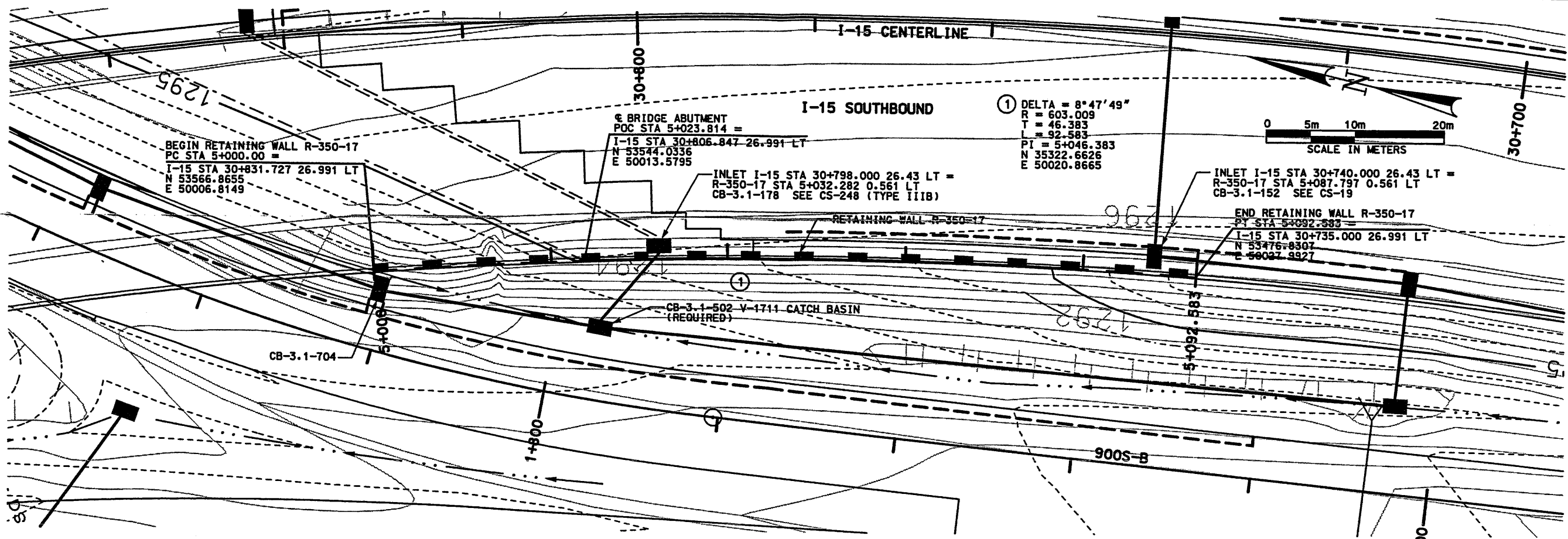

APPROVED FOR CONSTRUCTION		DESCRIPTION	
NO.	DATE	NO.	DATE
Δ	11/20/98	Δ	11/20/98
Δ	11/20/98	Δ	11/20/98
Δ	11/20/98	Δ	11/20/98
Δ	11/20/98	Δ	11/20/98
UTAH DEPARTMENT OF TRANSPORTATION M&K CENTENNIAL SYVERDRUP/DE LEUW		WBS NO. 8113403	
DESIGN MGR 7/01/98		CHECK CJO 7/01/98	
DRAWN MGR 7/01/98		CHECK CJO 7/01/98	
QUANT.		CHECK	
APPROVAL 11/20/98		DATE 11/20/98	
PROJECT DESIGN ENGINEER		SECTION MANAGER	
Bret A. Reynolds		Randle L. Ross	
DATE 11/20/98		DATE 11/20/98	
PROJECT NUMBER #SP-15-7(135)296		SECTION 3.1	
SALT LAKE COUNTY		DWG. NO. 3.1R-350-17.1	
SHT. 1 OF 15			

Date: 17-NOV-1998 Time: 10:26 User: hansen.dlsncj

RETAINING WALL DETAILS

WALL R-350-17
(1-STAGE MSE WALL)
NTS

NOTES:

- 1) SEE CORRIDOR STANDARD SPECIFICATION 221 FOR BENCHING AND SPECIAL EXCAVATION REQUIREMENTS WHERE GROUNDWATER IS EXPECTED AT OR ABOVE THE REQUIRED EXCAVATION.
- 2) FOUNDATION BEARING MATERIALS SHALL BE OBSERVED BY THE GEOTECHNICAL ENGINEER DURING SITE PREPARATION. ANY UNDESIRABLE MATERIALS SHALL BE REMOVED AND REPLACED IN ORDER TO ACHIEVE ACCEPTABLE CONDITIONS AT THE BASE OF THE WALL.
- 3) LIGHT WEIGHT AGGREGATE (LWA) AS DEFINED IN CORRIDOR STANDARD SPECIFICATION 220B SHALL BE BLAST FURNACE SLAG (90 TO 95 PCF) OR APPROVED EQUIVALENT.
- 4) SEE GRADING SHEET 3.1-GR6 FOR LIMITS OF LWA AND CROSS SECTION SHEET 3.1-XS12 FOR DEPTH TO BOTTOM OF LWA.
- 5) SELECT MATERIAL FOR MSE REINFORCED ZONE SHALL BE AS DEFINED IN CORRIDOR STANDARD SPECIFICATION 525.
- 6) OVEREXCAVATE EXISTING SOILS TO DEPTH (D) BENEATH WALL AS SHOWN. STRUCTURAL FILL SHALL BE USED BENEATH THE WALL WITH D = 0.6m MINIMUM. FOR (D) DIMENSION SEE VSL DRAWINGS.
- 7) CONSTRUCT CLAY CAP PER CORRIDOR STANDARD SPECIFICATION 526 (0.3m THICK).
- 8) SEE VSL DRAWINGS FOR EMBEDMENT DEPTH (d).

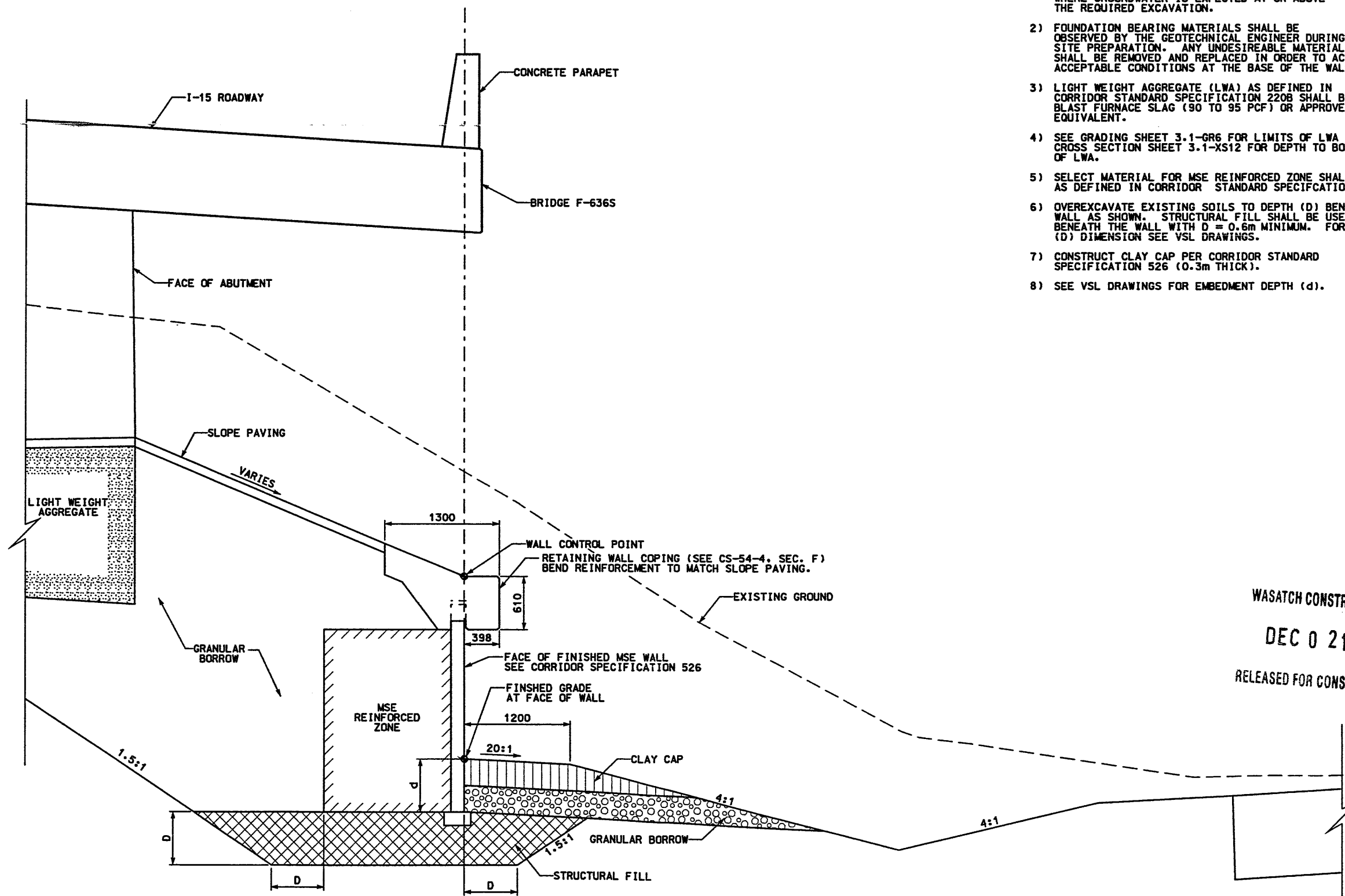

WASATCH CONSTRUCTORS
DEC 0 2 1998
RELEASED FOR CONSTRUCTION



DETAIL A
5+000.00 TO 5+022.45

APPROVED FOR CONSTRUCTION		DESCRIPTION	
NO.	DATE	NO.	DATE
1	11/20/98	1	11/20/98
2	/ /	2	/ /
3	/ /	3	/ /
4	/ /	4	/ /

UTAH DEPARTMENT OF TRANSPORTATION M/K CENTENNIAL SVERDRUP/DE LEUW	WBS NO. 3113403
DESIGN MGR 7/01/98 CHECK CJO 7/01/98	DRAWN MGR 7/01/98 CHECK CJO 7/01/98
APPROVAL DATE 11/20/98 RECOMM. 11/20/98	PROJECT DESIGN ENGINEER DATE 11/20/98
	PROJECT MANAGER DATE 11/20/98

I-15 CORRIDOR RECONSTRUCTION WALL DETAIL R-350-17	SALT LAKE COUNTY
SECTION 3.1	DWG. NO. 3.1R-350-17.2
PROJECT NUMBER #SP-15-7(135)296	

SHT. 2 OF 15	REF.
--------------	------

RETAINING WALL DETAILS

**WALL R-350-17
(1-STAGE MSE WALL)
NTS**

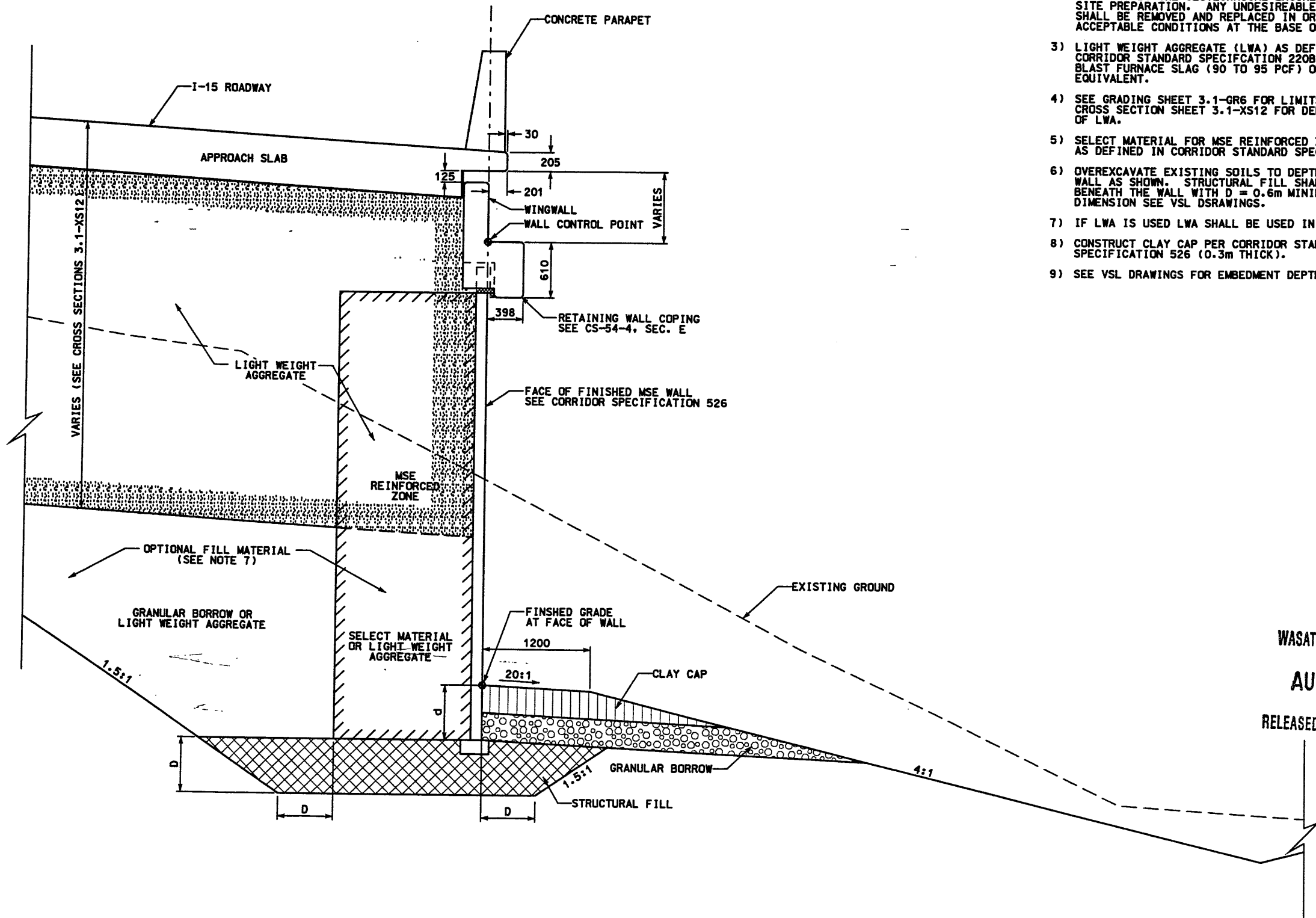

NOTES:

- 1) SEE CORRIDOR STANDARD SPECIFICATION 221 FOR BENCHING AND SPECIAL EXCAVATION REQUIREMENTS WHERE GROUNDWATER IS EXPECTED AT OR ABOVE THE REQUIRED EXCAVATION.
- 2) FOUNDATION BEARING MATERIALS SHALL BE OBSERVED BY THE GEOTECHNICAL ENGINEER DURING SITE PREPARATION. ANY UNDESIRABLE MATERIALS SHALL BE REMOVED AND REPLACED IN ORDER TO ACHIEVE ACCEPTABLE CONDITIONS AT THE BASE OF THE WALL.
- 3) LIGHT WEIGHT AGGREGATE (LWA) AS DEFINED IN CORRIDOR STANDARD SPECIFICATION 220B SHALL BE BLAST FURNACE SLAG (90 TO 95 PCF) OR APPROVED EQUIVALENT.
- 4) SEE GRADING SHEET 3.1-GR6 FOR LIMITS OF LWA AND CROSS SECTION SHEET 3.1-XS12 FOR DEPTH TO BOTTOM OF LWA.
- 5) SELECT MATERIAL FOR MSE REINFORCED ZONE SHALL BE AS DEFINED IN CORRIDOR STANDARD SPECIFICATION 525.
- 6) OVEREXCAVATE EXISTING SOILS TO DEPTH (D) BENEATH WALL AS SHOWN. STRUCTURAL FILL SHALL BE USED BENEATH THE WALL WITH D = 0.6m MINIMUM. FOR (D) DIMENSION SEE VSL DRAWINGS.
- 7) IF LWA IS USED LWA SHALL BE USED IN BOTH AREAS.
- 8) CONSTRUCT CLAY CAP PER CORRIDOR STANDARD SPECIFICATION 526 (0.3m THICK).
- 9) SEE VSL DRAWINGS FOR EMBEDMENT DEPTH (d).

DETAIL B

5+022.45 TO 5+028.66

WASATCH CONSTRUCTORS
AUG 0 2 1999
RELEASED FOR CONSTRUCTION

User: homet wall
Date: 21-Jul-1999 Time: 08:45
Filename: c:\p1\15_cadd\13_97\sheet_files\wall\3_ret\wall-17_03_rev



SEALED FOR THE NO. OF SUBMITTAL ONLY.

APPROVED FOR CONSTRUCTION		DESCRIPTION	
NO.	DATE	NO.	DATE
Δ	11/20/98	Δ	7/21/99
Δ	7/21/99	Δ	7/21/99
Δ	7/21/99	Δ	7/21/99
Δ	7/21/99	Δ	7/21/99
UTAH DEPARTMENT OF TRANSPORTATION		WBS NO. 3113403	
MK CENTENNIAL		DESIGN MGR 7/01/98	
SVERDRUP/DE LEUW		CHECK CJD 7/01/98	
PROJECT DESIGN ENGINEER		DRAWN MGR 7/01/98	
Bret A. Reynolds		CHECK CJD 7/01/98	
DATE 11/20/98		CHECK CJD 7/01/98	
PROJECT MANAGER		CHECK	
Randle L. Ross		QUANT.	
DATE 11/20/98		QUANT.	
PROJECT NUMBER		QUANT.	
#SP-15-7(135)296		QUANT.	
I-15 CORRIDOR RECONSTRUCTION		QUANT.	
WALL DETAIL R-350-17		QUANT.	
SECTION 3.1		QUANT.	
COUNTY		QUANT.	
SALT LAKE		QUANT.	
DWG. NO.		QUANT.	
3.1R-350-17.3		QUANT.	
SHT. 3 OF 15		QUANT.	
REF.		QUANT.	

RFC After Final Approval

RETAINING WALL DETAILS

WALL R-350-17
(1-STAGE MSE WALL)
NTS

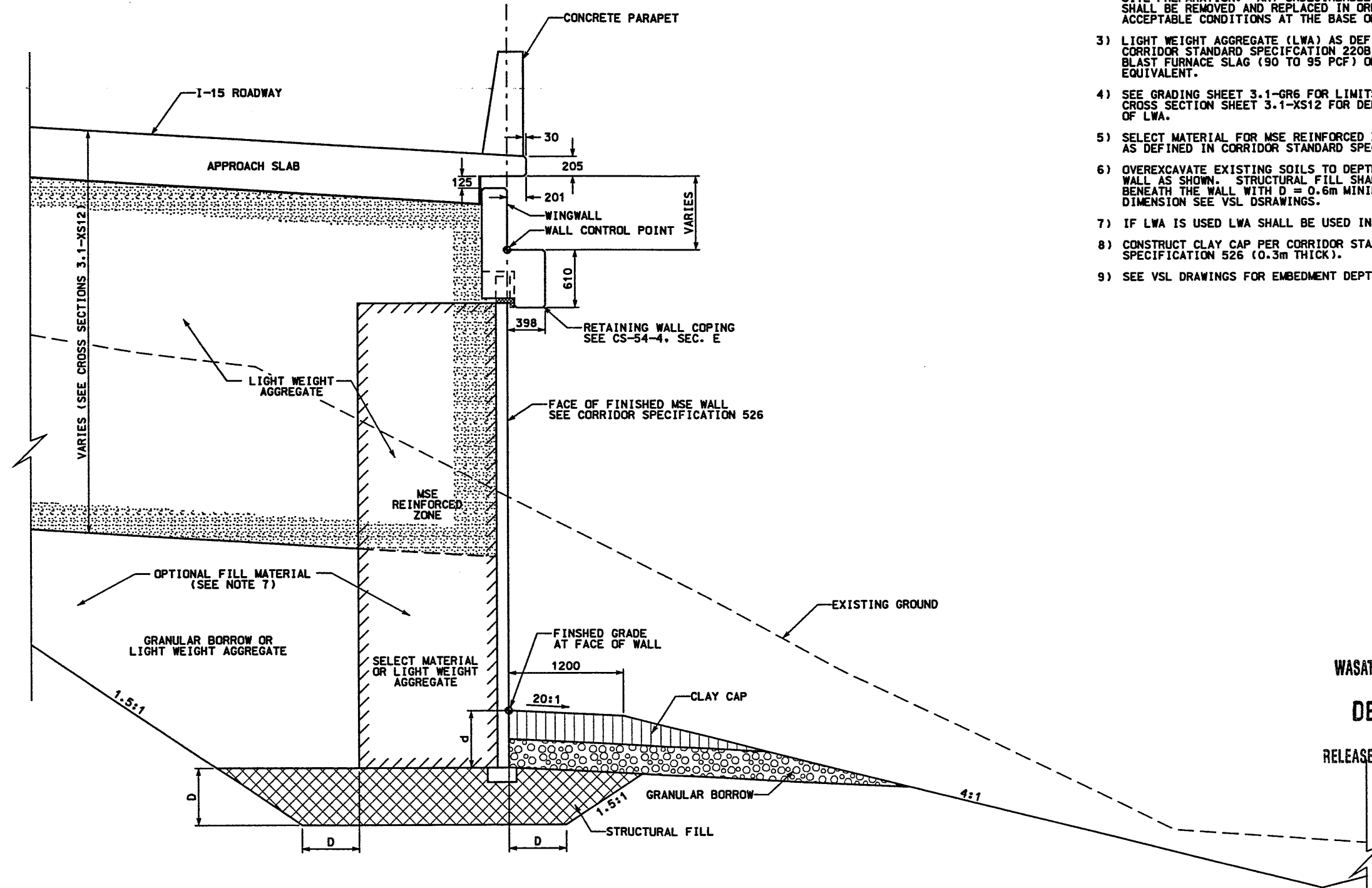

NOTES:

- 1) SEE CORRIDOR STANDARD SPECIFICATION 221 FOR BENCHING AND SPECIAL EXCAVATION REQUIREMENTS WHERE GROUNDWATER IS EXPECTED AT OR ABOVE THE REQUIRED EXCAVATION.
- 2) FOUNDATION BEARING MATERIALS SHALL BE OBSERVED BY THE GEOTECHNICAL ENGINEER DURING SITE PREPARATION. ANY UNDESIRABLE MATERIALS SHALL BE REMOVED AND REPLACED IN ORDER TO ACHIEVE ACCEPTABLE CONDITIONS AT THE BASE OF THE WALL.
- 3) LIGHT WEIGHT AGGREGATE (LWA) AS DEFINED IN CORRIDOR STANDARD SPECIFICATION 220B SHALL BE BLAST FURNACE SLAG (90 TO 95 PCF) OR APPROVED EQUIVALENT.
- 4) SEE GRADING SHEET 3.1-GR6 FOR LIMITS OF LWA AND CROSS SECTION SHEET 3.1-XS12 FOR DEPTH TO BOTTOM OF LWA.
- 5) SELECT MATERIAL FOR MSE REINFORCED ZONE SHALL BE AS DEFINED IN CORRIDOR STANDARD SPECIFICATION 525.
- 6) OVEREXCAVATE EXISTING SOILS TO DEPTH (D) BENEATH WALL AS SHOWN. STRUCTURAL FILL SHALL BE USED BENEATH THE WALL WITH D = 0.6m MINIMUM. FOR (D) DIMENSION SEE VSL DRAWINGS.
- 7) IF LWA IS USED LWA SHALL BE USED IN BOTH AREAS.
- 8) CONSTRUCT CLAY CAP PER CORRIDOR STANDARD SPECIFICATION 526 (0.3m THICK).
- 9) SEE VSL DRAWINGS FOR EMBEDMENT DEPTH (d).



DETAIL B
5+022.45 TO 5+031.32

WASATCH CONSTRUCTORS
DEC 0 2 1998
RELEASED FOR CONSTRUCTION

APPROVED FOR CONSTRUCTION		DESCRIPTION	
NO.	DATE	NO.	DATE
△	11/20/98	△	11/20/98
△	11/20/98	△	11/20/98
△	11/20/98	△	11/20/98
△	11/20/98	△	11/20/98
UTAH DEPARTMENT OF TRANSPORTATION M.K. CENTENNIAL SVDRUP/DE LEUW		DESIGN MGN	7/01/98
I-15 CORRIDOR RECONSTRUCTION WALL DETAIL R-350-17		CHECK CJD	7/01/98
SECTION 3.1		DESIGN MGN	7/01/98
PROJECT NUMBER #SP-15-711351296		DRAWN MGN	7/01/98
SALT LAKE COUNTY		CHECK	11/20/98
DWG. NO. 3.1R-350-17.3		QUANT.	11/20/98
SHT. 3 OF 15		PROJECT MANAGER	REYNOLDS
REF.		DATE	11/20/98

RETAINING WALL DETAILS

WALL R-350-17
(1-STAGE MSE WALL)
NTS

NOTES:

- 1) SEE CORRIDOR STANDARD SPECIFICATION 221 FOR BENCHING AND SPECIAL EXCAVATION REQUIREMENTS WHERE GROUNDWATER IS EXPECTED AT OR ABOVE THE REQUIRED EXCAVATION.
- 2) FOUNDATION BEARING MATERIALS SHALL BE OBSERVED BY THE GEOTECHNICAL ENGINEER DURING SITE PREPARATION. ANY UNDESIRABLE MATERIALS SHALL BE REMOVED AND REPLACED IN ORDER TO ACHIEVE ACCEPTABLE CONDITIONS AT THE BASE OF THE WALL.
- 3) LIGHT WEIGHT AGGREGATE (LWA) AS DEFINED IN CORRIDOR STANDARD SPECIFICATION 220B SHALL BE BLAST FURNACE SLAG (90 TO 95 PCF) OR APPROVED EQUIVALENT.
- 4) SEE GRADING SHEET 3.1-GR6 FOR LIMITS OF LWA AND CROSS SECTION SHEET 3.1-XS12 FOR DEPTH TO BOTTOM OF LWA.
- 5) SELECT MATERIAL FOR MSE REINFORCED ZONE SHALL BE AS DEFINED IN CORRIDOR STANDARD SPECIFICATION 525.
- 6) OVEREXCAVATE EXISTING SOILS TO DEPTH (D) BENEATH WALL AS SHOWN. STRUCTURAL FILL SHALL BE USED BENEATH THE WALL WITH D = 0.6m MINIMUM. FOR (D) DIMENSION SEE VSL DRAWINGS
- 7) IF LWA IS USED LWA SHALL BE USED IN BOTH AREAS.
- 8) CONSTRUCT CLAY CAP PER CORRIDOR STANDARD SPECIFICATION 526 (0.3m THICK).
- 9) SEE VSL DRAWINGS FOR EMBEDMENT DEPTH (d).

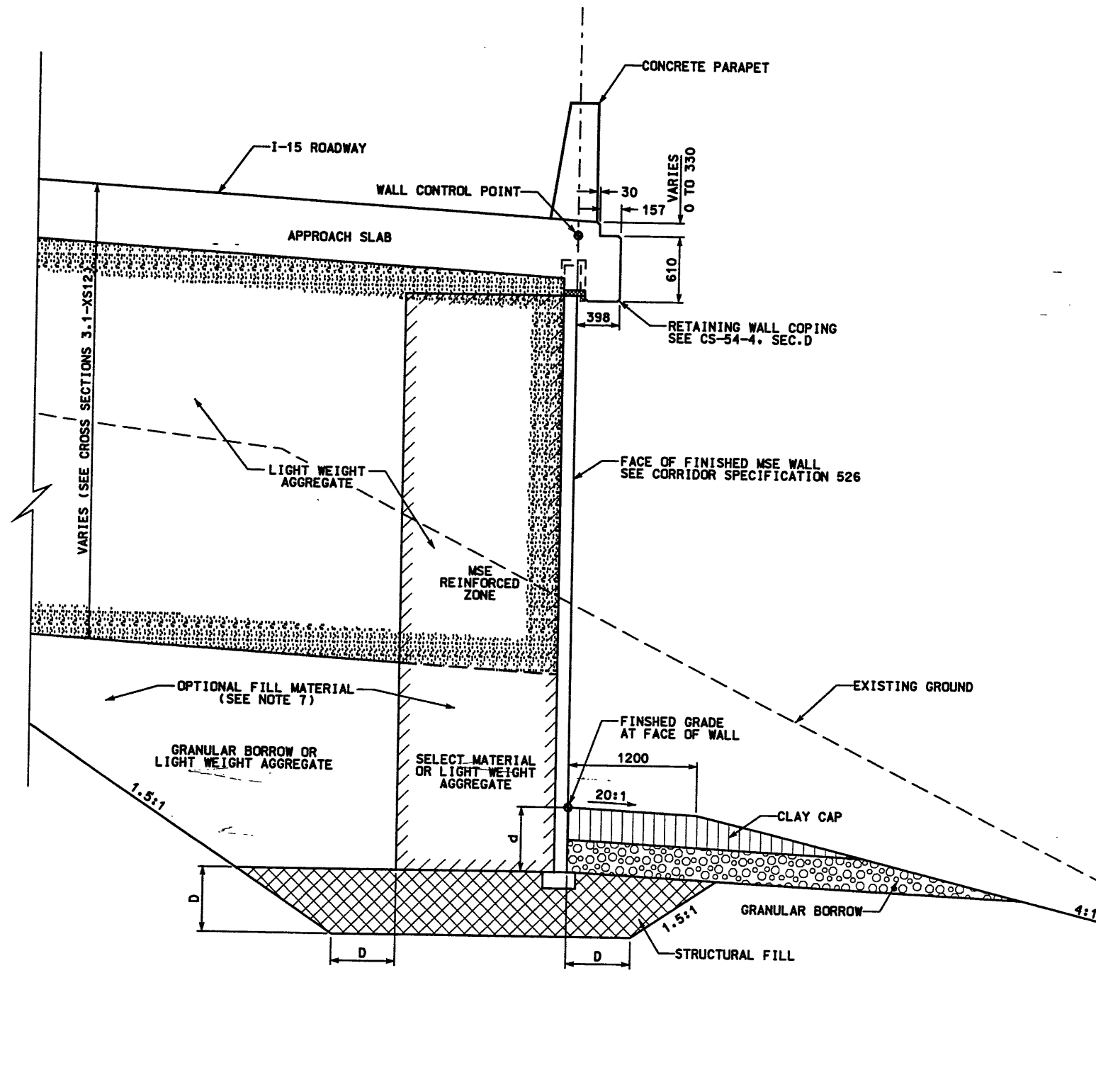

DETAIL C

5+028.66 TO 5+029.49

WASATCH CONSTRUCTORS
AUG 02 1999
RELEASED FOR CONSTRUCTION

User: rnmw1

Date: 2-Jul-1999 Time: 08:21



SEALED FOR THE NO. OF SUBMITTAL ONLY.

APPROVED FOR CONSTRUCTION		DESCRIPTION	
NO.	DATE	NO.	DATE
1	11/20/98	1	11/20/98
2	7/21/99	2	7/21/99
3		3	
4		4	

DESIGN	MON	7/01/98	CHECK	CJD	7/01/98
DRAWN	MON	7/01/98	CHECK	CJD	7/01/98
PROJECT DESIGNER	Bret A. Reynolds				
PROJECT MANAGER	Randie L. Ross				
QUANT.	/	/	/	/	/

UTAH DEPARTMENT OF TRANSPORTATION	WBS NO.
MK CENTENNIAL	3113403
SVERDRUP/DE LEUW	

I-15 CORRIDOR RECONSTRUCTION	SECTION 3.1
WALL DETAIL R-350-17	#SP-15-7(135)296
COUNTY	SALT LAKE
DWG. NO.	3.1R-350-17.4
SHT.	4 OF 15

RFC After Final Approve!

Users: name: oleanoj Date: 17-NOV-98 Time: 10:31 File: c:\p1\15_r\sheet\15_r\wall-17_04.dgn

RETAINING WALL DETAILS

WALL R-350-17
(1-STAGE MSE WALL)
NTS

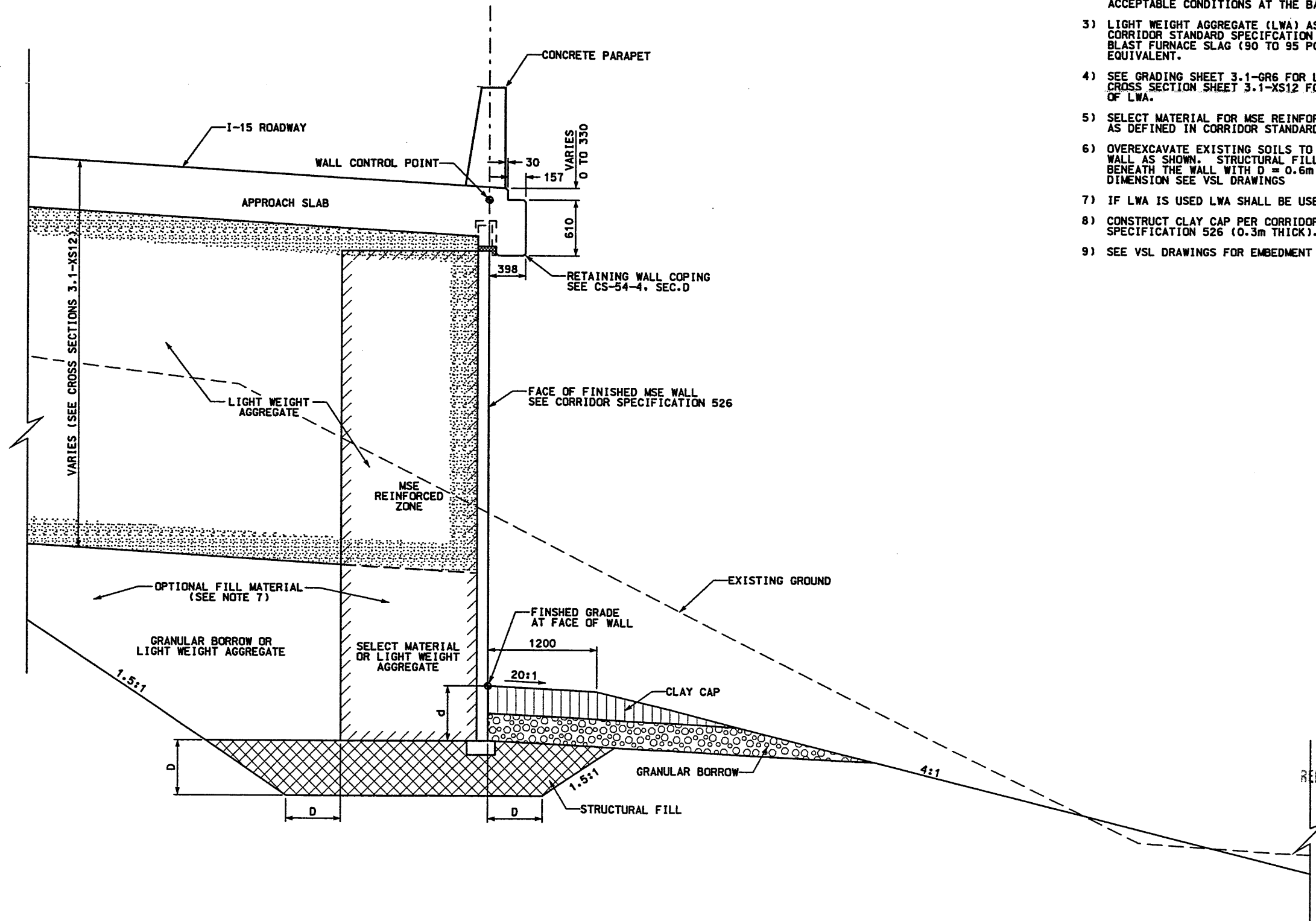

NOTES:

- 1) SEE CORRIDOR STANDARD SPECIFICATION 221 FOR BENCHING AND SPECIAL EXCAVATION REQUIREMENTS WHERE GROUNDWATER IS EXPECTED AT OR ABOVE THE REQUIRED EXCAVATION.
- 2) FOUNDATION BEARING MATERIALS SHALL BE OBSERVED BY THE GEOTECHNICAL ENGINEER DURING SITE PREPARATION. ANY UNDESIREABLE MATERIALS SHALL BE REMOVED AND REPLACED IN ORDER TO ACHIEVE ACCEPTABLE CONDITIONS AT THE BASE OF THE WALL.
- 3) LIGHT WEIGHT AGGREGATE (LWA) AS DEFINED IN CORRIDOR STANDARD SPECIFICATION 220B SHALL BE BLAST FURNACE SLAG (90 TO 95 PCF) OR APPROVED EQUIVALENT.
- 4) SEE GRADING SHEET 3.1-GR6 FOR LIMITS OF LWA AND CROSS SECTION SHEET 3.1-XS12 FOR DEPTH TO BOTTOM OF LWA.
- 5) SELECT MATERIAL FOR MSE REINFORCED ZONE SHALL BE AS DEFINED IN CORRIDOR STANDARD SPECIFICATION 525.
- 6) OVEREXCAVATE EXISTING SOILS TO DEPTH (D) BENEATH WALL AS SHOWN. STRUCTURAL FILL SHALL BE USED BENEATH THE WALL WITH D = 0.6m MINIMUM. FOR (D) DIMENSION SEE VSL DRAWINGS
- 7) IF LWA IS USED LWA SHALL BE USED IN BOTH AREAS.
- 8) CONSTRUCT CLAY CAP PER CORRIDOR STANDARD SPECIFICATION 526 (0.3m THICK).
- 9) SEE VSL DRAWINGS FOR EMBEDMENT DEPTH (d).

APPROVED FOR CONSTRUCTION

NO.	DATE	DESCRIPTION
1	11/20/98	ORIGINAL ISSUE
2	/ /	/ /
3	/ /	/ /
4	/ /	/ /

UTAH DEPARTMENT OF TRANSPORTATION
MK CENTENNIAL
SVDRDRUP/DE LELUW

DESIGN	11/20/98	Bret A. Reynolds	DESIGN ENGINEER	CHECK	7/01/98	CJD	7/01/98	WBS NO.	3113403
DRAWN	11/20/98	Randle J. Robb	PROJECT DESIGN ENGINEER	CHECK	7/01/98	CJD	7/01/98		
APPROVED	11/20/98		PROJECT MANAGER	QUANT.	/ /				

WASATCH CONSTRUCTORS
DEC 0 2 1998
RELEASED FOR CONSTRUCTION

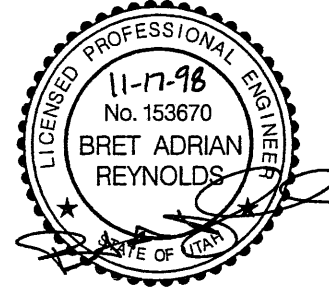

DETAIL C
5+031.32 TO 5+032.29

PROJECT NUMBER	#SP-15-7(135)296
COUNTY	SALT LAKE
DWG. NO.	3.1R-350-17.4
SHT.	4 OF 15
REF.	

RETAINING WALL DETAILS

WALL R-350-17
(1-STAGE MSE WALL)
NTS

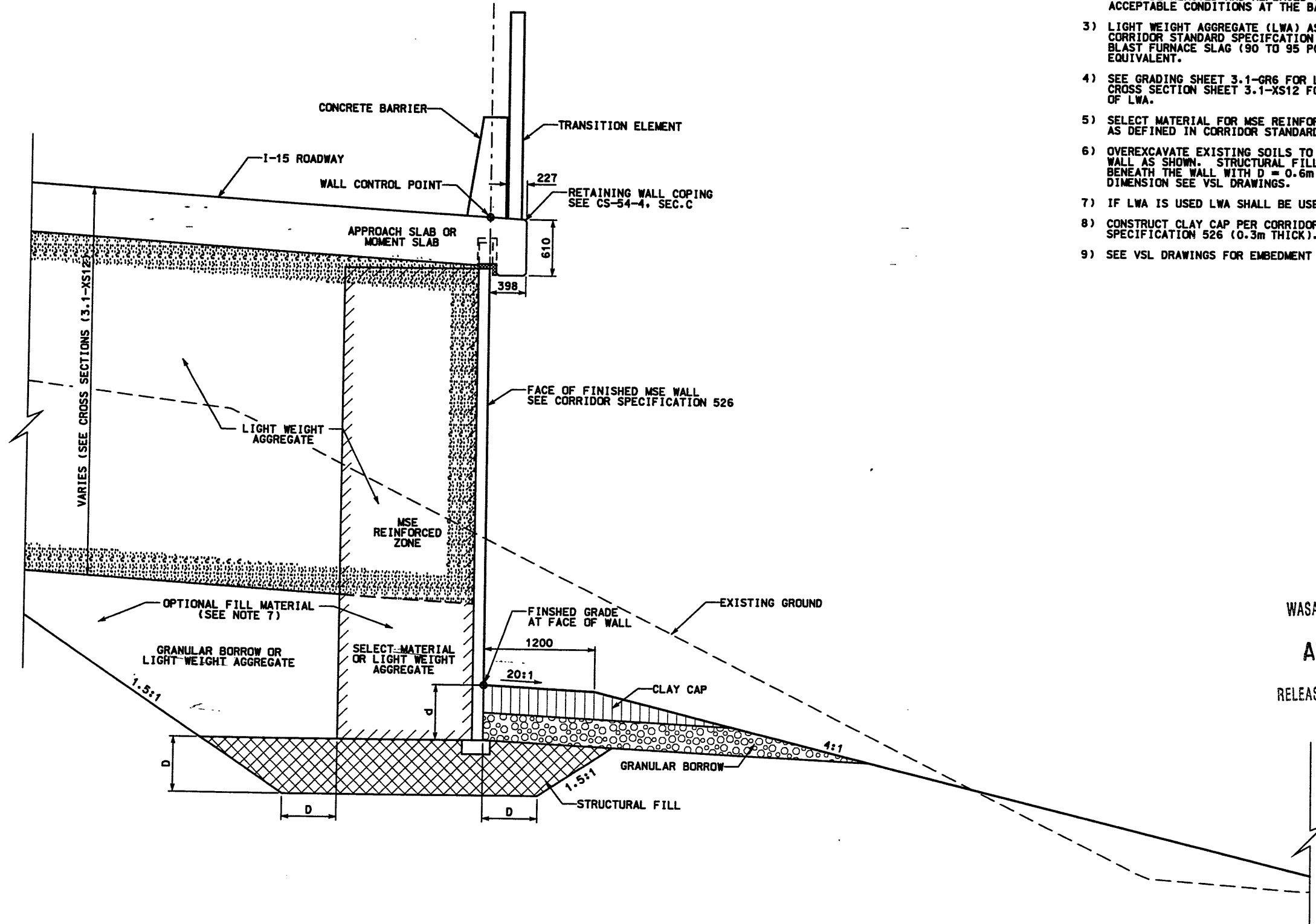

NOTES:

- 1) SEE CORRIDOR STANDARD SPECIFICATION 221 FOR BENCHING AND SPECIAL EXCAVATION REQUIREMENTS WHERE GROUNDWATER IS EXPECTED AT OR ABOVE THE REQUIRED EXCAVATION.
- 2) FOUNDATION BEARING MATERIALS SHALL BE OBSERVED BY THE GEOTECHNICAL ENGINEER DURING SITE PREPARATION. ANY UNDESIRABLE MATERIALS SHALL BE REMOVED AND REPLACED IN ORDER TO ACHIEVE ACCEPTABLE CONDITIONS AT THE BASE OF THE WALL.
- 3) LIGHT WEIGHT AGGREGATE (LWA) AS DEFINED IN CORRIDOR STANDARD SPECIFICATION 2208 SHALL BE BLAST FURNACE SLAG (90 TO 95 PCF) OR APPROVED EQUIVALENT.
- 4) SEE GRADING SHEET 3.1-GR6 FOR LIMITS OF LWA AND CROSS SECTION SHEET 3.1-XS12 FOR DEPTH TO BOTTOM OF LWA.
- 5) SELECT MATERIAL FOR MSE REINFORCED ZONE SHALL BE AS DEFINED IN CORRIDOR STANDARD SPECIFICATION 525.
- 6) OVEREXCAVATE EXISTING SOILS TO DEPTH (D) BENEATH WALL AS SHOWN. STRUCTURAL FILL SHALL BE USED BENEATH THE WALL WITH D = 0.6m MINIMUM. FOR (D) DIMENSION SEE VSL DRAWINGS.
- 7) IF LWA IS USED LWA SHALL BE USED IN BOTH AREAS.
- 8) CONSTRUCT CLAY CAP PER CORRIDOR STANDARD SPECIFICATION 526 (0.3m THICK).
- 9) SEE VSL DRAWINGS FOR EMBEDMENT DEPTH (d).

WASATCH CONSTRUCTORS
AUG 02 1999
RELEASED FOR CONSTRUCTION

DETAIL D
5+029.49 TO 5+044.38

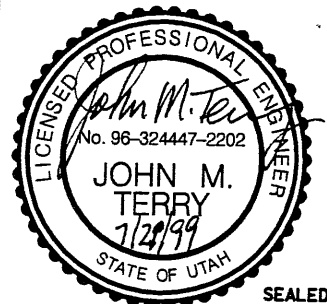

SEALED FOR THE NO. OF SUBMITTAL ONLY.

APPROVED FOR CONSTRUCTION		DESCRIPTION	
NO.	DATE	NO.	DATE
1	11/20/98	1	11/20/98
2	7/21/99	2	7/21/99
3	/ /	3	/ /
4	/ /	4	/ /
UTAH DEPARTMENT OF TRANSPORTATION MX CENTENNIAL SYVERDRUP/DE LEUW		WBS NO. 3119409	
DESIGN MGR	7/01/98	CHECK CJD	7/01/98
DRAWN MGR	7/01/98	CHECK CJD	7/01/98
PROJECT DESIGN ENGINEER		QUANT.	
PROJECT MANAGER			
PERSONAL RECORD	11/20/98	DATE	11/20/98
DATE	11/20/98	DATE	11/20/98
PROJECT NUMBER	#SP-15-7(135)296		
COUNTY	SALT LAKE		
DWG. NO.	3.1R-350-17.5		
SHT.	5 OF 15		
REF.			

RFC After Final Approval

Usernames: ciberno] Date: 17-Nov-1998 Time: 10:36

Filename: c:\dgn\115_oodd\13_371\sheet_115.dwg\13_retwall-17_05.dgn

RETAINING WALL DETAILS

WALL R-350-17
(1-STAGE MSE WALL)
NTS

NOTES:

- 1) SEE CORRIDOR STANDARD SPECIFICATION 221 FOR BENCHING AND SPECIAL EXCAVATION REQUIREMENTS WHERE GROUNDWATER IS EXPECTED AT OR ABOVE THE REQUIRED EXCAVATION.
- 2) FOUNDATION BEARING MATERIALS SHALL BE OBSERVED BY THE GEOTECHNICAL ENGINEER DURING SITE PREPARATION. ANY UNDESIRABLE MATERIALS SHALL BE REMOVED AND REPLACED IN ORDER TO ACHIEVE ACCEPTABLE CONDITIONS AT THE BASE OF THE WALL.
- 3) LIGHT WEIGHT AGGREGATE (LWA) AS DEFINED IN CORRIDOR STANDARD SPECIFICATION 220B SHALL BE BLAST FURNACE SLAG (90 TO 95 PCF) OR APPROVED EQUIVALENT.
- 4) SEE GRADING SHEET 3.1-GR6 FOR LIMITS OF LWA AND CROSS SECTION SHEET 3.1-XS12 FOR DEPTH TO BOTTOM OF LWA.
- 5) SELECT MATERIAL FOR MSE REINFORCED ZONE SHALL BE AS DEFINED IN CORRIDOR STANDARD SPECIFICATION 525.
- 6) OVEREXCAVATE EXISTING SOILS TO DEPTH (D) BENEATH WALL AS SHOWN. STRUCTURAL FILL SHALL BE USED BENEATH THE WALL WITH D = 0.6m MINIMUM. FOR (D) DIMENSION SEE VSL DRAWINGS.
- 7) IF LWA IS USED LWA SHALL BE USED IN BOTH AREAS.
- 8) CONSTRUCT CLAY CAP PER CORRIDOR STANDARD SPECIFICATION 526 (0.3m THICK).
- 9) SEE VSL DRAWINGS FOR EMBEDMENT DEPTH (d).

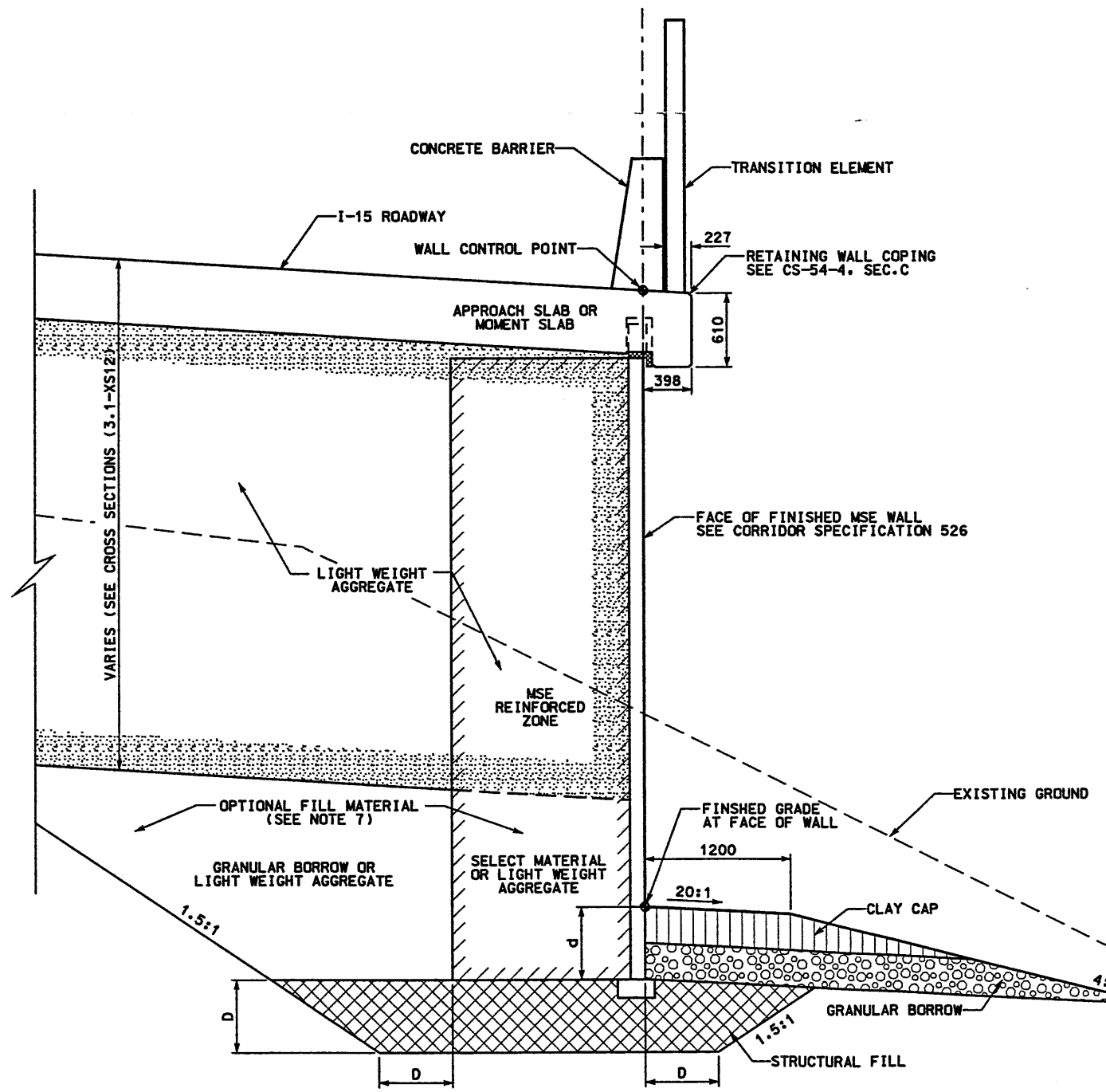

WASATCH CONSTRUCTORS
DEC 0 2 1998
RELEASED FOR CONSTRUCTION



DETAIL D
5+032.29 TO 5+044.38

APPROVED FOR CONSTRUCTION		DESCRIPTION	
NO.	DATE	ORIGINAL ISSUE	DATE
1	11/20/98	/ /	/ /
UTAH DEPARTMENT OF TRANSPORTATION		WBS NO.	
MK CENTENNIAL		3113403	
SVERDRUP/DE LEUW		DESIGN	CHECK
DATE	DATE	DATE	DATE
11/20/98	7/01/98	7/01/98	7/01/98
Bret A. Reynolds		PROJECT DESIGN ENGINEER	
DATE		DATE	
11/20/98		7/01/98	
Randle L. Ross		PROJECT MANAGER	
DATE		DATE	
11/20/98		/ /	
1-15 CORRIDOR RECONSTRUCTION		SECTION 3.1	
WALL DETAIL R-350-17		PROJECT NUMBER	
SECTION 3.1		#SP-15-7(135)296	
SALT LAKE COUNTY		DWG. NO.	
3.1R-350-17.5		SHT. 5 OF 15	
REF.		REF.	

Filename: c:\dgn\15.cadd\13_97\sheet_files\wall13_rctwall-11.06.dgn Date: 17-NOV-1998 Time: 00:39 User: rames.oleanoj

RETAINING WALL DETAILS

WALL R-350-17
 (1-STAGE MSE WALL)
 NTS

NOTES:

- 1) SEE CORRIDOR STANDARD SPECIFICATION 221 FOR BENCHING AND SPECIAL EXCAVATION REQUIREMENTS WHERE GROUNDWATER IS EXPECTED AT OR ABOVE THE REQUIRED EXCAVATION.
- 2) FOUNDATION BEARING MATERIALS SHALL BE OBSERVED BY THE GEOTECHNICAL ENGINEER DURING SITE PREPARATION. ANY UNDESIREABLE MATERIALS SHALL BE REMOVED AND REPLACED IN ORDER TO ACHIEVE ACCEPTABLE CONDITIONS AT THE BASE OF THE WALL.
- 3) LIGHT WEIGHT AGGREGATE (LWA) AS DEFINED IN CORRIDOR STANDARD SPECIFICATION 220B SHALL BE BLAST FURNACE SLAG (90 TO 95 PCF) OR APPROVED EQUIVALENT.
- 4) SEE GRADING SHEET 3.1-GR6 FOR LIMITS OF LWA AND CROSS SECTION SHEET 3.1-XS12 FOR DEPTH TO BOTTOM OF LWA.
- 5) SELECT MATERIAL FOR MSE REINFORCED ZONE SHALL BE AS DEFINED IN CORRIDOR STANDARD SPECIFICATION 525.
- 6) OVEREXCAVATE EXISTING SOILS TO DEPTH (D) BENEATH WALL AS SHOWN. STRUCTURAL FILL SHALL BE USED BENEATH THE WALL WITH D = 0.6m MINIMUM. FOR (D) DIMENSION SEE VSL DRAWINGS.
- 7) IF LWA IS USED LWA SHALL BE USED IN BOTH AREAS.
- 8) CONSTRUCT CLAY CAP PER CORRIDOR STANDARD SPECIFICATION 526 (0.3m THICK).
- 9) SEE VSL DRAWINGS FOR EMBEDMENT DEPTH (d).

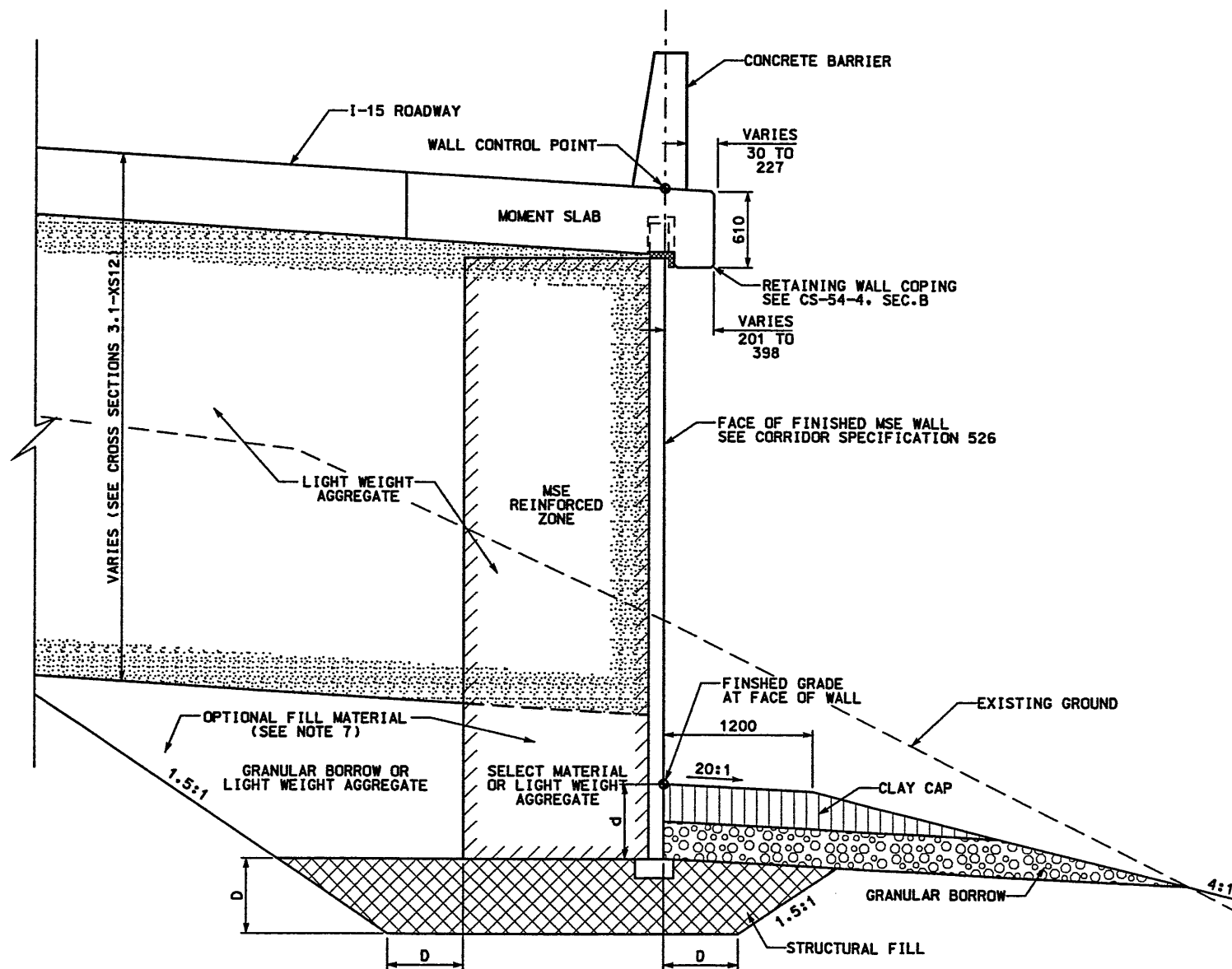

DETAIL E
 5+044.38 TO 5+047.43



WASATCH CONSTRUCTORS
DEC 0 2 1998
 RELEASED FOR CONSTRUCTION

APPROVED FOR CONSTRUCTION		DESCRIPTION	
NO.	DATE	ORIG. ISSUE	DATE
△	11/20/98	/ /	/ /
UTAH DEPARTMENT OF TRANSPORTATION		WBS NO.	
MIX CENTENNIAL		3113403	
SVERDRUP/DE LEUW		DESIGN MGR	7/01/98
Bret A. Reynolds		CHECK CJO	7/01/98
PROJECT DESIGN ENGINEER		DRAWN MGR	7/01/98
DATE 11/20/98		CHECK CJO	7/01/98
APPROVED 11/20/98		QUANT.	/ /
Randy L. Ross		PROJECT MANAGER	/ /
DATE 11/20/98			
I-15 CORRIDOR RECONSTRUCTION	WALL DETAIL R-350-17		
SECTION 3.1	PROJECT NUMBER		
#SP-15-7(135)296			
SALT LAKE COUNTY			
DWG. NO.			
3.1R-350-17.6			
SHT. 6	OF 15		
REF.			

Username: oisenoj Date: 17-NOV-1999 Time: 10:42

Filename: c:\dgn\115...sheet...files\wall13_r_etwall-17.07.dgn

RETAINING WALL DETAILS

WALL R-350-17
(1-STAGE MSE WALL)
NTS

NOTES:

- 1) SEE CORRIDOR STANDARD SPECIFICATION 221 FOR BENCHING AND SPECIAL EXCAVATION REQUIREMENTS WHERE GROUNDWATER IS EXPECTED AT OR ABOVE THE REQUIRED EXCAVATION.
- 2) FOUNDATION BEARING MATERIALS SHALL BE OBSERVED BY THE GEOTECHNICAL ENGINEER DURING SITE PREPARATION. ANY UNDESIRABLE MATERIALS SHALL BE REMOVED AND REPLACED IN ORDER TO ACHIEVE ACCEPTABLE CONDITIONS AT THE BASE OF THE WALL.
- 3) LIGHT WEIGHT AGGREGATE (LWA) AS DEFINED IN CORRIDOR STANDARD SPECIFICATION 220B SHALL BE BLAST FURNACE SLAG (90 TO 95 PCF) OR APPROVED EQUIVALENT.
- 4) SEE GRADING SHEET 3.1-GR6 FOR LIMITS OF LWA AND CROSS SECTION SHEET 3.1-XS12 FOR DEPTH TO BOTTOM OF LWA.
- 5) SELECT MATERIAL FOR MSE REINFORCED ZONE SHALL BE AS DEFINED IN CORRIDOR STANDARD SPECIFICATION 525.
- 6) OVEREXCAVATE EXISTING SOILS TO DEPTH (D) BENEATH WALL AS SHOWN. STRUCTURAL FILL SHALL BE USED BENEATH THE WALL WITH D = 0.6m MINIMUM. FOR (D) DIMENSION SEE VSL DRAWINGS.
- 7) IF LWA IS USED LWA SHALL BE USED IN BOTH AREAS.
- 8) CONSTRUCT CLAY CAP PER CORRIDOR STANDARD SPECIFICATION 526 (0.3m THICK).
- 9) SEE VSL DRAWINGS FOR EMBEDMENT DEPTH (d).

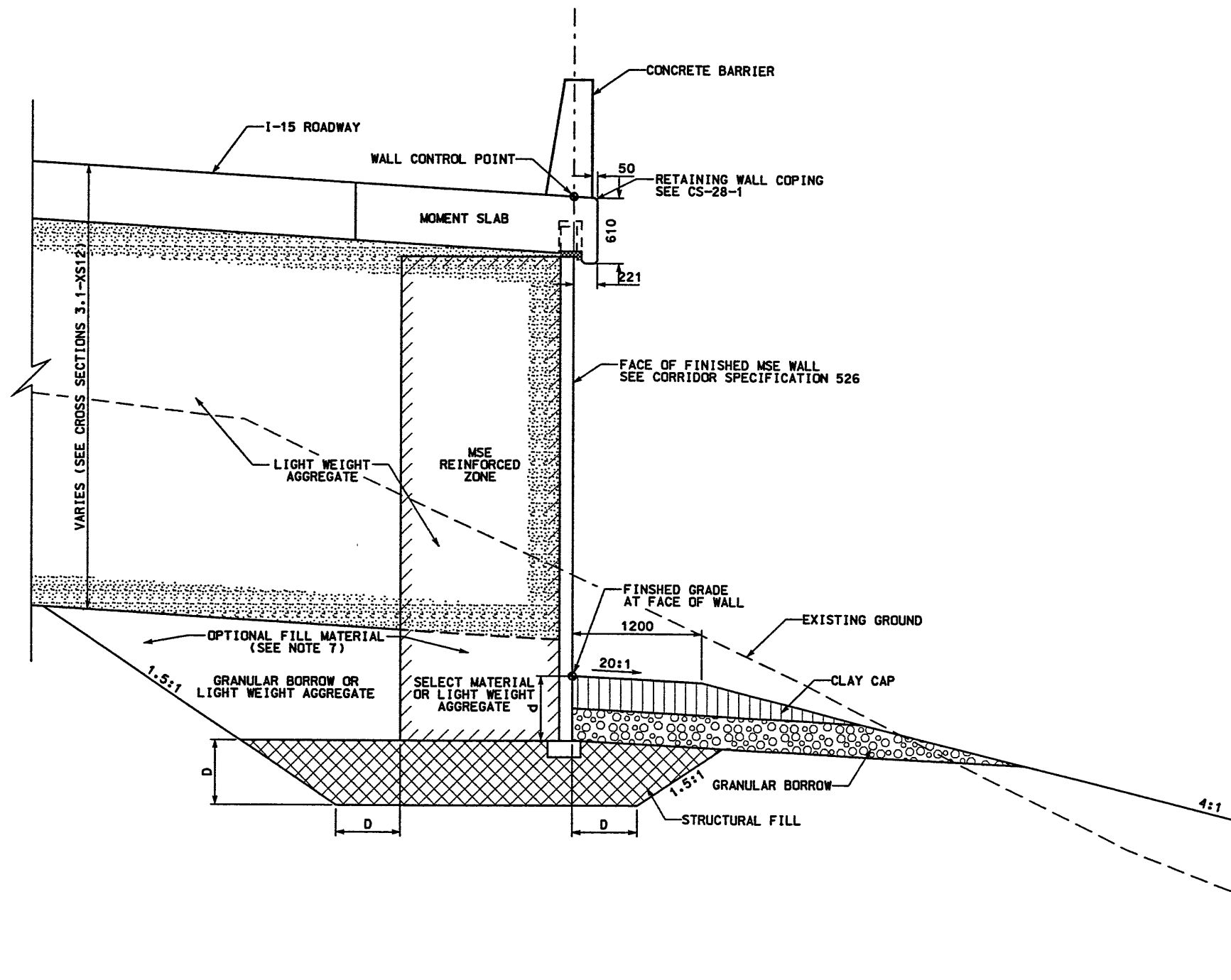

DETAIL F
5+047.43 TO ± 5+068

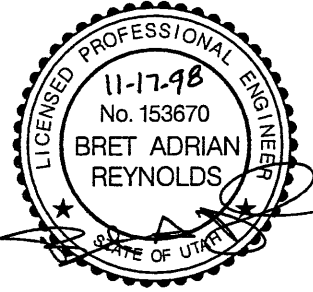

WASATCH CONSTRUCTORS
DEC 02 1998
RELEASED FOR CONSTRUCTION

APPROVED FOR CONSTRUCTION		DESCRIPTION	
NO.	DATE	NO.	DATE
△	11/20/98	△	11/20/98
△	11/20/98	△	11/20/98
△	11/20/98	△	11/20/98
△	11/20/98	△	11/20/98
UTAH DEPARTMENT OF TRANSPORTATION		WBS NO. 3113403	
MK CENTENNIAL		DESIGN CHECK C/J/D 7/01/98	
SVERDRUP/DE LEUW		DRAWN CHECK C/J/D 7/01/98	
Bret A. Reynolds		PROJECT DESIGN ENGINEER	
DATE 11/20/98		DATE 11/20/98	
Ratidie L. Ross		PROJECT MANAGER	
APPROVED 11/20/98		DATE 11/20/98	
PROJECT NUMBER #SP-15-7(135)296		COUNT. / /	
I-15 CORRIDOR RECONSTRUCTION		SALT LAKE COUNTY	
WALL DETAIL R-350-17		DWG. NO. 3.1R-350-17.7	
SECTION 3.1		SHT. 7 OF 15	
REF.			

Username: c:\adgn\l... Date: 17-NOV-1998 Time: 10:45

RETAINING WALL DETAILS

WALL R-350-17
(1-STAGE MSE WALL)
NTS

NOTES:

- 1) SEE CORRIDOR STANDARD SPECIFICATION 221 FOR BENCHING AND SPECIAL EXCAVATION REQUIREMENTS WHERE GROUNDWATER IS EXPECTED AT OR ABOVE THE REQUIRED EXCAVATION.
- 2) FOUNDATION BEARING MATERIALS SHALL BE OBSERVED BY THE GEOTECHNICAL ENGINEER DURING SITE PREPARATION. ANY UNDESIRABLE MATERIALS SHALL BE REMOVED AND REPLACED IN ORDER TO ACHIEVE ACCEPTABLE CONDITIONS AT THE BASE OF THE WALL.
- 3) LIGHT WEIGHT AGGREGATE (LWA) AS DEFINED IN CORRIDOR STANDARD SPECIFICATION 220B SHALL BE BLAST FURNACE SLAG (90 TO 95 PCF) OR APPROVED EQUIVALENT.
- 4) SEE GRADING SHEET 3.1-GR6 FOR LIMITS OF LWA AND CROSS SECTION SHEET 3.1-XS12 FOR DEPTH TO BOTTOM OF LWA.
- 5) SELECT MATERIAL FOR MSE REINFORCED ZONE SHALL BE AS DEFINED IN CORRIDOR STANDARD SPECIFICATION 525.
- 6) OVEREXCAVATE EXISTING SOILS TO DEPTH (D) BENEATH WALL AS SHOWN. LWA FILL SHALL BE USED WITH D = 1.0m MINIMUM. FOR D DIMENSION SEE VSL DRAWINGS.
- 7) CONSTRUCT CLAY CAP PER CORRIDOR STANDARD SPECIFICATION 526 (0.3m THICK).
- 8) SEE VSL DRAWINGS FOR EMBEDMENT DEPTH (d).

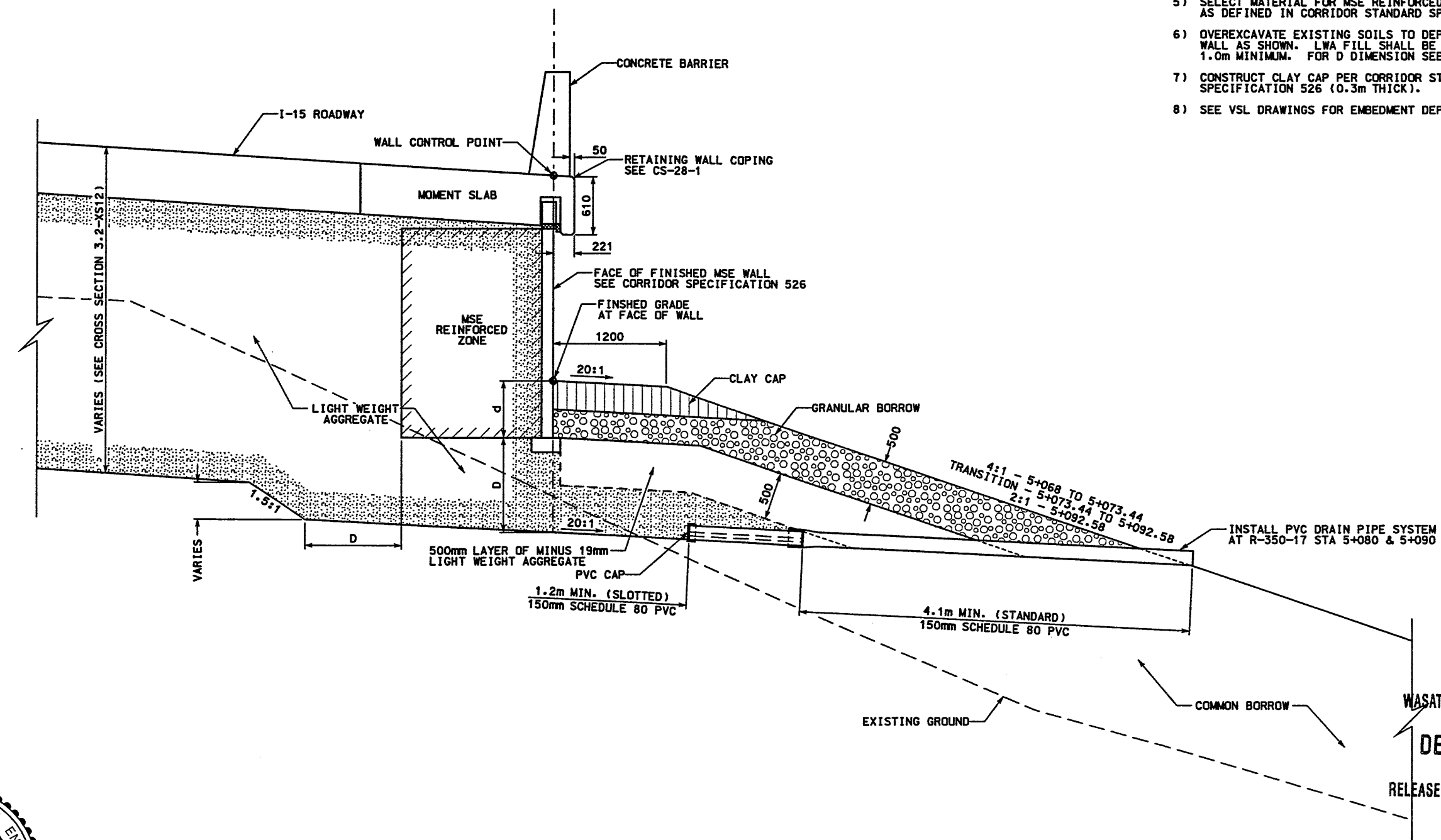

DETAIL G
± 5+068 TO 5+092.58



WASATCH CONSTRUCTORS
DEC 0 2 1998
RELEASED FOR CONSTRUCTION

APPROVED FOR CONSTRUCTION		DESCRIPTION	
NO.	DATE	NO.	DATE
1	11/20/98	1	11/20/98
2	11/20/98	2	11/20/98
3	11/20/98	3	11/20/98
4	11/20/98	4	11/20/98

UTAH DEPARTMENT OF TRANSPORTATION			
MK CENTENNIAL			
SYVERDRUP/DE LEUW			
DESIGN MGR	CHECK	DESIGN MGR	CHECK
Bret A. Reynolds	7/01/98	Bret A. Reynolds	7/01/98
PROJECT DESIGN ENGINEER	DATE	PROJECT DESIGN ENGINEER	DATE
Randall L. Robb	7/01/98	Randall L. Robb	7/01/98
PROJECT MANAGER	DATE	PROJECT MANAGER	DATE

I-15 CORRIDOR RECONSTRUCTION	
WALL DETAIL R-350-17	SECTION 3.1
PROJECT NUMBER	#SP-15-7(135)296
COUNTY	SALT LAKE
DWG. NO.	3.1R-350-17.8
SHT.	8 OF 15
REF.	

APPROVED FOR CONSTRUCTION		
NO.	DATE	DESCRIPTION
1	11-18-98	RELEASE FOR CONSTRUCTION

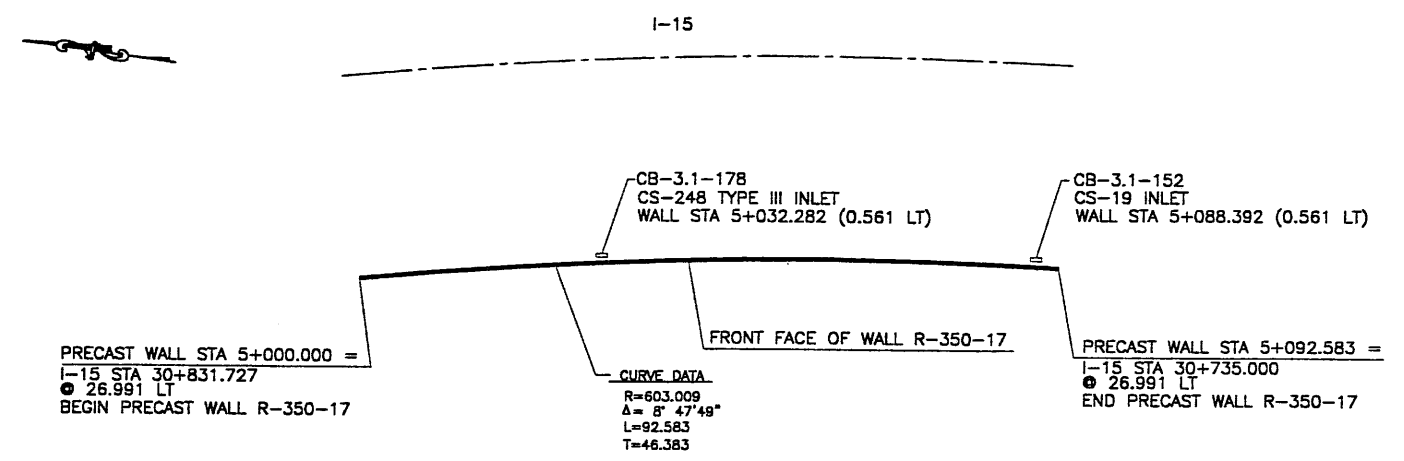

PLAN VIEW WALL "R-350-17"

SCALE: 1=250 (FULL SIZE)
SCALE: 1=500 (HALF SIZE)

STANDARD BACKFILL	SCORIA
ANGLE OF INTERNAL FRICTION (SELECT) = 34°	ANGLE OF INTERNAL FRICTION (SELECT) = 26°
ANGLE OF INTERNAL FRICTION (BASE) = 34°	ANGLE OF INTERNAL FRICTION (BASE) = 26°
ANGLE OF INTERNAL FRICTION (RANDOM) = 34°	ANGLE OF INTERNAL FRICTION (RANDOM) = 26°
UNIT WEIGHT BACKFILL = 135 PCF. (21.2 KN/M ³)	UNIT WEIGHT BACKFILL = 52 TO 60 PCF. (8.2 TO 9.4 KN/M ³)
TRAFFIC SURCHARGE = 250 PSF (12 KPa)	TRAFFIC SURCHARGE = 250 PSF (12 KPa)
SEISMIC ACCELERATION COFF. = 0.27g (TYP)	SEISMIC ACCELERATION COFF. = 0.27g (50 YR)
	SEISMIC ACCELERATION COFF. = 0.68g (250 YR)

DESIGN CRITERIA
SAFETY FACTOR (OVERTURNING) = 2.0
SAFETY FACTOR (SLIDING) = 1.5
SAFETY FACTOR (PULLOUT) = 1.5
DESIGN LIFE = 75 YEARS

RETAINED EARTH INDEX	
RE-1	PLAN PRECAST FACE WALL R-350-17, NOTES & DESIGN CRITERIA
RE-2	TYPICAL CROSS SECTION
RE-3	TYPICAL CROSS SECTION
RE-4	TYPICAL CROSS SECTION
RE-5	TYPICAL CROSS SECTION
RE-6	ELEVATION PRECAST WALL "R-350-17"
RE-7	SPECIAL PANEL DETAILS

WASATCH CONSTRUCTORS
DEC 0 2 1998
RELEASED FOR CONSTRUCTION

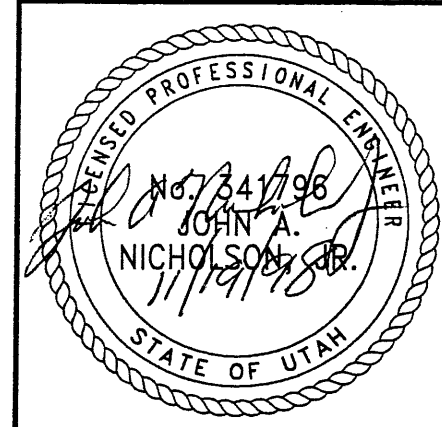

CERTIFIED FOR INTERNAL STABILITY OF RETAINED EARTH™ STRUCTURES ONLY. EXTERNAL STABILITY, INCLUDING BUT NOT LIMITED TO FOUNDATION AND SLOPE STABILITY, IS THE RESPONSIBILITY OF THE OWNER. DESIGN IS BASED ON THE ASSUMPTION THAT THE MATERIAL WITHIN THE RETAINED EARTH™ MASS, METHODS OF CONSTRUCTION, AND QUALITY OF PREFABRICATED MATERIALS CONFORM TO THE MANUFACTURER'S SPECIFICATION.

METRIC

RETAINED EARTH™ WALLS
PLAN VIEW PRECAST WALL "R-350-17"
UTAH I-15 RECONSTRUCTION
SALT LAKE COUNTY, UTAH
UTAH DEPARTMENT OF TRANSP.

VSL CORPORATION
2840 Peachtree Dunwoody Rd., Suite 200
Atlanta, GA 30328
Telephone: (404) 781-6272
Fac: (404) 781-6659

ATLANTA, GA / DALLAS, TX / RALEIGH, NC (CORPORATE OFFICE)
BIRMINGHAM, AL / SAN JOSE, CA / SPRINGFIELD, VA

DES. 11-02-98 JN
DRN. 11-02-98 RSW
CHK. 11-02-98 JN
RETAINED EARTH™

DWG. NO. 3.1R-350-17.9
JOB NO. 239-0007
SHT. NO. RE-1

NO. DATE DESCRIPTION
11-18-98 RELEASE FOR CONSTRUCTION

NO. DATE REVISION BY CHK

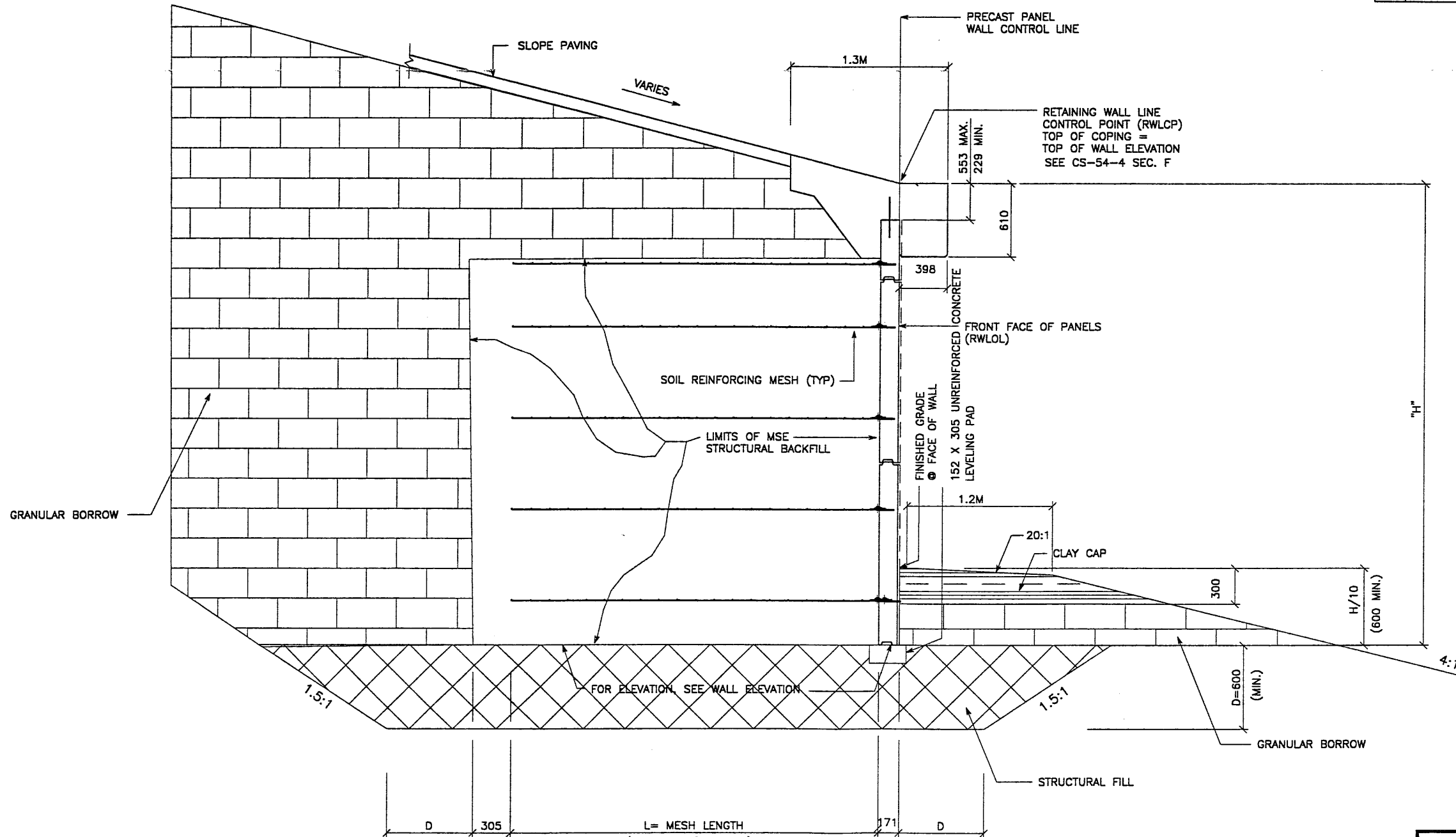

TYPICAL CROSS SECTION - STA 5+000.00 TO STA 5+022.45
 (SEE DWG. NO. 3.1R-350-17.2 FOR ADDITIONAL INFORMATION)
 SCALE: 1:20 (FULL SIZE)
 SCALE: 1:40 (HALF SIZE)

APPROVED FOR CONSTRUCTION		
NO.	DATE	DESCRIPTION
1	11-18-98	RELEASE FOR CONSTRUCTION

DES.	DRN.	CHK.	NO.	DATE	REVISION	BY
JN	RSW	JN				
JN	RSW	JN				

VSL CORPORATION
 2840 Plaza Place, Suite 200
 Raleigh, NC 27603
 Tel: (919) 781-6272
 Fax: (919) 781-4869

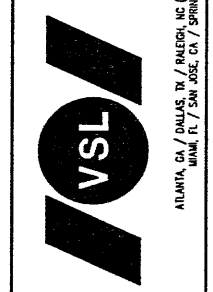

VSL Corporation hereby certifies that the design and construction of the structure shown on this plan, in accordance with the specifications and standards set forth herein, is the responsibility of the engineer. The use of this plan as a guide for construction or as a part of any other project, or any other use, is the responsibility of the user. VSL Corporation and its employees accept no liability for any errors or omissions in this plan, or for any other use of this plan. ANY OTHER USE IS AT THE USER'S SOLE RISK AND LIABILITY. THEREFORE, THE USER SHALL BE RESPONSIBLE FOR OBTAINING ALL NECESSARY PERMITS AND APPROVALS FROM THE APPROPRIATE AGENCIES.

WASATCH CONSTRUCTORS
DEC 0 2 1998
RELEASED FOR CONSTRUCTION

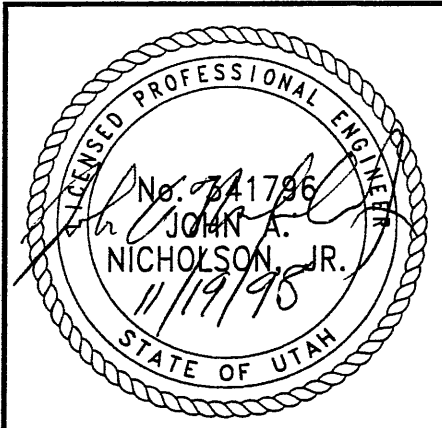

RETAINED EARTH™ WALLS
 WIRE FACED WALL "R-350-17"
 TYPICAL CROSS SECTION
 UTAH I-15 INTERCHANGE
 SALT LAKE COUNTY, UTAH
 UTAH DEPARTMENT OF TRANSP.

DWG. NO.	2.2R-350-17.10
JOB NO.	239-0007
SHT. NO.	RE-2

METRIC

CERTIFIED FOR INTERNAL STABILITY OF RETAINED EARTH™ STRUCTURES ONLY. EXTERNAL STABILITY, INCLUDING BUT NOT LIMITED TO FOUNDATION AND SLOPE STABILITY, IS THE RESPONSIBILITY OF THE OWNER. DESIGN IS BASED ON THE ASSUMPTION THAT THE MATERIAL WITHIN THE RETAINED EARTH™ MASS, METHODS OF CONSTRUCTION, AND QUALITY OF PREFABRICATED MATERIALS CONFORM TO THE MANUFACTURER'S SPECIFICATION.

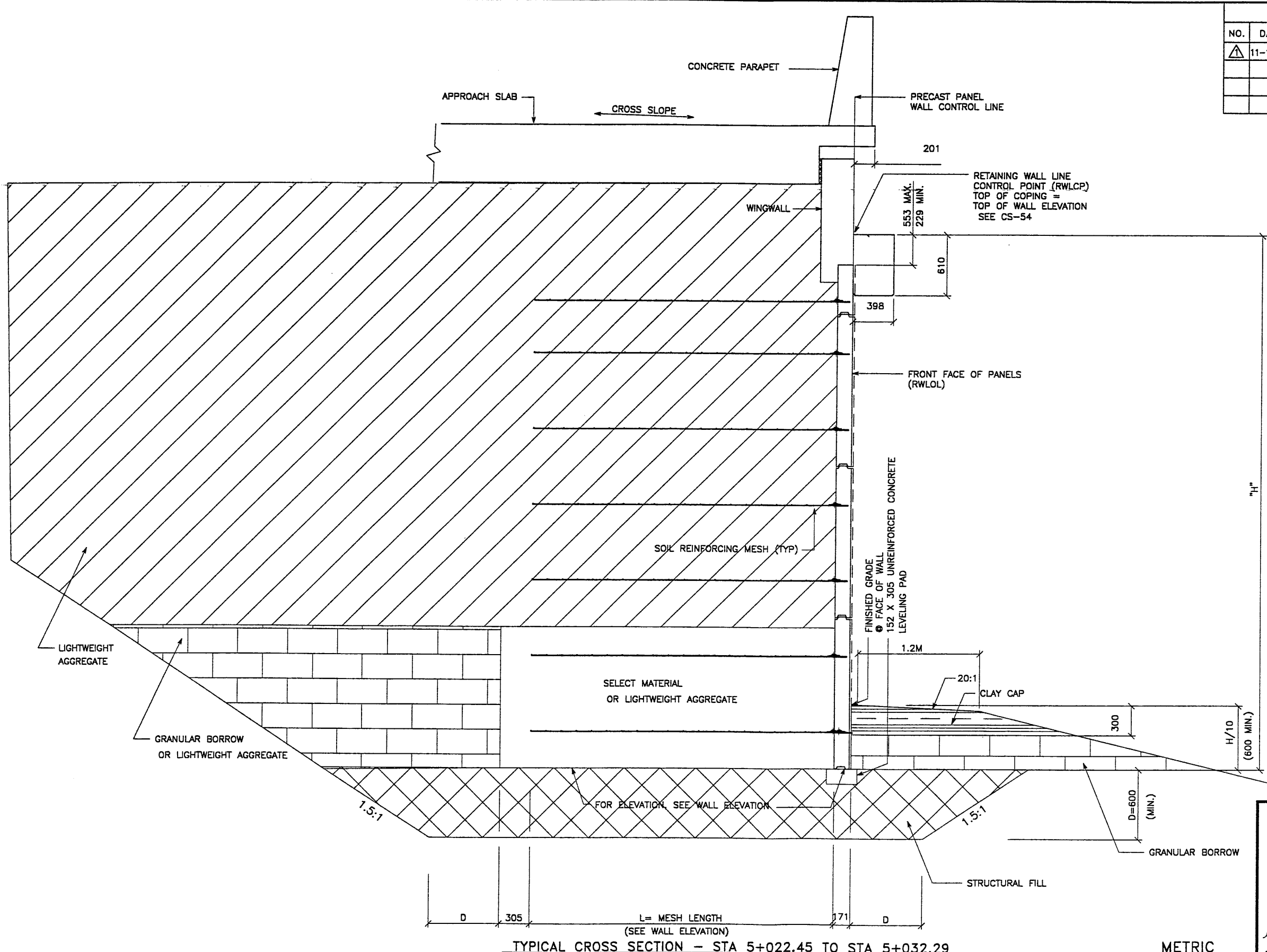

APPROVED FOR CONSTRUCTION		
NO.	DATE	DESCRIPTION
1	11-18-98	RELEASE FOR CONSTRUCTION

DES.	DRN.	CHK.	RETAINED EARTH™	NO.	DATE	BY	CHK
JN	RSW	JN	VSL				

VSL CORPORATION
2840 Plaza Place, Suite 200
Raleigh, NC 27612
Telephone: (919) 781-8272
Fax: (919) 781-6859

ALUMINUM / BRASS / PLYWOOD (SEPARATE OFFICE)
WALK, FL / SAN JOSE, CA / SPRINGFIELD, VA

VSL

WASATCH CONSTRUCTORS
DEC 02 1998
RELEASED FOR CONSTRUCTION

RETAINED EARTH™ WALLS
WIRE FACED WALL "R-350-17"
TYPICAL CROSS SECTION
UTAH I-15 INTERCHANGE
SALT LAKE COUNTY, UTAH
UTAH DEPARTMENT OF TRANSP.

PROFESSIONAL ENGINEER
No. 341796
JOHN A. NICHOLSON, JR.
11/17/98
STATE OF UTAH

DWG. NO. 2.2R-350-17.11
JOB NO. 239-0007
SHT. NO. RE-3

TYPICAL CROSS SECTION - STA 5+022.45 TO STA 5+032.29

(SEE DWG. NO. 3.1R-350-17.3 FOR ADDITIONAL INFORMATION)
(SEE DWG. NO. 3.1R-350-17.4 FOR ADDITIONAL INFORMATION)
SCALE: 1:20 (FULL SIZE)
SCALE: 1:40 (HALF SIZE)

CERTIFIED FOR INTERNAL STABILITY OF RETAINED EARTH™ STRUCTURES ONLY.
EXTERNAL STABILITY, INCLUDING BUT NOT LIMITED TO FOUNDATION AND SLOPE
STABILITY, IS THE RESPONSIBILITY OF THE OWNER. DESIGN IS BASED ON THE
ASSUMPTION THAT THE MATERIAL WITHIN THE RETAINED EARTH™ MASS, METHODS
OF CONSTRUCTION, AND QUALITY OF PREFABRICATED MATERIALS CONFORM TO
THE MANUFACTURER'S SPECIFICATION.

METRIC

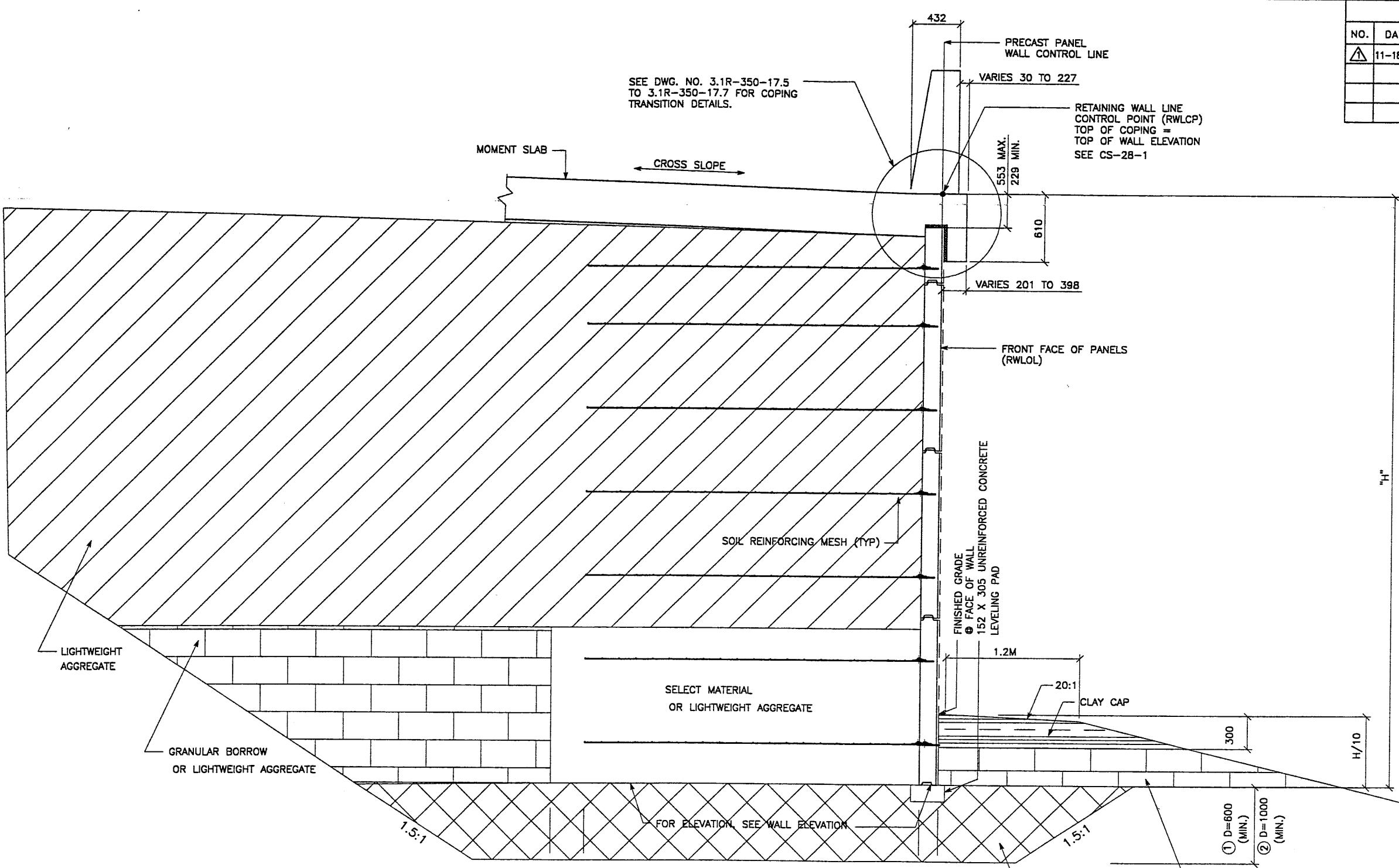

APPROVED FOR CONSTRUCTION		
NO.	DATE	DESCRIPTION
▲	11-18-98	RELEASE FOR CONSTRUCTION

NO.	DATE	REVISION	BY	CHK

VSL CORPORATION
 2800 Pines Plaza, Suite 200
 Raleigh, NC 27612 781-8272
 Telephone: (919) 781-8272
 Fax: (919) 781-8869

ATLANTA, GA / DALLAS, TX / DENVER, CO (CORPORATE OFFICE)
 MIAMI, FL / SAN JOSE, CA / SPANISH WOOD, VA

VSL Corporation (VSL) is a strict liability professional engineer. The information contained herein is for informational purposes only and is not intended to be used for any purpose other than that for which it was prepared. VSL disclaims any liability for errors, omissions, or any other consequences arising from the use of this information.

WASATCH CONSTRUCTORS

DEC 02 1998

RELEASED FOR CONSTRUCTION

TYPICAL CROSS SECTION - STA 5+032.29 TO STA 5+068.000

(SEE DWG. NO. 3.1R-350-17.5 FOR ADDITIONAL INFORMATION)
 (SEE DWG. NO. 3.1R-350-17.6 FOR ADDITIONAL INFORMATION)
 (SEE DWG. NO. 3.1R-350-17.7 FOR ADDITIONAL INFORMATION)

SCALE: 1:20 (FULL SIZE)
 SCALE: 1:40 (HALF SIZE)

- ① STA. 5+032 TO STA. 5+047
- ② STA. 5+047 TO STA. 5+068

METRIC

CERTIFIED FOR INTERNAL STABILITY OF RETAINED EARTH™ STRUCTURES ONLY. EXTERNAL STABILITY, INCLUDING BUT NOT LIMITED TO FOUNDATION AND SLOPE STABILITY, IS THE RESPONSIBILITY OF THE OWNER. DESIGN IS BASED ON THE ASSUMPTION THAT THE MATERIAL WITHIN THE RETAINED EARTH™ MASS, METHODS OF CONSTRUCTION, AND QUALITY OF PREFABRICATED MATERIALS CONFORM TO THE MANUFACTURER'S SPECIFICATION.

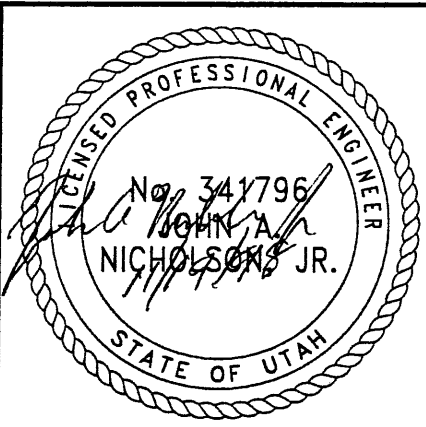

RETAINED EARTH™ WALLS
 WIRE FACED WALL "R-350-17"
 TYPICAL CROSS SECTION
 UTAH I-15 INTERCHANGE
 SALT LAKE COUNTY, UTAH
 UTAH DEPARTMENT OF TRANSP.

DWG. NO.	2.2R-350-17.12
JOB NO.	239-0007
SHT. NO.	RE-4

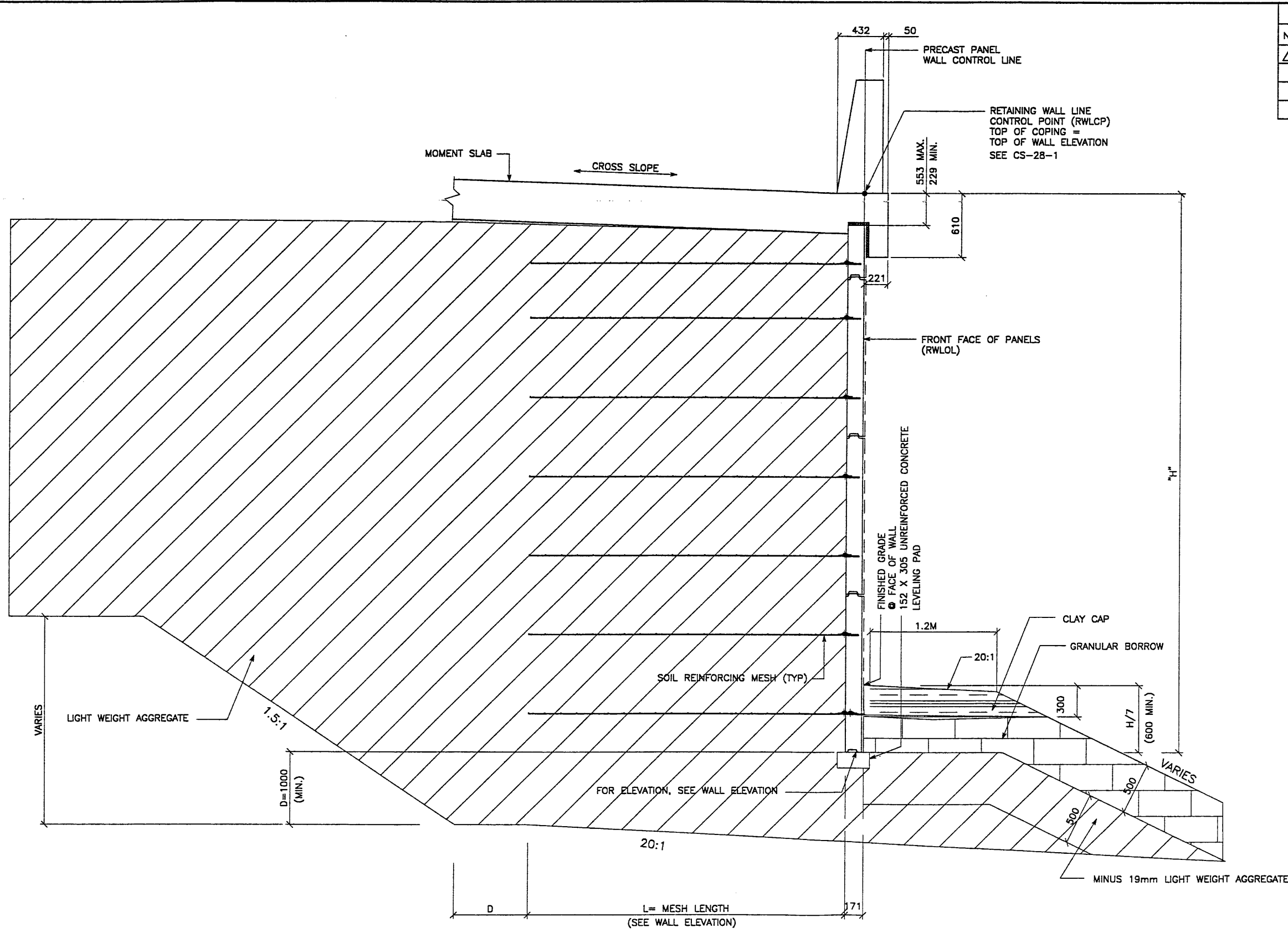

TYPICAL CROSS SECTION - STA 5+068 TO STA 5+092.580
 (SEE DWG. NO. 3.1R-350-17.8 FOR ADDITIONAL INFORMATION)
 SCALE: 1:20 (FULL SIZE)
 SCALE: 1:40 (HALF SIZE)

CERTIFIED FOR INTERNAL STABILITY OF RETAINED EARTH™ STRUCTURES ONLY. EXTERNAL STABILITY, INCLUDING BUT NOT LIMITED TO FOUNDATION AND SLOPE STABILITY, IS THE RESPONSIBILITY OF THE OWNER. DESIGN IS BASED ON THE ASSUMPTION THAT THE MATERIAL WITHIN THE RETAINED EARTH™ MASS, METHODS OF CONSTRUCTION, AND QUALITY OF PREFABRICATED MATERIALS CONFORM TO THE MANUFACTURER'S SPECIFICATION.

METRIC

APPROVED FOR CONSTRUCTION		
NO.	DATE	DESCRIPTION
△	11-18-98	RELEASE FOR CONSTRUCTION <i>SW</i>

NO.	DATE	REVISION

DES. 11-02-98 JN
 DRN. 11-02-98 RSW
 CHK. 11-02-98 JN

VSL CORPORATION
 2840 Plaza Place, Suite 200
 Raleigh, NC 27612
 Telephone: (919) 781-6272
 Fax: (919) 781-6889

ALABAMA, GA / DANVILLE, VA (CORPORATE OFFICE)
 MINNAPOLIS, MN / SAN JOSE, CA / SPRINGFIELD, VA

VSL Corporation (VSL) claims a strict proprietary right in its Retained Earth™ System and related information and methods. Such information is either a trade secret or, in part, or any other information that is not generally known and that is not prepared or derived from independent work. VSL disclaims any liability therefor.

WASATCH CONSTRUCTORS
DEC 0 2 1998
RELEASED FOR CONSTRUCTION

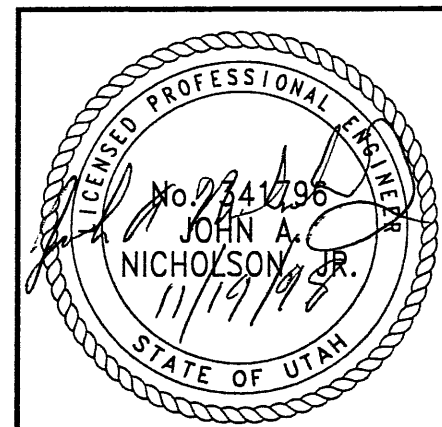

RETAINED EARTH™ WALLS
 WIRE FACED WALL "R-350-17"
 TYPICAL CROSS SECTION
 UTAH I-15 INTERCHANGE
 SALT LAKE COUNTY, UTAH
 UTAH DEPARTMENT OF TRANSP.

DWG. NO.	3.1R-350-17.13
JOB NO.	239-0007
SHT. NO.	RE-5

ICE (X-UTAH.DWG) XR '007\1998\9WSERIES\9W-11\9W-09 H:\RE_EARTH\PROJECT\2 08-26-99 FINAL P'

END WALL R-350-17
WALL STA 5+000.000 =
I-15 STA 30+831.727
● 26.991 LT
NOMINAL PANEL FACE (RWLOL)

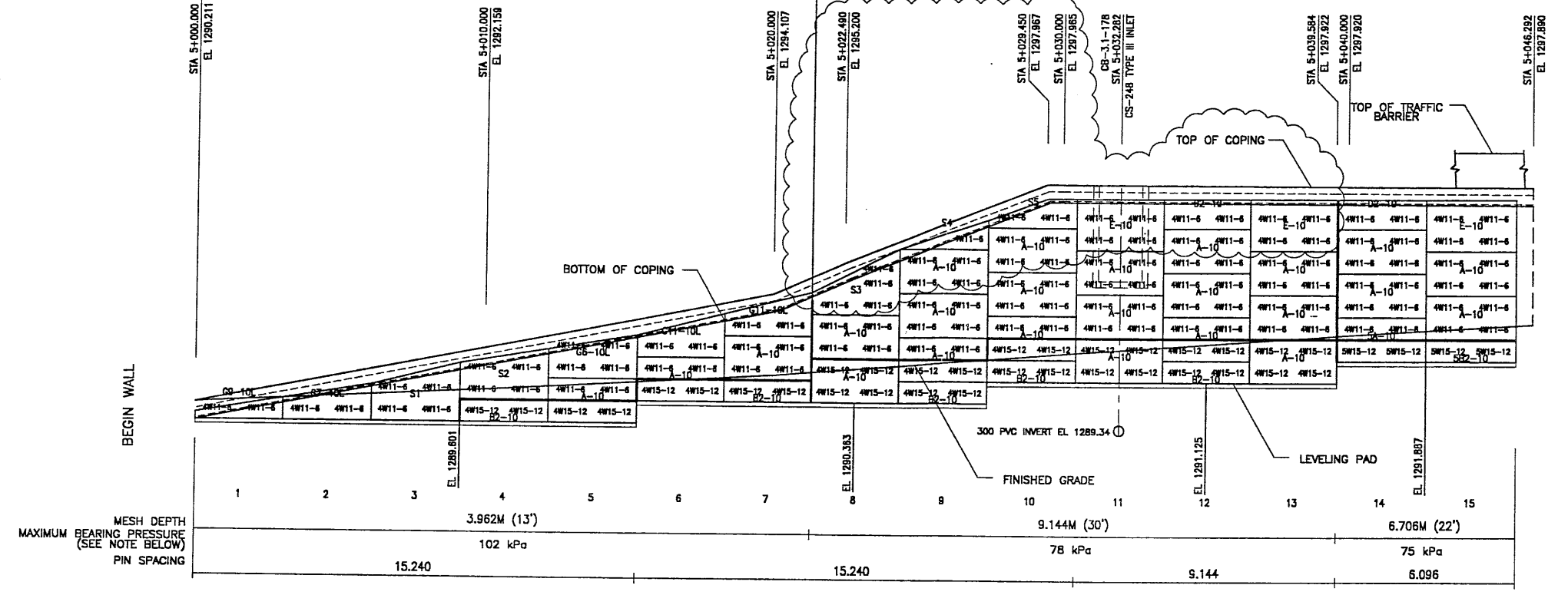

APPROVED FOR CONSTRUCTION		
NO.	DATE	DESCRIPTION
11-18-98		RELEASE FOR CONSTRUCTION
08-26-99		REVISED S&L

DES.	DRN.	CHK.	DATE	NO.	REVISION	BY
08-26-99	JN					
08-26-99	DSW					
08-26-99	JN					

VSL CORPORATION
2840 Fazio Place, Suite 200
Farmingdale, NY 11737
Tel: (609) 781-9272
Fax: (609) 781-6689

ATLANTA, GA / DALLAS, TX / FREDERICK, MD (CORPORATE OFFICE)
MIAMI, FL / SAN JOSE, CA / SPRINGFIELD, VA

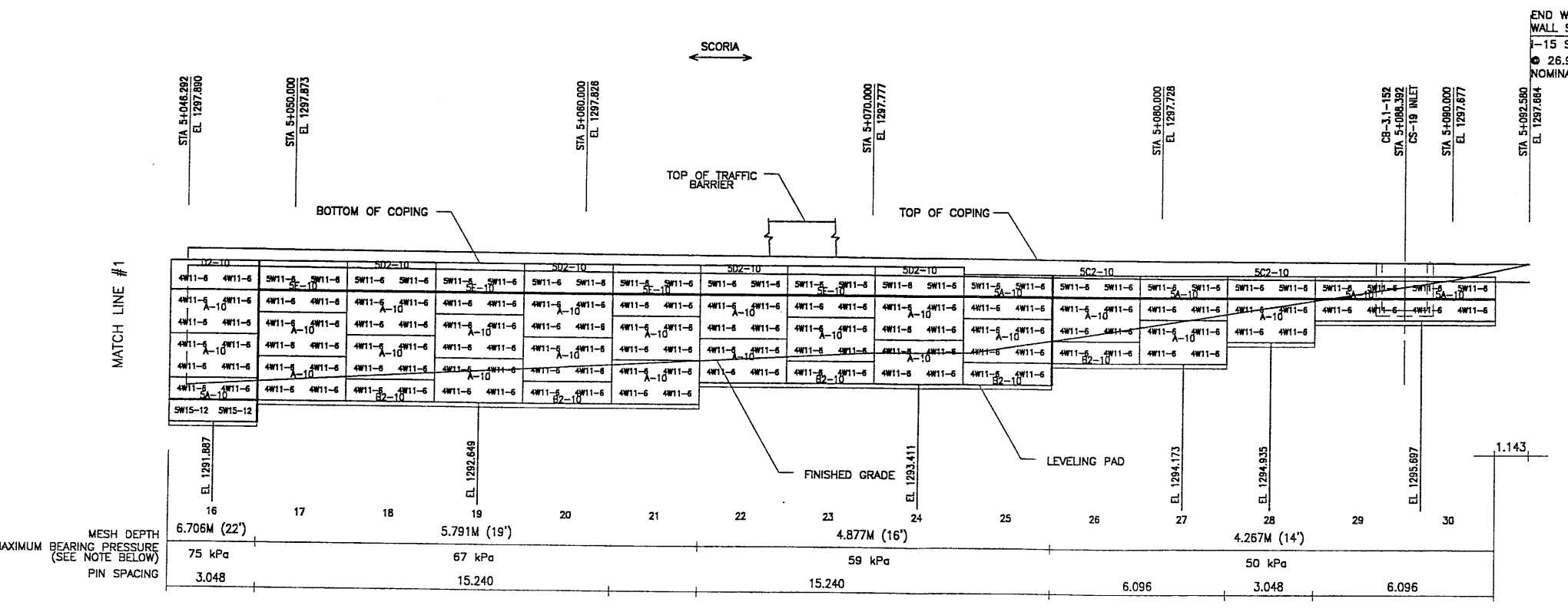

END WALL R-350-17
WALL STA 5+092.580 =
I-15 STA 30+735.000
● 26.991 LT
NOMINAL PANEL FACE (RWLOL)

WASATCH CONSTRUCTORS
FEB 28 2000
RELEASED FOR CONSTRUCTION

ELEVATION PRECAST WALL R-350-17

(FRONT FACE SHOWN) SCALE 1:100 (FULL SIZE)
SCALE 1:200 (HALF SIZE)
(TOTAL SURFACE AREA OF PANELS = 360.63 SM)

NOTE:
THE INDICATED MAXIMUM BEARING PRESSURE
AT FINAL STAGE FOR STATIC LOAD CONDITION.

METRIC

CERTIFIED FOR INTERNAL STABILITY OF RETAINED EARTH™ STRUCTURES ONLY.
EXTERNAL STABILITY, INCLUDING BUT NOT LIMITED TO FOUNDATION AND SLOPE
STABILITY, IS THE RESPONSIBILITY OF THE OWNER. DESIGN IS BASED ON THE
ASSUMPTION THAT THE MATERIAL WITHIN THE RETAINED EARTH™ MASS, METHODS
OF CONSTRUCTION, AND QUALITY OF PREFABRICATED MATERIALS CONFORM TO
THE MANUFACTURER'S SPECIFICATION.

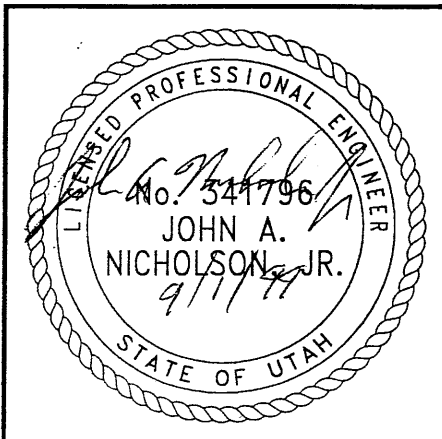

RETAINED EARTH™ WALLS
PRECAST WALL "R-350-17"
UTAH I-15 RECONSTRUCTION
SALT LAKE COUNTY, UTAH
UTAH DEPARTMENT OF TRANSP.

DWG. NO.	3.1R-350-17.14
JOB NO.	239-0007
SHT. NO.	RE-6

RFC After Final Approval

007\1998\9WSERIES\9W-11\9W-09

H:\RE_EARTH\PROJECT\

T 11-18-98

FINAL

END WALL R-350-17
WALL STA 5+000.000 =
I-15 STA 30+831.727
● 26.991 LT
NOMINAL PANEL FACE (RWLOL)

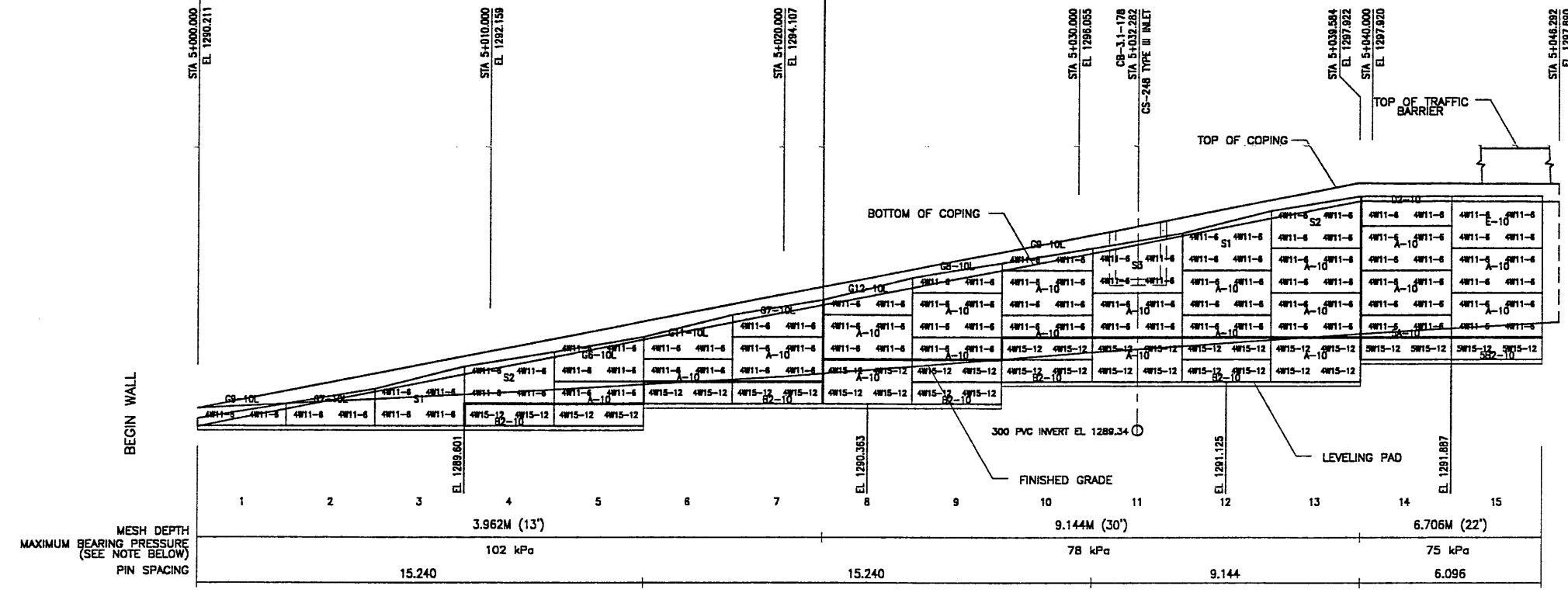

END WALL R-350-17
WALL STA 5+092.580 =
I-15 STA 30+735.000
● 26.991 LT
NOMINAL PANEL FACE (RWLOL)

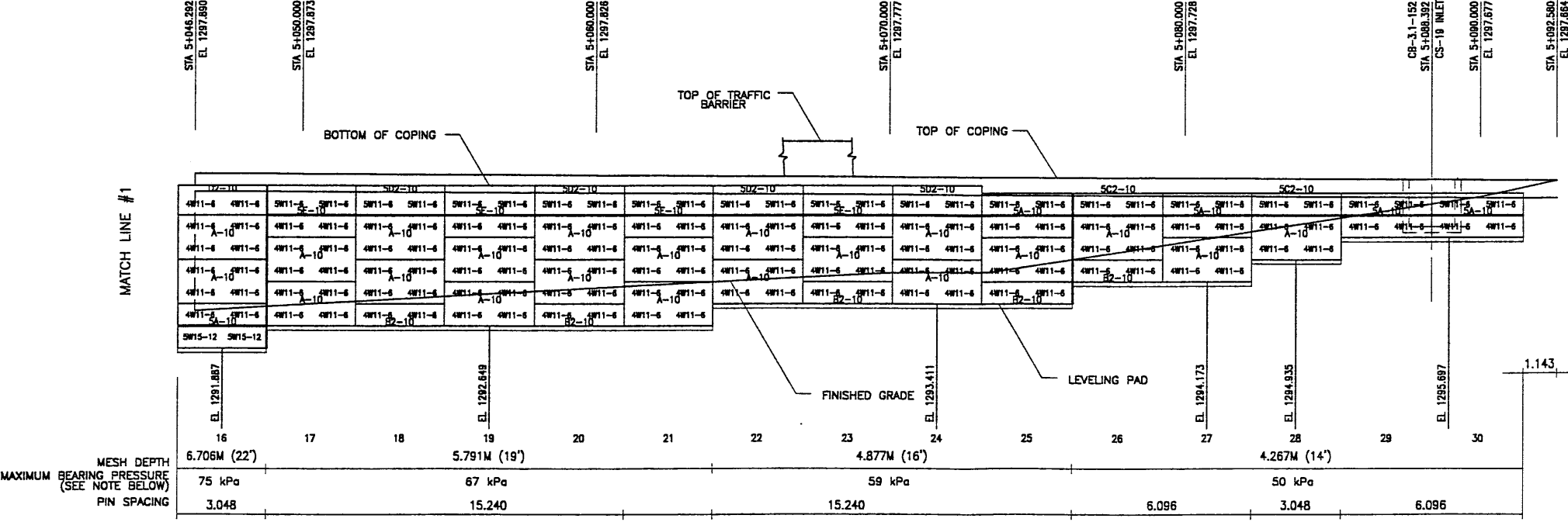

ELEVATION PRECAST WALL R-350-17

(FRONT FACE SHOWN) SCALE 1:100 (FULL SIZE)
(TOTAL SURFACE AREA OF PANELS = 340.88 SM) SCALE 1:200 (HALF SIZE)

CERTIFIED FOR INTERNAL STABILITY OF RETAINED EARTH™ STRUCTURES ONLY. EXTERNAL STABILITY, INCLUDING BUT NOT LIMITED TO FOUNDATION AND SLOPE STABILITY, IS THE RESPONSIBILITY OF THE OWNER. DESIGN IS BASED ON THE ASSUMPTION THAT THE MATERIAL WITHIN THE RETAINED EARTH™ MASS, METHODS OF CONSTRUCTION, AND QUALITY OF PREFABRICATED MATERIALS CONFORM TO THE MANUFACTURER'S SPECIFICATION.

APPROVED FOR CONSTRUCTION		
NO.	DATE	DESCRIPTION
▲ 11-18-98		RELEASE FOR CONSTRUCTION

DES.	DRN.	CHK.	NO.	DATE	REVISION	BY
DES. 11-03-98	JN					
DRN. 11-03-98	RSW					
CHK. 11-03-98	JN					

VSL CORPORATION
2840 Plaza Place, Suite 200
Raleigh, NC 27612
Telephone: (919) 781-9272
Fac: (919) 781-9959

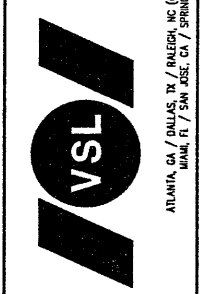

WASATCH CONSTRUCTORS
DEC 02 1998

RELEASED FOR CONSTRUCTION
RETAINED EARTH™ WALLS
PRECAST WALL "R-350-17"
UTAH I-15 RECONSTRUCTION
SALT LAKE COUNTY, UTAH
UTAH DEPARTMENT OF TRANSP.

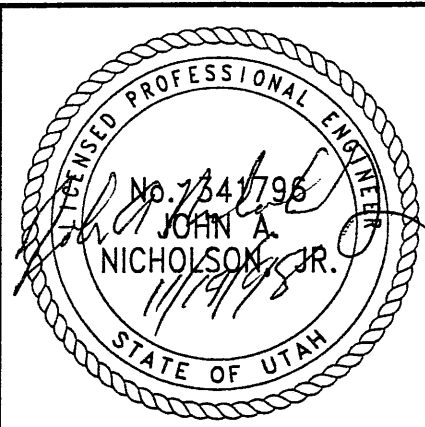

DWG. NO.	2.7R-350-17.14
JOB NO.	239-0007
SHT. NO.	RE-6

SHT 14 OF 15

NCE (X-UTAH.DWG)
X
"S\13-117\RE-1"
H:\RE_EARTH\PROJECT\239-0007\1997\1"
FINAL PLOT 08-26-99

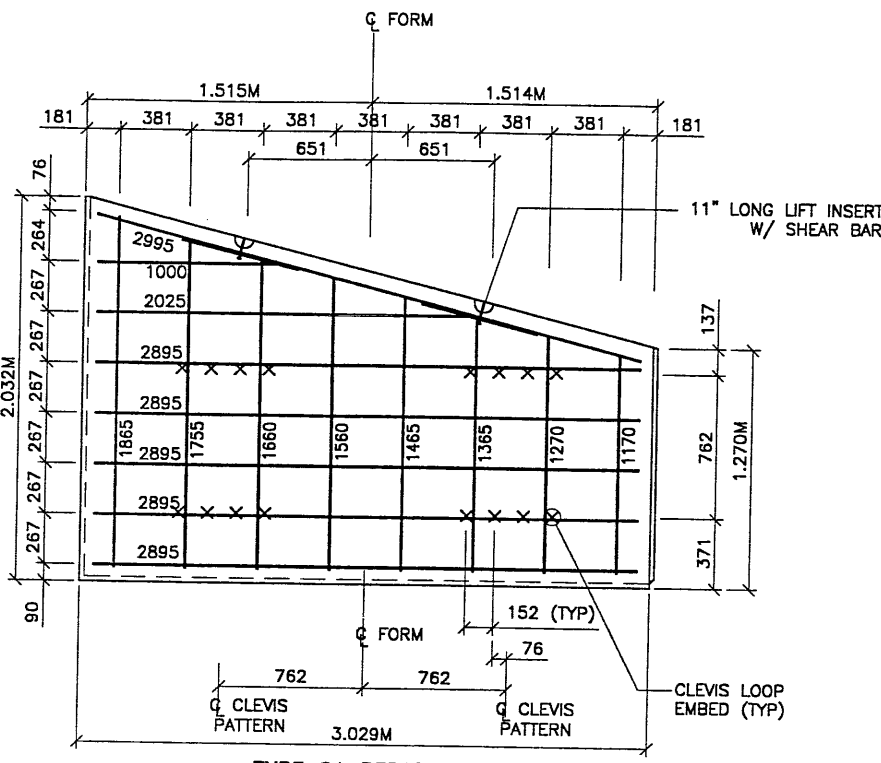

TYPE S1 REBAR
(AREA = 5.03 SQ.M)

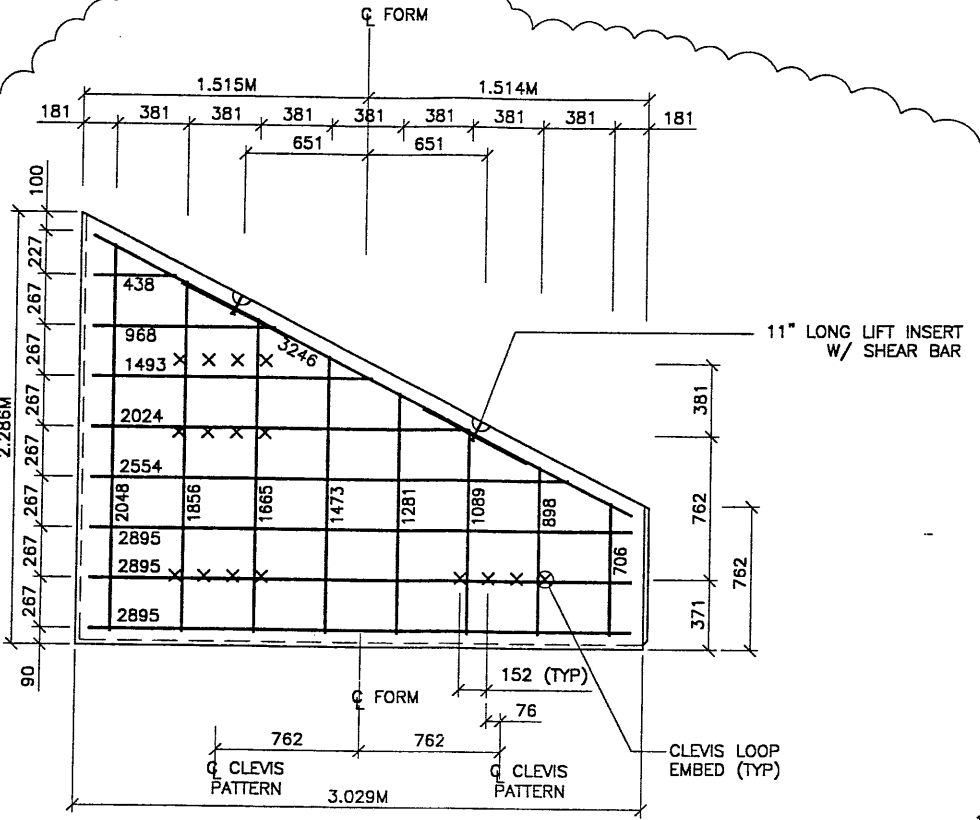

TYPE S3 REBAR
(AREA = 4.65 SQ.M)

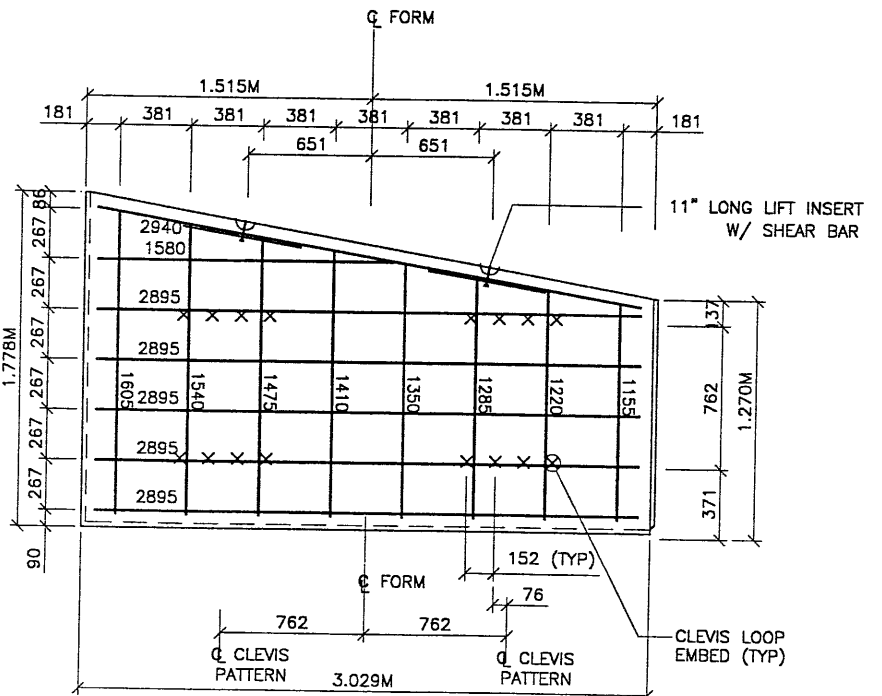

TYPE S2 REBAR
(AREA = 4.65 SQ.M)

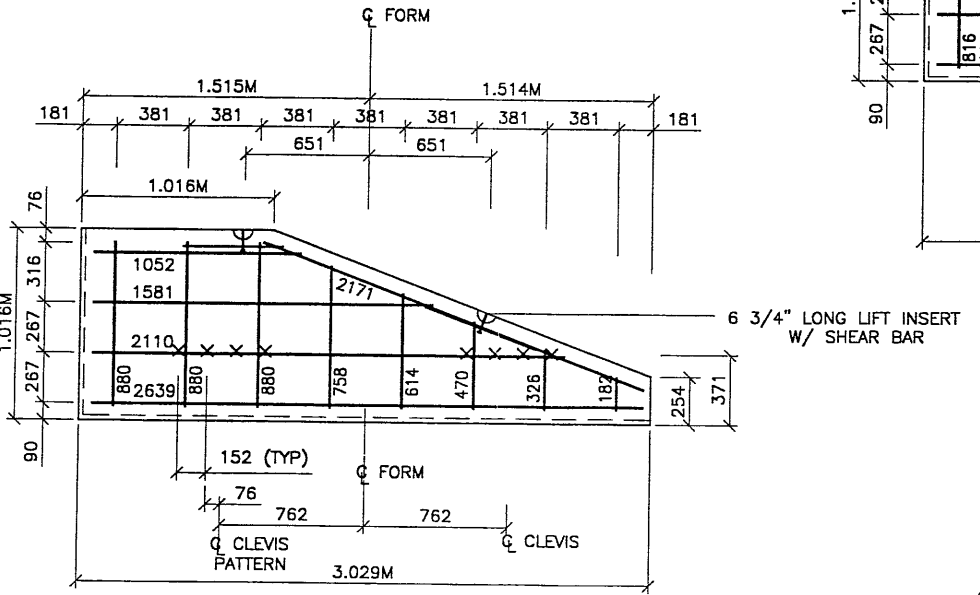

TYPE S5 REBAR
(AREA = 2.32 SQ.M)

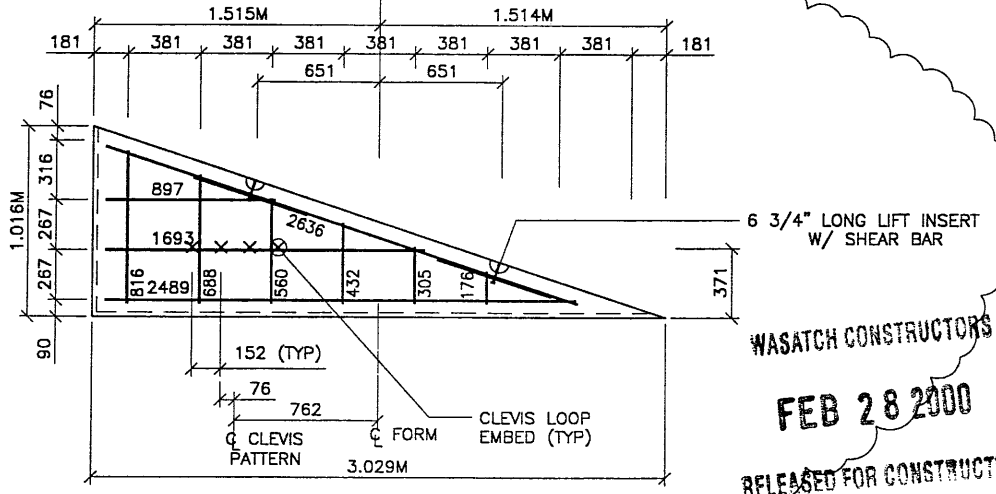

TYPE S4 REBAR
(AREA = 1.55 SQ.M)

APPROVED FOR CONSTRUCTION		
NO.	DATE	DESCRIPTION
1	11-18-98	RELEASE FOR CONSTRUCTION
2	08-26-99	REVISED SPECIAL PANELS

- PANEL REINFORCEMENT NOTES:
- PANELS ARE SHOWN BACK FACE.
 - HORIZONTAL REINFORCEMENT SHALL HAVE 50 mm MINIMUM COVER TO THE BACK FACE.
 - ALL REINFORCEMENT SHALL HAVE 50 mm MINIMUM COVER TO THE SIDES.
 - ALL REINFORCING BARS ARE #13 METRIC. LABELS ON EACH BAR INDICATE LENGTH. EXAMPLE: 1345 IS A #13 BAR 1345 mm LONG.
 - PANEL REINFORCEMENT BARS SHALL BE DEFORMED BILLET STEEL BARS FOR CONCRETE REINFORCEMENT CONFORMING TO THE SPECIFICATIONS OF ASTM DESIGNATION A615, GRADE 60.
 - ALL REINFORCING STEEL TO BE GALVANIZED IN ACCORDANCE WITH ASTM 767 CLASS I.
 - CONCRETE PANELS TO HAVE 28 DAY COMPRESSIVE STRENGTH OF 25,200 KPa.
 - EQUIVALENT WELDED WIRE FABRIC MAY BE USED.
 - ALL PANELS TO USE 9.5mm# CLEVIS LOOPS.
 - VSL RETAINED EARTH™ IS PROTECTED UNDER PATENT 4,725,170.
 - LIFT INSERTS ARE 6 3/4" LONG IN ALL PANELS LESS THAN 1.524M TALL. PANELS TALLER THAN 1.524M SHALL HAVE 11" LONG LIFT ANCHORS.
 - SEE FOSTER GEOTECHNICAL STD. PLANS FOR ADD'L PANEL DETAILS

DES.	DRN.	CHK.	NO.	DATE	REVISION	BY	CHK
JN	DSW	JN					

VSL CORPORATION
2840 River Place, Suite 200
Raleigh, NC 27612
Telephone: (919) 781-8272
Fax: (919) 781-4689

ALABAMA, CA, ILLINOIS, IN, MISSOURI, OH, (SEPARATE OFFICE)
MAINE, NY, SAN JOSE, CA, SPRINGFIELD, MA

WASATCH CONSTRUCTORS
FEB 28 2000
RELEASED FOR CONSTRUCTION

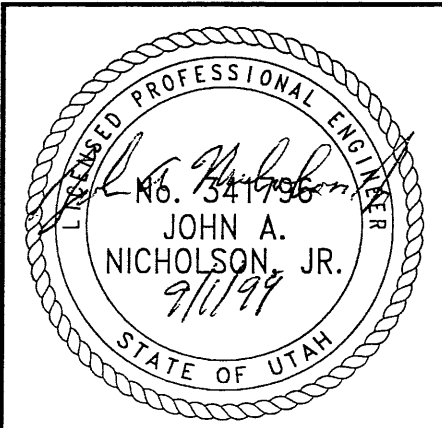

CERTIFIED FOR INTERNAL STABILITY OF RETAINED EARTH™ STRUCTURES ONLY. EXTERNAL STABILITY, INCLUDING BUT NOT LIMITED TO FOUNDATION AND SLOPE STABILITY, IS THE RESPONSIBILITY OF THE OWNER. DESIGN IS BASED ON THE ASSUMPTION THAT THE MATERIAL WITHIN THE RETAINED EARTH™ MASS, METHODS OF CONSTRUCTION, AND QUALITY OF PREFABRICATED MATERIALS CONFORM TO THE MANUFACTURER'S SPECIFICATION.

METRIC

RETAINED EARTH™ WALLS
PLAN VIEW MSE WALL "R-350-17"
UTAH I-15 INTERCHANGE
SALT LAKE COUNTY, UTAH
UTAH DEPARTMENT OF TRANSP.

DWG. NO.	3.1R-350-17.15
JOB NO.	239-0007
SHT. NO.	RE-7

RFC After Final Approval

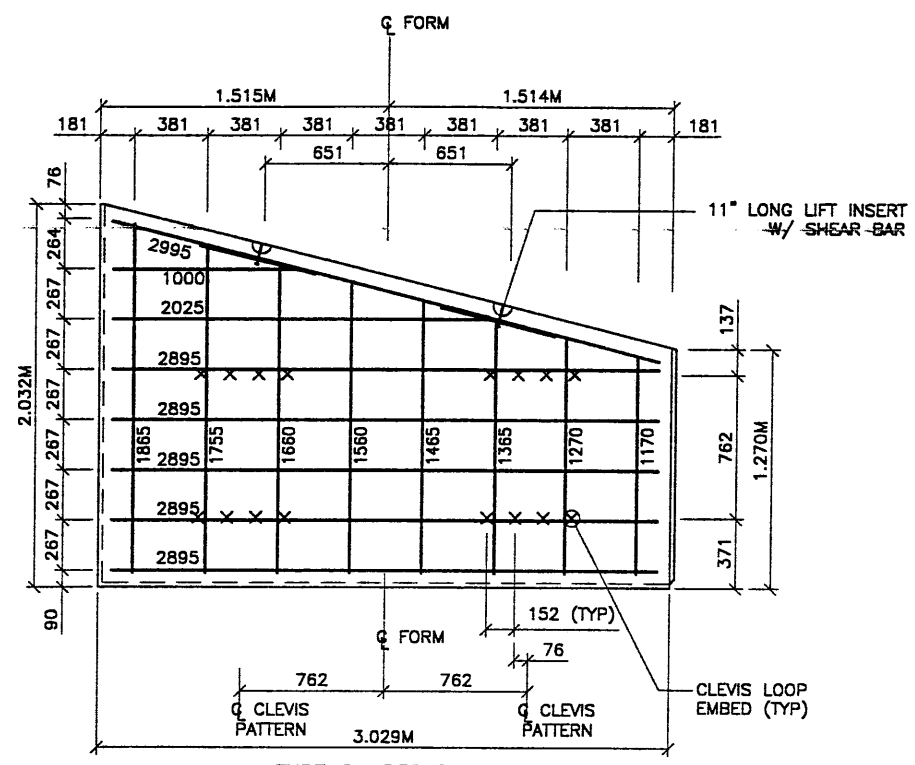

TYPE S1 REBAR
(AREA = 5.03 SQ.M)

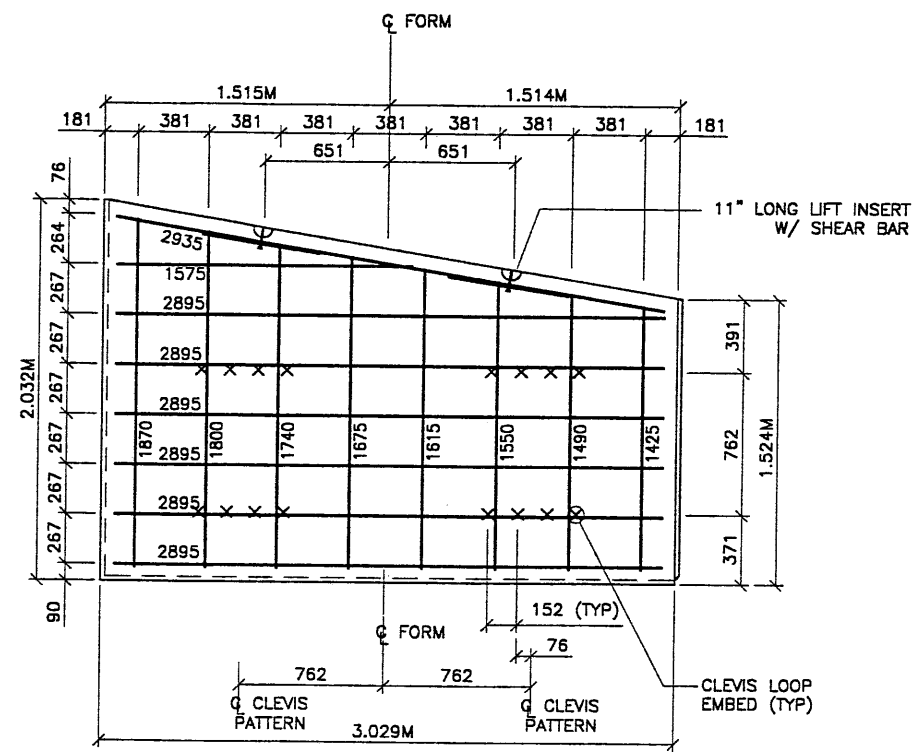

TYPE S3 REBAR
(AREA = 5.419 SQ.M)

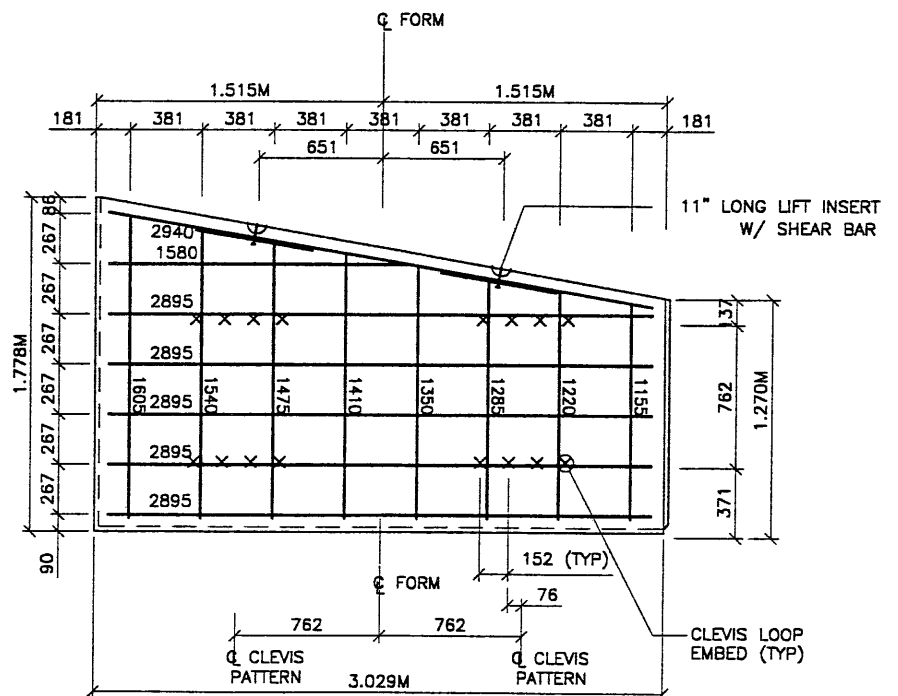

TYPE S2 REBAR
(AREA = 4.65 SQ.M)

APPROVED FOR CONSTRUCTION		
NO.	DATE	DESCRIPTION
▲	11-18-98	RELEASE FOR CONSTRUCTION

- PANEL REINFORCEMENT NOTES:**
- PANELS ARE SHOWN BACK FACE.
 - HORIZONTAL REINFORCEMENT SHALL HAVE 50 mm MINIMUM COVER TO THE BACK FACE.
 - ALL REINFORCEMENT SHALL HAVE 50 mm MINIMUM COVER TO THE SIDES.
 - ALL REINFORCING BARS ARE #13 METRIC. LABELS ON EACH BAR INDICATE LENGTH. EXAMPLE: 1345 IS A #13 BAR 1345 mm LONG.
 - PANEL REINFORCEMENT BARS SHALL BE DEFORMED BILLET STEEL BARS FOR CONCRETE REINFORCEMENT CONFORMING TO THE SPECIFICATIONS OF ASTM DESIGNATION A615, GRADE 60.
 - ALL REINFORCING STEEL TO BE GALVANIZED IN ACCORDANCE WITH ASTM 767 CLASS I.
 - CONCRETE PANELS TO HAVE 28 DAY COMPRESSIVE STRENGTH OF 25,200 KPa.
 - EQUIVALENT WELDED WIRE FABRIC MAY BE USED.
 - ALL PANELS TO USE 9.5mmØ CLEVIS LOOPS.
 - VSL RETAINED EARTH™ IS PROTECTED UNDER PATENT 4,725,170.
 - LIFT INSERTS ARE 6 3/4" LONG IN ALL PANELS LESS THAN 1.524M TALL. PANELS TALLER THAN 1.524M SHALL HAVE 11" LONG LIFT ANCHORS.
 - SEE FOSTER GEOTECHNICAL STD. PLANS FOR ADD'L PANEL DETAILS

NO.	DATE	REVISION

VSL CORPORATION
2840 Plaza Place, Suite 200
Raleigh, NC 27607
Telephone: (919) 781-6272
Fac: (919) 781-6059



ATLANTA, GA / DANIA, FL / RALEIGH, NC (CORPORATE OFFICE)
MINN. FT. / SAN JOSE, CA / SPRINGFIELD, VA

WASATCH CONSTRUCTORS
DEC 0 2 1998
RELEASED FOR CONSTRUCTION

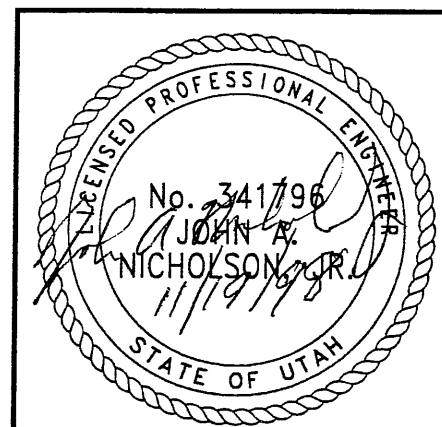

CERTIFIED FOR INTERNAL STABILITY OF RETAINED EARTH™ STRUCTURES ONLY. EXTERNAL STABILITY, INCLUDING BUT NOT LIMITED TO FOUNDATION AND SLOPE STABILITY, IS THE RESPONSIBILITY OF THE OWNER. DESIGN IS BASED ON THE ASSUMPTION THAT THE MATERIAL WITHIN THE RETAINED EARTH™ MASS, METHODS OF CONSTRUCTION, AND QUALITY OF PREFABRICATED MATERIALS CONFORM TO THE MANUFACTURER'S SPECIFICATION.

METRIC

RETAINED EARTH™ WALLS
PLAN VIEW MSE WALL "R-350-17"
UTAH I-15 INTERCHANGE
SALT LAKE COUNTY, UTAH
UTAH DEPARTMENT OF TRANSP.

DWG. NO.	2.3R-350-17.15
JOB NO.	239-0007
SHT. NO.	RE-7